

**South Central Connecticut Regional Water Authority**  
90 Sargent Drive  
New Haven, CT 06511  
or via Remote Access\*\*

**AGENDA**

**Special Meeting of Monday, May 16, 2022 at 8:30 a.m.**

---

- A. Safety Moment
  
- B. RPB Project Application – Lake Whitney Dam Improvements (Phase I) (“Application”) – Including Possible Executive Session: S. Lakshminarayanan
  - 1. Presentation and discussion regarding Application
  - 2. Consider and act on Application approval for submission to Representative Policy Board (RPB)
  - 3. Affidavit of Mr. Lakshminarayanan regarding confidential information within said Application
  - 4. Motion for Protective Order for confidential information within said Application
  - 5. Protective Order concerning confidential information within said Application for submission to the RPB
  - 6. Consider and act on proposed resolution for associated Application financing and submission to the RPB: R. Kowalski
  
- C. Adjourn

\*\* Members of the public may attend the meeting in person or via remote access. For information on attending the meeting via remote access, and to view meeting documents, please visit <https://tinyurl.com/3mp2h37x>. For questions, contact the board office at [jslubowski@rwater.com](mailto:jslubowski@rwater.com) or call 203-401-2515.

South Central Connecticut Regional Water Authority  
Special Meeting  
Monday, May 16, 2022 at 8:30 a.m.

Remote Meeting Instructions:

**Call in (*audio only*)**

[+1 469-965-2517,,554343371#](tel:+14699652517554343371) United States, Dallas

Phone Conference ID: 554 343 371#

For questions on attending the meeting, please contact the board office at 203-401-2515 or by email at [jslubowski@rwater.com](mailto:jslubowski@rwater.com)

# SAFETY MOMENT

## MAY – NATIONAL WATER SAFETY MONTH

In recognition of the popularity of swimming and other water-related recreational activities in the United States, and the resulting need for ongoing public education on safe water practices, the month of May is National Water Safety Month!!!

### Water Safety Steps:

- Educate children and adults about water safety.
- Never leave a child unattended near water in a pool, tub, bucket or ocean.
- Only swim in designated swimming areas.
- Designate a “Water Watcher” to maintain constant watch over children in the pool.
- Pools should have a fence around them at least 60” tall, with a self-closing, self-latching gate and the gate should never be propped open.
- Keep a phone at poolside so that you never have to leave the pool to answer the phone.
- Learn CPR and rescue breathing.
- Do not use flotation devices as a substitute for supervision.

Service – Teamwork – Accountability – Respect – Safety

Tap Into  
Safety

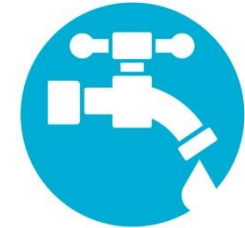

Regional Water Authority



NATIONAL  
Water Safety  
MONTH

Safety is a core company value at the Regional Water Authority .  
It is our goal to reduce workplace injuries to zero.

Regional Water Authority

**South Central Connecticut Regional Water Authority**  
90 Sargent Drive, New Haven, Connecticut 06511-5966 203-562-4020  
<http://www.rwater.com>

TO: David Borowy, Chair  
Kevin Curseaden  
Anthony DiSalvo  
Catherine LaMarr  
Suzanne Sack

FROM: Sunny Lakshminarayanan   
Vice President – Engineering and Environmental Services

DATE: May 16, 2022

SUBJECT: Application to the Representative Policy Board for Approval of the Lake Whitney Dam and Spillway Improvements Project – Phase 1 located in Hamden, CT

Attached for your review is an application to the Representative Policy Board (RPB) for approval of the Lake Whitney Dam and Spillway Improvements Project – Phase 1 located in Hamden, CT. Phase 1 will include advancement of the analysis of selected design alternatives to the point of decision of the best design alternative, and advancement thereof to final design.

Section 19 of Special Act 77-98, as amended, requires RPB approval before the Authority commences any capital project that will cost more than \$2,000,000. The proposed project will cost up to \$5.52 million and is expected to be completed during FY 2024.

This application is a two phase process. The Phase 1 application proposes to advance the analysis of selected alternatives to the point where a final decision can be made on the best design alternative to move forward. Once that decision is made, a pre-qualified group of contractors will assist the design team in completing the design of the project. The pre-qualified contractors will also assist with value engineering and cost estimating, as well as providing their individual cost proposals for the project. The initial phase of the contract may consist of a trial grout program for the existing masonry dam if an alternative that includes a grouted solution is selected. Phase 1 of the project will also include continued meetings with the community to give area residents a voice in the project planning process, to assess their concerns, and develop a roadmap to address them during the project, to the extent feasible and prudent. Phase 2 of the project will include awarding the entire project to a qualified contractor for construction. Phase 2 will be submitted in a separate application.

Also attached is a draft cover letter to the RPB and a resolution for the Authority's consideration.

Section 1-210(b)(19) of the Connecticut General Statutes provides that documents describing critical infrastructure and related operational details of water supply and distribution systems are exempt from the public disclosure. This application contains material that falls within the category of confidential protected information. This material is contained in Appendices C, E, H, and J of the Application and is enclosed in the attached specially-marked envelope for forwarding to the RPB along with an affidavit, the Motion for Protective Order and the Protective Order. I respectfully request that this material be protected from public disclosure and be discussed in executive session.

This Application will be presented to you at your May 16, 2022 meeting. If you have any questions regarding the application prior to your meeting, please contact me to discuss them.

SL/lm  
Enclosures

cc: L. Bingaman  
R. Kowalski  
L. Marcik

May 16, 2022

Members of the Representative Policy Board  
South Central Connecticut Regional Water District  
90 Sargent Drive  
New Haven, CT 06511-5966

Subject: Application to the Representative Policy Board for Approval of the Lake Whitney Dam and Spillway Improvements Project - Phase 1, Located in Hamden, CT

Ladies and Gentlemen:

The South Central Connecticut Regional Water Authority requests that the Representative Policy Board (RPB) accept the following enclosed document as complete:

Application for Approval to the Representative Policy Board of the Lake Whitney Dam and Spillway Improvements Project – Phase 1, Located in Hamden, CT

Based on our conclusion that the proposed actions are consistent with the policies and advance the goals of the South Central Connecticut Regional Water Authority, are in the best interests of our customers, and will have no significant adverse impact on the environment, we are further requesting that the RPB approve this action following a public hearing.

Section 1-210(b)(19) of the Connecticut General Statutes provides that documents describing critical infrastructure and related operational details of water supply and distribution systems are exempt from public disclosure. This application contains materials that fall within the category of confidential protected information. This material is contained in Appendices C, E, H, and J of the Application, and is attached separately herein.

To protect this material from public disclosure during Application processing, including public hearings, contemplated by Sections 10 and 19 of the Authority's enabling legislation we are requesting that the RPB take the following protective measures:

- Grant the protective order that accompanies the application.
- Conduct any part of the public hearing on this application that includes detailed discussion of the protected material in a special session closed to the public, including keeping the recording of that session confidential.

Counsel to the Authority and RPB recommends that the procedures put in place for the closed public hearing follow closely the procedures followed by the Public Utilities Regulatory Authority in similar circumstances. You should feel free to follow up regarding details of these procedures directly with counsel.

Any questions regarding this Application may be directed to Sunny Lakshminarayanan, Vice President Engineering and Environmental Services.

Sincerely,

SOUTH CENTRAL CONNECTICUT REGIONAL WATER AUTHORITY

---

David Borowy, Chair  
Kevin Curseaden  
Anthony DiSalvo  
Catherine LaMarr  
Suzanne Sack

Enclosures

SL/lm

**RESOLUTIONS FOR ADOPTION  
BY REGIONAL WATER AUTHORITY**

Authority Meeting May 16, 2022

**Resolved**, that the Authority hereby accepts the new Application, dated May 16, 2022, for a Project of the Lake Whitney Dam and Spillway Improvements Project – Phase 1 located in Hamden, Connecticut, as a completed Application, substantially in the form submitted to this meeting, and authorizes filing said Application with the Representative Policy Board (“RPB”); and

**Further Resolved**, if approved by the RPB, the President and CEO, the Vice President of Operations and Business Practices, or the Vice President of Engineering and Environmental Services, are authorized to take any and all actions necessary to complete the improvements at the Lake Whitney Dam and Spillway in Hamden, Connecticut.

---

Application for Approval to the  
Representative Policy Board: Lake  
Whitney Dam and Spillway  
Improvements Project - Phase 1

---





# **Application for Approval to the Representative Policy Board: Lake Whitney Dam and Spillway Improvements Project – Phase 1**

## **Table of Contents**

<b>1. Statement of Application</b>	<b>1</b>
Figure 1 – Map of Lake Whitney	2
<b>2. Need for the Proposed Action</b>	<b>3</b>
2.1 Need for the Dam and Spillway Improvements Project	3
<b>3. Description of the Proposed Action</b>	<b>5</b>
3.1 Description of Phase 1 of the Project	5
3.2 Alternative Project Delivery Methodology	6
<b>4. Analysis of Alternatives to the Proposed Action</b>	<b>7</b>
4.1 Alternatives to Phase 1	7
4.2 Project Approaches Considered During Design	8
4.3 Hydropower Generation Project Evaluation	8
<b>5. Estimate of the Cost to be Incurred and/or Saved</b>	<b>8</b>
5.1 Capital Cost	8
Table 1	9
5.2 Value Engineering	9
5.3 Bonds or other Obligations the Authority Intends to Issue	9
<b>6. Preliminary Project Schedule and Permitting</b>	<b>9</b>
6.1 Schedule	9
6.2 Permitting	10
<b>7. Statement of the Facts on Which the Board is Expected to Rely in Granting the Approval Sought</b>	<b>10</b>
<b>8. Explanation of Unusual Circumstances Involved in the Application</b>	<b>11</b>
<b>9. Conclusion</b>	<b>12</b>

## **Appendices**

- Appendix A: Connecticut Dam Safety Regulations
- Appendix B: Hydrology and Hydraulics Analysis Summary Report, dated April 2, 2020, prepared by GZA
- Appendix C: Subsurface Investigations and Geotechnical Analyses Summary Memorandum, dated August 7, 2020, prepared by GZA - ANNEXED
- Appendix D: CTDEEP Guidelines For Inspection And Maintenance Of Dams, 2001
- Appendix E: Proposed Conditions Design Memorandum, Lake Whitney Dam Improvements, dated April 2, 2021, prepared by GZA - ANNEXED
- Appendix F: International Water Power and Dam Construction periodical article “Life-span of Storage Dams” by Martin Wieland, dated March 3, 2010
- Appendix G: Safe Yield and Drought Resiliency Evaluation, dated May 31, 2019, prepared by Tighe & Bond
- Appendix H: 45% Design Drawings, dated April 2, 2021, prepared by GZA - ANNEXED
- Appendix I: Conceptual Project Cost Summary, dated April 8, 2022, prepared by GZA
- Appendix J: Dam Improvements Alternatives Analysis Memorandum, dated October 12, 2020, prepared by GZA- ANNEXED
- Appendix K: Lake Whitney Hydropower Assessment & Funding Memorandum, dated November 27, 2019, prepared by GZA.

## 1. Statement of Application

In accordance with Section 19 of Special Act 77-98, as amended, the South Central Connecticut Regional Water Authority (RWA) is pleased to present this approximately \$5.52 million application for the design of the Lake Whitney Dam and Spillway Improvements Project – Phase 1 (the Project) to the Representative Policy Board (RPB) for review and approval. Section 19 of Special Act 77-98, as amended, requires the RPB approval before the Authority expends more than \$2 million for any capital project.

The proposed Phase 1 project cost is a not-to-exceed amount of \$5,520,000 including approximately \$1,820,000 million spent to date on evaluations and design work. As discussed further in this application, the primary driver of the project is determining the best possible design solution for the RWA and its customers for the needed improvements to the Lake Whitney Dam. These improvements are necessary to improve dam safety, reduce risks, and to continue to reliably provide source water to the Lake Whitney Water Treatment Plant (LWWTP).

The project application originally planned included all project work necessary to improve the dam, and estimated at approximately \$20 million. Recent high-level cost estimates for the improvement alternatives under consideration range from \$38 million to \$58 million (including a 30% contingency on construction). Due to this wide range of estimates, the overall project cost will vary based on the design solution selected. Several design alternatives remain under consideration.

This Phase 1 application proposes to advance the analysis of selected alternatives to the point where a final decision can be made on the best design alternative to move forward. Once that decision is made, a pre-qualified group of contractors will assist the design team in completing the design of the project. The pre-qualified contractors will also assist with value engineering and cost estimating, as well as providing their individual cost proposals for the project. The initial phase of the contract may consist of a trial grout program for the existing masonry dam if an alternative that includes a grouted solution is selected. Phase 1 of the project will also include continued meetings with the community to give area residents a voice in the project planning process, to assess their concerns, and develop a roadmap to address them during the project, to the extent feasible and prudent.

Phase 2 of the project will include awarding the entire project to a qualified contractor for construction. Phase 2 will be submitted in a separate application.

The Lake Whitney Dam is located in the town of Hamden on the east side of Whitney Avenue, approximately 1,700 feet north of the New Haven-Hamden town line. The dam impounds Lake Whitney whose source is the Mill River. Lake Whitney meanders through the highly urbanized center of Hamden, flooding approximately 2.5 miles of the Mill River and has a watershed area of 36.4 square miles. The lake is the sole source of water to the adjacent LWWTP. See Figure 1 for a map of Lake Whitney. Lake Whitney, averaging less than one-quarter mile wide, is divided by bridge crossings into a series of four major basins. The lake has a total capacity of 527 million gallons and a useable capacity of 349 million gallons.

The Lake Whitney Dam was originally constructed in 1860-1861. The original dam was approximately 500 feet long and 39 feet at its highest point. It was constructed with a mortared stone masonry face downstream (exposed side) and a concrete face upstream (reservoir side). The inside of the dam was filled with loose rock. Plans and specifications for the construction of the original dam do not exist, a deficiency noted in the 1872 New Haven Water Company's Engineer's Report.

Figure 1 – Map of Lake Whitney

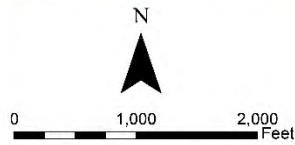
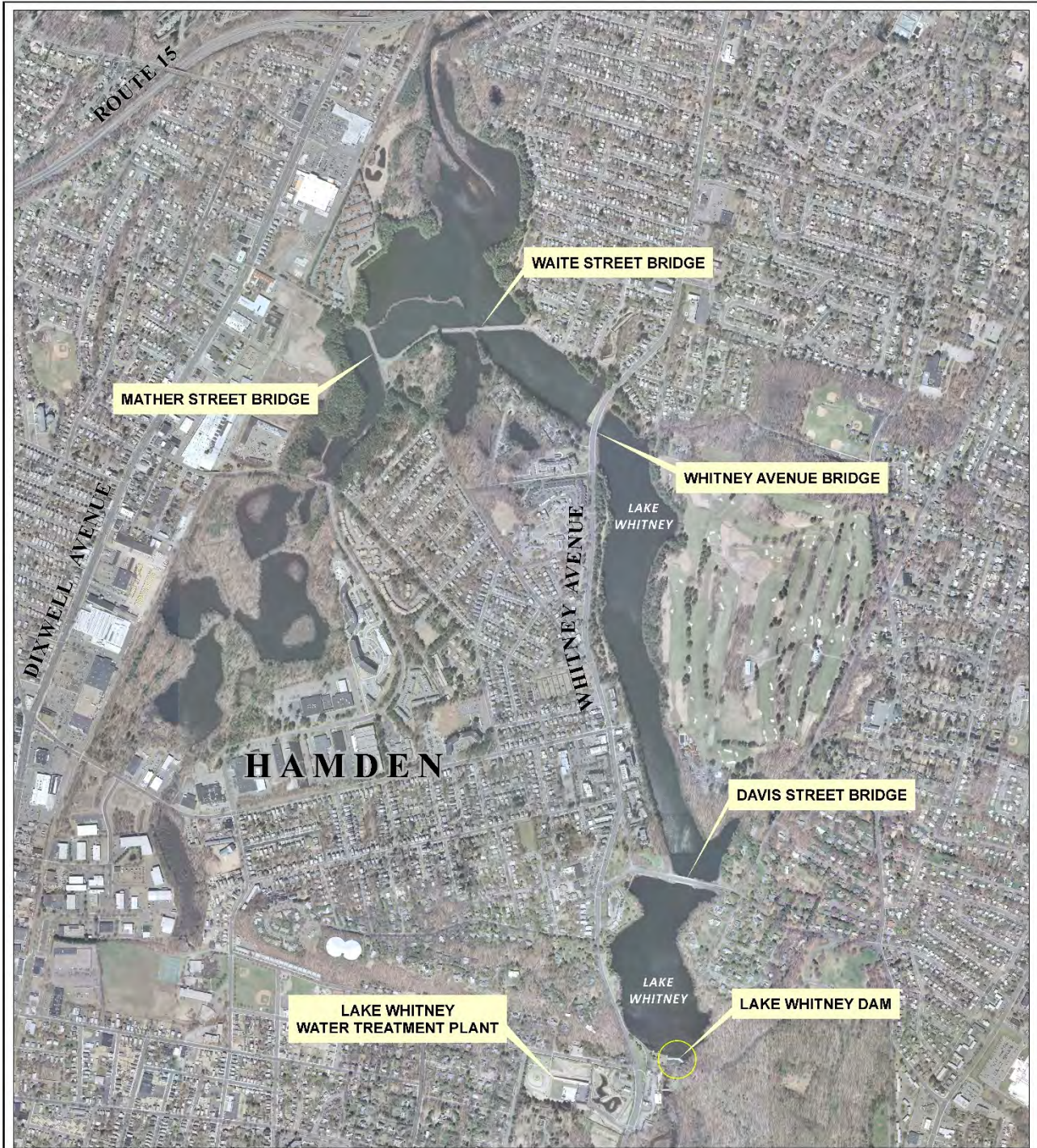

LAKE WHITNEY DAM IMPROVEMENTS PROJECT  
HAMDEN, CONNECTICUT

MAY 2022

FIGURE 1  
PROJECT AREA MAP

 Regional Water Authority  
Tapping the Possibilities™

M:\RWA GIS Mapping\Lake Whitney Dam 2021\Lake Whitney Dam Area Map4-2022rev.mxd

Soon after the dam was completed, in 1866-67, the region experienced water shortages that resulted in a decision to raise the dam by approximately 4.5 feet.

The next major dam upgrade in 1916-17, raised the dam 19 inches and lengthened the spillway 150 feet. Work completed in 1964-65 addressed dam penetrations and added gate and screen chambers. In 1982, repairs were made to the spillway's foundation after a significant rainfall event caused erosion of the foundation bedrock. In 1992, work was completed to install a drainage system on the upstream side to maintain dam stability. In 2000, minor grouting was performed on the masonry portion and a new concrete cap was installed on the top of the dam. During the construction of the LWWTP in 2003-2005, dam improvements included the installation of a raw water screen and a drain along the downstream face of the dam, and the construction of an artificial waterfall to provide spillway flow when the reservoir level is low. Today the Lake Whitney Dam is over 750 feet long and 43 feet high with a 250-foot-long spillway.

While minor dam stability improvements have been included in previous dam expansion projects, there have been no projects completed since the dam's original construction that have been solely performed to significantly improve the dam's stability.

The design team for the project includes RWA engineering, environmental, and operations staff; GZA GeoEnvironmental, Inc. (GZA), the primary design consultant; and, Tighe & Bond, Inc. (T&B), as a project advisor to RWA.

## **2. Need for the Proposed Action**

### **2.1 Need for the Dam and Spillway Improvements Project and Need for Phase 1**

The Lake Whitney Dam and Spillway Improvements Project are necessary to increase the dam's spillway capacity, enhance the stability of the dam, and to address seepage. Completing these actions will result in the dam complying with evolving regulatory requirements and recognized standards for dam safety and will ensure that the RWA mitigates the dam's susceptibility to failure to the largest extent possible. The project is also necessary to address end of useful life considerations and to safeguard Lake Whitney's function as a water supply. In addition, the proposed improvements to the dam will substantially lower the risk of dam failure from the increasing frequency of climate-change induced floods.

The Lake Whitney Dam is classified by the Connecticut Department of Energy and Environmental Protection (CTDEEP) as a Class C dam, which is a high hazard dam as defined in the Connecticut Dam Safety Regulations (Section 22a-409-1 and 2). These regulations have been included as Appendix A.

Connecticut's Dam Regulations provide the Commissioner of CTDEEP the authority to require dam owners to make repairs or improvements to a dam. Given the dam's high hazard classification, the Commissioner could require the RWA to perform the necessary repairs and improvements to the dam to bring it into compliance with the referenced Connecticut Dam Safety Regulations. CTDEEP is aware of the Lake Whitney Dam Project and has not yet ordered the RWA to make improvements. Delaying action until an order was received is not in the best interests of the public or the RWA.

An estimated 8,000 people live, attend schools, and work in the area likely to be impacted if the dam failed. Failure would very likely result in the loss of many lives, cause an enormous number of injuries, cause significant damage to facilities and infrastructure downstream of the dam, and have an adverse impact on the environment. The restoration of the area that would be impacted by a dam failure could conceivably take years and hundreds of millions of dollars.

In 2019, the RWA engaged GZA to perform hydrologic and hydraulic analyses (H&H Analysis) of the Lake Whitney watershed and dam. The report was finalized in 2020 and is included as Appendix B, *Hydrology and Hydraulics Analysis Summary Report*, dated April 2, 2020. In 2020, GZA completed a subsurface investigation and stability analysis (Stability Analysis) of the dam. This report is included as Appendix C, *Subsurface Investigations and Geotechnical Analyses Summary Memorandum*, dated August 7, 2020. As discussed in CTDEEP's 2001 *Guidelines for Inspection and Maintenance of Dams*, included as Appendix D, the CTDEEP also defines general causes of overtopping as inadequate spillway size and or spillway blockage. The result of those analyses revealed that the dam has an insufficient spillway capacity and inadequate factors of safety for stability during the maximum loading case (the probable maximum flood, PMF).

Subsequent to GZA performing the studies discussed above, the RWA retained GZA to design the necessary repairs and improvements at the Lake Whitney Dam. As discussed in GZA's *Proposed Conditions Design Memorandum* (Design Memorandum), dated April 2, 2021, included as Appendix E, GZA selected the 1,000-year flood as the flood for which spillway capacity would be designed.

In conclusion, based on GZA's H&H and Stability Analyses, the existing configuration of the dam does not meet evolving regulatory requirements or recommendations for spillway capacity and stability during the PMF, the required design flood.

The intended lifespan of the Lake Whitney Dam for which it was designed or anticipated to be is not known. According to Dr. Martin Wieland, Chairman of the Committee on Seismic Aspects of Dam Design of the International Commission on Large Dams, in his March 3, 2010, article titled *Lifespan of Storage Dams*, included as Appendix F, "Similar to other major infrastructure projects, the design lifespan of the dam body is given as a time-span varying between the concession period and typically 100 years." Design criteria for dams have changed significantly over the years since the dam was constructed, as has the methods of analyses. End of useful life concerns must be taken into account when considering design alternatives for the Lake Whitney Dam project.

The Lake Whitney Dam is a key part of the RWA's water supply system and serves the following essential purposes:

- (i) the dam impounds Lake Whitney, an ecological asset to the community and the single source of supply for the LWWTP;
- (ii) it provides drought mitigation to the RWA's water supply by providing seasonally high volumes of source water, see Appendix G, *Safe Yield and Drought Resiliency Evaluation*, prepared by Tighe & Bond; and
- (iii) it provides water quality improvements to Mill River downstream of the dam.

Numerous studies, including those of the US Environmental Protection Agency (EPA), demonstrate that climate change will have a dramatic impact in the northeast US and needs to be taken into consideration in the selected design of the project. This will protect the RWA's distribution system, the dam, and the community down stream of the dam from the significant impacts that would occur if the existing dam failed and suddenly released the water from the Lake Whitney Reservoir.

Phase 1 of this project is needed to advance the analysis of selected alternatives and further the design of the selected alternative. Determining the best possible design solution for the RWA and its customers for the needed improvements to the Lake Whitney Dam is a complex process involving detailed engineering analysis and design; field investigations to confirm the construction and condition of the existing dam; a thorough business case evaluation weighing the costs and benefits to the RWA, community, and environment; and value engineering of the construction approach and design.

As stated in Section 1, recent high-level cost estimates for the improvement alternatives under consideration range from \$38 million to \$58 million. Due to this wide range of estimates, the overall project cost will vary based on the design solution selected. Several design alternatives remain under consideration and, at the time of application submission, approximately \$1,820,000 has been expended to progress on these activities. Additional resources are needed to reach a final decision on the design alternative and extend it to final design in Phase 1.

### **3. Description of the Proposed Action**

#### **3.1 Description of Phase 1 of the Project**

The Lake Whitney Dam and Spillway Improvements Project application originally planned included all project work necessary to improve the dam, and estimated at approximately \$20 million. As noted above, current cost estimates by GZA for the alternatives under consideration range from \$38 million to \$58 million. As a result of the increases in the estimated costs, along with a currently volatile construction market and the need to explore project alternatives more fully, Management determined that a two-phase application approach is warranted.

To advance the final design stage, funds are needed for the following activities:

- i. additional stability analyses of the alternatives;
- ii. alternative selection;
- iii. completing the design;
- iv. moving forward with a modified Design-Bid-Build project delivery method;
- v. involvement of contractors; and
- vi. test grouting if needed.

This approach will provide the most efficient way of vetting alternatives and will result in a more reliable cost estimate. The Phase 1 Application is proposed to consist of the following undertakings:

- (i) Further exploring alternatives to ensure that the chosen alternative provides a dam structure that meets regulatory requirements and recognized standards for dam safety, as well as being cost effective and environmentally sensitive. Alternatives currently under consideration include:
  - a. The alternative to construct a mass concrete section upstream of the existing dam, depicted in the 45% design drawings, included as Appendix H, and described in the Design Memorandum (Appendix E).
  - b. The alternative to construct a mass concrete abutment downstream of the existing dam. The existing stone masonry face of the dam would be covered by a new concrete abutment that might be finished with a stone masonry facade.
  - c. The alternative for a new concrete dam constructed upstream, and independent of the existing dam. This alternative is the only one that structurally separates the existing dam from a new dam.
- (ii) GZA will develop the contract documents once the RWA makes a final alternative selection. This work will include the retention of a grouting consultant to assist with the specialized grouting design of the existing dam if a grouted solution is selected. Project management and design reviews by Management are also included in this project step.

- (iii) The development of a Request for Qualifications (RFQ) for contractors to assist with the modified design-bid-build project delivery method that Management believes is appropriate for this project, the selection of contractors, and contractor assistance with value engineering and detailed cost estimating.
- (iv) The development, performance, and analysis of a grouting trial program of the existing dam if an alternative employing grouting is selected as the final alternative. A successful trial would result in the development of final grouting specifications for use in the dam improvements project. A failure of the trial program would necessitate a re-examination of design alternatives. Management and GZA believe that the trial program will be successful.
- (v) Continuing relationship building efforts with the community to give the community a voice in the project planning process and to assess their concerns and develop a roadmap to address those concerns to the extent feasible and prudent.

### **3.2 Alternative Project Delivery Methodology**

The project Design Team has explored various methods of delivery that could be appropriate for this project given its large capital value and various risks that are inherent in the work. The project delivery alternatives analyzed included:

- i. Design-Bid-Build (DBB);
- ii. Early Contractor Involvement (ECI)
- iii. Design-Build;
- iv. Progressive-Design-Build;
- v. Construction Manager at Risk; and
- vi. Modified Design-Bid-Build.

The RWA's reason for evaluating project delivery alternatives is to decrease cost, increase schedule efficiency, produce the highest quality deliverable, and reduce risk.

After significant evaluation and discussion, the Design Team has recommended that the RWA consider an approach that is a modified DBB called Early Contractor Involvement (ECI). This approach brings qualified contractors into the design phase ahead of construction. The procurement of the ECI contractor starts with a request for qualifications to on-board up to three qualified firms, and then a second step to select one firm to perform construction. This procurement approach needs to be agreed upon by the EPA and the Connecticut Department of Public Health (DPH) Drinking Water State Revolving Fund (DWSRF) and they both have concurred that this procurement approach is acceptable. They have requested to be kept informed during the procurement phase of the project.

If the ECI approach is implemented, the pre-qualification process could be finished before the design is completed, and the selected ECI contractors, as part of their initial services, would be issued the drawings at the remaining design milestone levels. All the ECI contractors would be given the opportunity to provide bids on the final documents. The RWA will then evaluate the bids based upon price to perform the construction work.

The benefits of taking an ECI project delivery approach are that:

- it capitalizes on and fully utilizes the extensive design work completed to date;
- qualified contractors are involved in final design and bidding;
- it reduces the risk of potential regulatory delays;



- the final contractor selected will have better understanding of the project scope and risk;
- it provides the RWA additional confidence knowing that the cost and schedule estimates, as well as the potential risks during construction, will have been evaluated extensively prior to the start of construction;
- the resulting risk reduction should translate to cost savings and cost containment during construction;
- the ECI approach can be abandoned at any time during the process, giving the RWA the option to have the design consultant complete the design and proceed with a typical DBB approach. This provision will be included in the ECI procurement documents.

#### **4. Analysis of Alternatives to the Proposed Action**

##### **4.1 Alternatives to Phase 1**

The Lake Whitney Dam and Spillway Improvements Project – Phase 1 application is proposed to provide:

- i. funding to perform additional stability analyses of the alternatives under consideration;
- ii. alternative selection;
- iii. completion of design;
- iv. progress for the alternative project delivery method of modified DBB and the involvement of contractors; and
- v. trial grouting.

There are two alternatives to the Phase 1 application:

##### **A. Take no action**

Under this alternative no action to make improvements to the Lake Whitney Dam would be taken. As discussed in Section 2, there are safety conditions with the existing dam that need to be addressed. Not taking action to address those conditions is not in the best interests of the community or the RWA and its customers.

##### **B. Submission of an application to complete the 45% design and construct the improvements**

Conceptual cost estimates for the alternatives currently under consideration have increased substantially during the past two years. The project has a concept-level cost range for previously identified alternatives between \$38 million and \$58 million. See Appendix I, *Conceptual Project Cost Summary*, for currently estimated costs. While the concept in the current 45% design plans may be that alternative, additional work is needed to substantiate a decision to take that design further, particularly considering the concept of grouting discussed above. Moving forward at this time with the 45% design concept is not in the best interests of the RWA's the customers due to the uncertainty regarding the best course of action.

Completing the Phase 1 undertakings proposed in Section 3.1 will lead to the selection of the best alternative and provide the most reliable cost estimate for the future Phase II application.

## 4.2 Project Approaches Considered During Design

The information on alternative considerations below is provided to enhance understanding of the analyses that have been conducted. It is not intended to be an exhaustive discussion, including a business case evaluation that is presented in the Phase 2 application.

After completion of the Design Memorandum in August 2020, the Project Design Team turned their attention to consideration of alternatives. The result of that undertaking is included as Appendix J, *Dam Improvements Alternatives Analysis Memorandum* (Alternatives Analysis). The estimated costs used to compare the most viable alternatives have been updated in Appendix I.

More than 20 different alternatives were evaluated through a lens of comparative study of cost, constructability, safety, permit-ability, and impacts to the community. Of those alternatives, five were selected as the best to be compared to one another. Common to all five alternatives are an expanded side-channel spillway, non-overflow masonry and embankment toe protection, and main spillway scour protection.

## 4.3 Hydropower Generation Project Evaluation

In addition to addressing the dam safety concerns, the RWA requested that GZA perform a feasibility level evaluation of the hydropower potential at the Lake Whitney Dam. GZA evaluated two hydropower options that consisted of traditional hydropower and conduit power. The traditional hydropower option consisted of construction of a powerhouse adjacent to the existing dam outlet and construction of a turbine connected to the 42-inch diameter blow-off line. The conduit hydropower option consisted of the construction of a powerhouse near the water treatment plant and construction of a turbine within the 36-inch diameter pipeline between the Lake Whitney Dam and the LWWTP. Ultimately, incorporation of hydropower was not included as part of the Lake Whitney Dam rehabilitation because the payback period for the investment was between 50 and 100 years, depending on the alternative, and incorporation of hydropower at the dam would bring additional significant regulatory requirements and continued oversight from the Federal Energy Regulatory Commission (FERC).

Additional information regarding the hydropower evaluation is included as Appendix K, *Lake Whitney Hydropower Assessment & Funding Memorandum*, dated November 27, 2019.

## 5. Estimate of the Cost to be Incurred and/or Saved

### 5.1 Capital Cost

As shown in Table 1, the Phase 1 Design of the project will result in a capital expenditure of approximately \$5.52 million. The RWA's expenditures on the project to date are approximately \$1,820,000. This level of expenditure was necessary in order to:

- i. conduct the field investigations;
- ii. perform preliminary engineering and alternatives analyses;
- iii. develop proposed conditions design reports;
- iv. develop 45% design documents;
- v. conduct value engineering workshops; and

- vi. hold pre-permitting consultation with various regulatory agencies.

A breakdown of the estimated capital cost for this project is presented in Table 1 below.

**Table 1**  
**Estimated Project Capital Cost for Lake Whitney Dam and Spillway Improvements – Phase 1**

<b>Cost Description</b>	<b>Estimated Cost</b>
Previous Expenditures (from 2019 through April 2022) (includes design, geotech, VE review, peer review)	\$1,820,000
Completion of Final Design, VE review, and Permitting	\$700,000
RWA Project Management	\$400,000
Consultants: Public Outreach, Owner’s Rep, Grouting, etc.	\$400,000
ECl procurement including stipends	\$200,000
ECl performing grouting testing	<u>\$2,000,000</u>
<b>Total</b>	<b>\$5,520,000</b>

## 5.2 Value Engineering

In accordance with the regulations set forth in Section 22a-482-3 of the Regulations of Connecticut State Agencies (RCSA), all projects receiving State Revolving Funds and having capital costs more than \$10 million shall include a value engineering (VE) analysis and implementation. Although not required by RCSA, the RWA engaged a qualified firm, GHD, to perform the VE services as a prudent management step. The scope of the VE effort follows the industry standard phases of engagement with the VE firm, the owner (RWA), and the engineer of record (GZA).

The VE process to date has resulted in a report from GHD that contains a number of suggested ideas, some of which would create cost savings for the project, and some that would add value and also add cost to the project. The ideas have been discussed by the RWA and the designer GZA, and the RWA has responded to GHD with suggestions as to which VE ideas should be further defined and quantified in terms of cost, and which should be dropped due to conflicts with the goals for the project. Value Engineering efforts will continue throughout Phase 1.

## 5.3 Bonds or Other Obligations the Authority Intends to Issue

The annual cost of this phase of the project to an average residential customer, assuming a conservative financing assumption of RWA Bonds, would be approximately \$1.81 based on a cost of \$5.52 million. However, we expect this project to be funded by a combination of funding sources. The RWA is pursuing funding under the CTDPH DWSRF as well as financing under the WIFIA administered by the EPA. By utilizing these funding sources, the total financing costs associated with this project are expected to be lower than RWA-issued bonds. Internally generated funds may also be used.

Initial financing coordination meetings with representation from RWA, DPH, and WIFIA took place in February 2022 and coordination meetings are expected to continue. DWSRF and/or WIFIA financing may be used as reimbursement or potentially as Phase 1 progresses.

## 6. Preliminary Project Schedule and Permitting

### 6.1 Schedule

The project schedule presented below includes anticipated state and federal approval durations based on discussions with regulators:

1. Phase 1 RPB Application	May 2022
2. Design	July 2022 to September 2023
3. Permitting to perform grout panel (if needed)	January 2023 to May 2023
4. Qualify and Award ECI Contract	June 2022 to August 2022
5. Perform grout panel (if needed)	June 2023 to September 2023
6. Phase 2 RPB Application	Plan to submit November 2023
7. Estimated permitting / construction of dam improvements	June 2023 to July 2026

## 6.2 Permitting

During the advancement of the design, the Project Design Team coordinated numerous pre-permitting meetings with state and federal regulators to discuss potential permitting implications for the project.

The pre-permitting meetings have included:

- two meetings with CTDEEP Dam Safety;
- three meetings with CTDEEP Fisheries;
- two meetings with CTDEEP Water Quality;
- meeting with Army Corps of Engineers; and
- two meetings with State Historical Preservation Office (SHPO).

The following major permits are anticipated to be required for Phase 1 of the work:

- Army Corps of Engineers;
- CT DEEP Dam Safety;
- CT DEEP Fisheries; and
- US Fish and Wildlife Review.

In addition, the Project is anticipated to be subject to review and approval from the following:

- CT Department of Public Health;
- EPA in support of WIFIA funding;
- Tribal Historic Preservation Office Notification;
- SHPO; and
- Natural Diversity Data Base Review.

## 7. Statement of the Facts on Which the Board is Expected to Rely in Granting the Approval Sought

- The Lake Whitney Dam was originally constructed in 1860 and although it has been improved and expanded on several occasions, there have been no significant structural enhancements to the dam since its construction.
- The Connecticut Department of Energy and Environmental Protection (CTDEEP) Dam Safety provides regulatory oversight of the RWA's dams.
- The Lake Whitney Dam is a Class C high hazard dam as defined in the Connecticut Dam Safety Regulations.

- Failure of the Lake Whitney Dam would result in long-term destruction downstream of the dam and probable loss of life.
- The Lake Whitney Dam does not have sufficient hydraulic capacity to pass the Probable Maximum Flood (PMF), the present-day design flood.
- Stability analyses of the current configuration of the dam show that the dam does not meet regulatory requirements and recognized standards for dam safety during the PMF.
- The Lake Whitney Dam does not have provisions to mitigate external erosion and downstream scour that would likely occur and potentially result in the failure of the dam due to overtopping during the PMF. Scour is an engineering term for the erosion of soil underwater, usually concerning sub-water structures.
- The Lake Whitney Dam impounds a major source of water in the RWA's reservoir system and loss of service of Lake Whitney would reduce the adequacy of the RWA's water supply.
- The Lake Whitney Dam must be improved or replaced.
- The RWA has reviewed numerous improvement alternatives and cost mitigation measures related to the Lake Whitney Dam.
- Recent conceptual level cost estimates have increased significantly and have caused the RWA to consider additional alternatives to ensure that the most cost effective and prudent alternative is selected as the final solution.
- Approximately \$5.52 million in funds (including monies spent to date) are needed for:
  - additional stability analyses of the alternatives;
  - alternative design review and selection;
  - completing the design;
  - moving forward with the alternative project delivery method of modified Design-Bid-Build and the involvement of contractors; and
  - potential testing of grouting.
- Given the scope of the project and its historic significance, the RWA will engage the community to ensure that their concerns are heard.

## **8. Explanation of Unusual Circumstances Involved in the Application**

The costs of construction have risen appreciably over the past two years mostly due to significant increases in materials and materials handling costs, and the current inflationary market will continue to drive prices up in the short-term. Additional consideration of alternatives is therefore vital and the project is currently approaching \$2 million in capital expenditures.

The Lake Whitney Dam exhibits a higher risk than many other capital projects and necessitates a significant investigative effort. The design effort to obtain a 45% level design, when compared to more common RWA projects, requires more work in the form of geotechnical borings and sampling than a standard project would,

due to the type and scale of work. A significant amount of this investigative work has already been completed to better define design assumptions and to better estimate the cost that will be incurred during the construction phase.

Alternative Project Delivery methods were considered for this project in order to select a contractor that is qualified to perform this work. The project team feels this modified approach will result in the greatest reduction in construction risk, optimized cost, and strongest design outcome for the delivery of the project.

## **9. Conclusion**

The Lake Whitney Dam is a 160-year-old historic structure that has not had significant structural or stability improvements since its construction. The dam is an integral part of the RWA's water supply system and the single source to RWA's Lake Whitney Water Treatment Plant. The dam does not meet evolving regulatory requirements and recognized standards for dam stability during the PMF design storm and it must therefore be improved or replaced.

The proposed Phase 1 project will provide:

- i. funding needed for the consideration of additional construction alternatives;
- ii. the selection of a final alternative;
- iii. the completion of contract documents;
- iv. the engagement of dam contractors for design and estimating assistance; and
- v. for performing a potential trial grout program on the existing masonry dam.

These results-focused efforts will provide the way forward to the best possible design solution with a high degree of confidence of costs and serve in the best interests of the RWA and its customers.

# **Appendix A**

## **Connecticut Dam Safety Regulations**





*Regulations of Connecticut State Agencies*

TITLE 22a. Environmental Protection

---

---

*Agency*

**Department of Energy and Environmental Protection**

*Subject*

**Dams and Similar Structures**

*Inclusive Sections*

**§§ 22a-409-1—22a-409-2**

CONTENTS

---

- Sec. 22a-409-1. Definitions. Registration of dams and similar structures.  
Sec. 22a-409-2. Dam safety inspection and classification

**Dams and Similar Structures**

**Sec. 22a-409-1. Definitions. Registration of dams and similar structures.**

**(a) Definitions.**

As used in Sections 22a-409-1 and 22a-409-2 of the Regulations of Connecticut State Agencies:

- (1) “Abutment” means natural ground that borders on either end of the dam structure.
- (2) “Acre-foot” means a unit of volume of water equal to 43,560 cubic feet or 325,853 gallons (one foot depth over one acre).
- (3) “Appurtenance” means any structure or mechanism other than the dam itself which is associated with its operation.
- (4) “Arterial roadway” means a roadway that provides a high level of mobility and that is frequently the route of choice for buses and trucks, as provided in the U.S. Department of Transportation document entitled “Highway Functional Classification Concepts, Criteria and Procedures, 2013 edition”.
- (5) “Breach” means an alteration of a dam either deliberately or accidentally in such a way as to release its impounded waters resulting in partial or total failure of the dam.
- (6) “Collector roadway” means a roadway that collects traffic from local roadways and connects traffic to arterial roadways, as provided in the U.S. Department of Transportation document entitled “Highway Functional Classification Concepts, Criteria and Procedures, 2013 edition”.
- (7) “Commissioner” means the Commissioner of Energy and Environmental Protection, or such commissioner’s designated representative.
- (8) “Certificate of Dam Registration” or “(CDR)” means a form issued by the commissioner to the owner that acknowledges receipt of all required information regarding a dam registration and a one-time payment of the registration fee.
- (9) “CT Dam ID Number” means a unique identifying number assigned to a dam registered and regulated by the State of Connecticut.
- (10) “Dam” means any barrier of any kind whatsoever which is capable of impounding or controlling the flow of water, including but not limited to storm water retention or detention dams, flood control structures, dikes and incompletely breached dams.
- (11) “Dam failure” has the same meaning as provided in section 22a-411a-1 of the Regulations of Connecticut State Agencies (RCSA).
- (12) “Dam height” means the vertical distance from the crest of a dam or similar structure to the downstream toe of such dam or similar structure.
- (13) “Embankment” means the fill material, usually earth or rock, placed with sloping sides providing a barrier which impounds water.
- (14) “Flood” means any high flow, overflow, or inundation by water which causes or threatens damage to persons or property.
- (15) “Hazard potential” means probable damage that would occur if the structure failed, in terms of loss of human life and economic loss or environmental damage.
- (16) “Local roadway” means a roadway that provides a high level of accessibility used

*Regulations of Connecticut State Agencies*

TITLE 22a. Environmental Protection

§22a-409-1

*Department of Energy and Environmental Protection*

to provide direct access to multiple properties, as provided in the U.S. Department of Transportation document entitled “Highway Functional Classification Concepts, Criteria and Procedures, 2013 edition”.

(17) “Operator” means the person(s) in control of, or having responsibility for, the daily operation of the dam as designated by the owner on the dam registration form required by subsection (b) of this section.

(18) “Owner” means the person(s) having legal ownership of the dam.

(19) “Person” has the same meaning as provided in section 22a-2(b) of the Connecticut General Statutes.

(20) “Professional engineer” means an individual who is currently licensed and registered under section 20-302 of the Connecticut General Statutes.

(21) “Regulated dam” means a dam subject to the jurisdiction of the Department of Energy and Environmental Protection pursuant to section 22a-401 of the Connecticut General Statutes.

(22) “Regulatory inspection” means an inspection required in accordance with section 22a-409(c) of the Connecticut General Statutes and section 22a-409-2(c) of the Regulations of Connecticut State Agencies.

(23) “Spillway design flood” or “SDF” means the largest flood that a given structure is designed to pass safely.

(24) “Structure” means the dam, its appurtenances, abutments and foundation.

(25) “Toe” means the base portion of the impounding structure which intersects with natural ground at the upstream and downstream sides.

(26) “100-year flood” means a statistical designation that there is a 1 in 100 chance that a flood of this intensity will occur at a particular geographical location during any year.

(b) **Registration.** The owner of any dam or similar structure required to be registered by section 22a-409(b) of the Connecticut General Statutes and that is not already registered shall register any such dam or similar structure with the commissioner on or before October 1, 2015. All registrations shall be submitted on a form prescribed by the commissioner and shall provide the following:

(1) The name, address, telephone number, and email address of the dam owner and operator;

(2) The name of the dam and impoundment and the CT Dam ID Number, if known;

(3) The street address of the dam location or the street address nearest to the dam location;

(4) The parcel ID number of the property where the dam is located, i.e. map, block, and lot number, or as otherwise designated by the town;

(5) The present condition of the dam;

(6) Whether there is a low-level outlet, and whether the low-level outlet is operable;

(7) A map showing the location of the dam in context to surrounding streets;

(8) A description of the materials used in constructing the dam;

(9) The dimensions of the impoundment;

*Regulations of Connecticut State Agencies*

TITLE 22a. Environmental Protection

---

---

*Department of Energy and Environmental Protection*

*§22a-409-2*

(10) The dimensions of the spillway;  
(11) A statement of the use(s) of the impounded water;  
(12) A check or money order payable to the DEEP Dam Safety Program for the amount of the registration fee required in accordance with section 22a-409(b) of the General Statutes; and

(13) Any other relevant information which the commissioner deems necessary.

(c) **Changes in registration information.** The owner shall report any change in the following information provided in the registration to the commissioner not later than ten (10) days from the date of such change:

(1) The name, address, telephone number, and email address of the dam owner or operator; and

(2) The name of the dam or its impoundment.

(d) **Certificate of Dam Registration (CDR).** Upon review of a complete registration, the commissioner shall issue a Certificate of Dam Registration (CDR) to the owner of the dam. A registration form shall not be deemed complete by the commissioner until all information specifically required by statute or regulation is submitted with the appropriate fee.

(e) **Fees.**

(1) The commissioner shall waive the registration fee for any dam which is owned by the State of Connecticut.

(2) Wherever an impoundment is formed by two or more dams, there shall be a single registration fee based on the highest dam forming the impoundment.

(3) Wherever a dam is owned by two or more owners there shall be a single registration fee.

(f) **Forfeiture and Injunction.** Failure to register a dam not previously registered, by October 1, 2015 shall subject the owner of the dam to the forfeiture and injunction provisions of section 22a-407 of the Connecticut General Statutes, as amended.

(g) **Violations.** Any violation of these regulations shall subject the owner of the dam to the injunction provisions of section 22a-6(3) of the Connecticut General Statutes, as amended, or an administrative civil penalty pursuant to sections 22a-6b-1 to 22a-6b-15 of the Regulations of Connecticut State Agencies or both.

(Effective June 23, 1986; Amended February 3, 2016)

**Sec. 22a-409-2. Dam safety inspection and classification**

(a) **Classification of Dams.**

(1) The commissioner shall assign each dam to one of five classes according to the potential impacts of a dam failure. The factors used to evaluate and assign a hazard potential are the physical characteristics of the dam, such as the dam height and capacity of the impoundment, the location of the dam, the areas impacted by a failure of the dam, and potential damage to property, infrastructure, or threat to human life as described below:

(A) A Class AA dam is a negligible hazard potential dam which, if it were to fail, would

*Regulations of Connecticut State Agencies*

TITLE 22a. Environmental Protection

§22a-409-2

*Department of Energy and Environmental Protection*

result in the following:

- (i) no measurable damage to roadways;
- (ii) no measurable damage to land and structures; and
- (iii) negligible economic loss.

(B) A Class A dam is a low hazard potential dam which, if it were to fail, would result in any of the following:

- (i) damage to agricultural land;
- (ii) damage to unpaved local roadways; or
- (iii) minimal economic loss.

(C) A Class BB dam is a moderate hazard potential dam which, if it were to fail, would result in any of the following:

- (i) damage to normally unoccupied storage structures;
- (ii) damage to paved local roadways; or
- (iii) moderate economic loss.

(D) A Class B dam is a significant hazard potential dam which, if it were to fail, would result in any of the following:

- (i) possible loss of life;
- (ii) minor damage to habitable structures, residences, including, but not limited to, industrial or commercial buildings, hospitals, convalescent homes, or schools;
- (iii) damage to local utility facilities including water supply, sewage treatment plants, fuel storage facilities, power plants, cable or telephone infrastructure, causing localized interruption of these services;

- (iv) damage to collector roadways and railroads; or
- (v) significant economic loss.

(E) A Class C dam is a high hazard potential dam which, if it were to fail, would result in any of the following:

- (i) probable loss of life;
- (ii) major damage to habitable structures, residences, including, but not limited to, industrial or commercial buildings, hospitals, convalescent homes, or schools;
- (iii) damage to major utility facilities, including public water supply, sewage treatment plants, fuel storage facilities, power plants, or electrical substations causing widespread interruption of these services;

- (iv) damage to arterial roadways; or
- (v) Great economic loss.

(2) The classification of a Class A, BB, B, and C dam shall be reviewed during each regulatory inspection.

(3) Dams shall be subject to reclassification at any time the commissioner determines that the hazard potential of the dam has changed.

(4) The dam owner may submit a request to change the hazard classification assigned to the owner's dam based on an analysis submitted to the commissioner that supports the reclassification. Recommendations made by the owner to reclassify the owner's dam shall

*Regulations of Connecticut State Agencies*

TITLE 22a. Environmental Protection

---

*Department of Energy and Environmental Protection*

§22a-409-2

be subject to review and approval by the commissioner.

(5) Where a dam is so located that its failure would likely cause a downstream dam to fail, the hazard classification of such dam shall be at least as great as that of the downstream dam.

(6) Potential damage to habitable structures shall be considered minor when habitable structures are not within the direct path of the probable flood wave produced upon failure of a dam and when such structures will experience the lower of the following elevations:

(A) No more than 1.5 feet of rise of flood water above the lowest ground elevation adjacent to the outside foundation walls; or

(B) No more than 1.5 feet of rise of flood water above the lowest habitable floor elevation of the structure.

(b) **Regulatory Inspections - Applicability.** The owner of a dam classified by the commissioner as Class C, B, BB, or A in accordance with subsection (a) of this section shall ensure a regulatory inspection is conducted for such dam in accordance with the requirements of this section except dams owned or regulated by the United States or its instrumentalities that are visually inspected on a regular basis in accordance with applicable federal requirements to the satisfaction of the commissioner:

(1) If the commissioner determines that a dam classified as AA poses a unique hazard, the commissioner may require its owner to conduct a regulatory inspection in accordance with this section except dams owned or regulated by the United States or its instrumentalities that are visually inspected on a regular basis in accordance with applicable federal requirements to the satisfaction of the commissioner.

(2) The state and each political subdivision of the state shall conduct a regulatory inspection of each dam owned by the state or such political subdivision, respectively

(c) **Regulatory Inspection Procedures.** All regulatory inspections shall be conducted by a professional engineer and use a standard dam inspection form and instructions that direct the proper use of the form. Both the inspection form and the instructions shall be developed by the commissioner and based upon accepted standards of visual dam inspection.

(1) Each regulatory inspection shall consist of, but not be limited to, the following:

(A) Visual inspection of the dam, its appurtenances, abutments, downstream toe and all other areas which could affect the safety of the dam. In addition, inspection and operation of mechanical systems, and inspection of the abutments downstream, the components of the dam which are under water during normal operation, or the interior of outlet conduits shall be made if deemed necessary by a professional engineer to more completely assess the condition of the dam;

(B) Review of all available file data related to the design, construction, post construction investigations, operation, maintenance and performance of the structure. This review shall supplement the visual inspection and aid in determining if additional analysis is required;

(C) Observation of the nature and extent of downstream development which would be subject to inundation in the event of a dam breach for purposes of assessing the potential

*Regulations of Connecticut State Agencies*

TITLE 22a. Environmental Protection

§22a-409-2

*Department of Energy and Environmental Protection*

hazard which the dam poses;

(D) Evaluation of the operation, maintenance and inspection procedures employed by the owner; and

(E) Evaluation of any other conditions which constitute or could constitute a hazard to the integrity of the structure.

(2) The professional engineer shall prepare a written report using a form prescribed by the commissioner detailing the findings of the regulatory inspection which shall include, but not be limited to, the following:

(A) An assessment of the condition of the structure based on the visual observations, available file data related to the design, construction, post construction investigations, operation, maintenance and performance of the dam, and

(B) Recommendations, if any are required as a result of the inspection and assessment, for:

(i) emergency measures or actions, if required to assure the immediate safety of the structure;

(ii) remedial measures and actions related to design, construction, operation, maintenance and inspection of the structure ;

(iii) additional detailed studies, investigations and analyses;

(iv) time periods appropriate for implementing the actions recommended in accordance with clauses (i), (ii), and (iii) of this subparagraph;

(v) routine maintenance and inspection by the owner,

(vi) a hydrologic and hydraulic analysis based on file data, visual observations, or information provided by the owner that indicates the capacity of the spillway is insufficient to safely pass the spillway design flood, or, at a minimum, the 100-year flood, if required; and

(vii) a stability analysis based on file data, visual observations, or information provided by the owner that indicates the stability of the dam may be structurally unsound under normal or extreme loading conditions.

(3) The owner shall furnish a copy of the written report to the commissioner not later than 30 days from the date he or she receives the report, but no later than March 15th of the year following the year the owner received the notification letter sent by the commissioner in accordance with section 22a-409(c) of the Connecticut General Statutes.

(A) Not later than thirty (30) days of receipt of a written request from the commissioner to perform recommended maintenance or repairs on the dam, the owner shall inform the commissioner in writing of the owner's schedule of implementation of any required recommendations. The commissioner's recommendations shall be based on the commissioner's review of the submitted inspection report and recommendations made by the owner's professional engineer contained in the report; and

(B) A copy of the report shall be kept on file with the records of the commissioner pertaining to dam safety.

(d) **Inspection Schedule.**

Regulations of Connecticut State Agencies

TITLE 22a. Environmental Protection

Department of Energy and Environmental Protection

§22a-409-2

A dam owner shall ensure a regulatory inspection is conducted as required by subsection (b) of this section according to the following inspection schedule:

<i>Hazard Class</i>	<i>Inspection Schedule</i>
Class A (low)	every 10 years
Class BB (moderate)	every 7 years
Class B (significant)	every 5 years
Class C (high)	every 2 years

**(e) Fees for Inspection by the State.**

(1) In the event the commissioner conducts a regulatory inspection of an owner's dam because such owner failed to do so, as required by subsection (b) of this section, such owner shall pay an inspection fee to cover the cost to the state for conducting the regulatory inspection. Any invoice for such fee shall be paid in accordance with the instructions on the invoice.

(2) The fee for each regulatory inspection made by the State of an owner's dam shall be \$3000.00.

(3) The commissioner shall waive the regulatory inspection fee for any dam which is owned by the State of Connecticut.

**(f) Responsibility of the Owner.**

(1) The requirement to ensure a regulatory inspection is conducted by a professional engineer does not relieve an owner of a dam of other legal duties, obligations or liabilities incidental to the ownership or operation of a dam.

(2) In addition to the regulatory inspections required by this section, the owner or operator shall inspect the dam on a regular basis to assure that no unsafe conditions are developing including, but not limited to, weather related damage, animal activity or vandalism. Class B and Class C dams shall be inspected by the owner or operator at least quarterly. Class BB dams shall be inspected by the owner or operator at least annually. Class A dams shall be inspected by the owner or operator at least every two years. A written record of said inspections shall be maintained by the owner or operator and be made available to the commissioner upon request.

(3) The owner or operator shall inspect the dam during and after the occurrence of major flood events to assure that the structure is withstanding the flood waters safely.

(4) The owner or operator shall fully and promptly advise the commissioner of any sudden or unpredicted floods, unusual circumstances or major changes in the condition of the dam.

(5) The owner or operator shall report to the commissioner any major damage which the dam has suffered, such as, overtopping by flood waters, erosion of the spillway discharge channel and any major problems which are observed to have developed, such as, new seepage or a significant increase in seepage quantities, settling, cracking or movement of the embankment or any component of the dam.

(6) To facilitate visual inspection during the intervals between regulatory inspections,



*Regulations of Connecticut State Agencies*

TITLE 22a. Environmental Protection

§22a-409-2

*Department of Energy and Environmental Protection*

the dam owner shall be required to maintain the structure and adjacent area free of brush and tree growth.

(A) Brush and tree growth shall be cleared from embankments and within twenty-five (25) feet of the upstream and downstream toe and the abutment embankment contact; and

(B) Grass on earthen embankment dams shall be established and maintained.

(7) The owner shall maintain a written record of all inspections and maintenance work performed. This record shall include observations made regarding areas of concern on the structure and descriptions of the major and minor repairs performed and materials utilized.

**(g) Inspection by the Commissioner.**

(1) The commissioner may enter upon private property at any time to investigate or inspect any dam for any reason, including, but not limited to, the following: the auditing of regulatory inspection reports, failure of the owner to conduct a regulatory inspection, to investigate a complaint, or as determined necessary after a flood event.

(2) Any inspection conducted by the commissioner in accordance with this subsection, including a regulatory inspection, shall be performed by a professional engineer or personnel of the DEEP Dam Safety Program with technical training in the inspection of dams and under the supervision of a professional engineer.

(Effective April 30, 1987; Amended February 3, 2016)



## **Appendix B**

**Hydrology and Hydraulics Analysis Summary Report, dated April 2,  
2020, prepared by GZA**





Proactive by Design



Engineering Report

# HYDROLOGY AND HYDRAULICS ANALYSIS SUMMARY REPORT LAKE WHITNEY DAM Hamden/New Haven, CT

April 2, 2020

File No. 01.00174182.00



**PREPARED FOR:**

South Central Connecticut Regional Water Authority

**PREPARED BY:**

**GZA GeoEnvironmental, Inc.**

249 Vanderbilt Avenue | Norwood, MA 02062

800-789-5848

31 Offices Nationwide

[www.gza.com](http://www.gza.com)

Copyright© 2020 GZA GeoEnvironmental, Inc.



Known for excellence.  
Built on trust.

GEOTECHNICAL  
ENVIRONMENTAL  
ECOLOGICAL  
WATER  
CONSTRUCTION  
MANAGEMENT

249 Vanderbilt Avenue  
Norwood, MA 02062  
T: 781.278.3700  
F: 781.278.5701  
F: 781.278.5702  
www.gza.com

April 2, 2020  
File No. 01.0174183.00

Mr. Orville Kelly, Capital Construction Lead  
South Central Connecticut Regional Water Authority  
90 Sargent Drive  
New Haven, Connecticut 06511

Re: Hydrology and Hydraulics Analysis Summary Report (DRAFT)  
Lake Whitney Dam Improvements Projects  
Project #107112-066506  
Hamden, Connecticut

Dear Mr. Kelly,

GZA GeoEnvironmental, Inc. (GZA) is pleased to present to the South Central Connecticut Regional Water Authority ("Authority" or "RWA") the enclosed Engineering Report for existing conditions Hydrologic and Hydraulic Analysis and Dam Breach Inundation Modeling for the Lake Whitney Dam located in Hamden, CT. The report was prepared in accordance with the Agreement for Professional Services Accepted on April 1, 2019, Appendix 1 - Scope of Work. Our report is subject to the Limitations contained in **Appendix A**.

All the results in this report including the maps in **Appendices F** and **Appendix G** are based on the Lake Whitney Dam's existing geometry. Results of the hydraulic analysis for proposed design alternatives are included within the Design Basis Report, which will be attached as **Appendix H** upon completion.

GZA appreciates the opportunity to continue to provide dam engineering services to the Authority. Please contact the undersigned if you have any questions or concerns.

Very truly yours,

GZA GEOENVIRONMENTAL, INC.

Media Sehatzadeh  
Assistant Project Manager

Todd Monson, P.E.  
Senior Project Manager

Matthew A. Taylor, P.E.  
Principal-In-Charge

David M. Leone, P.E., CFM  
Consultant/Reviewer

Attachments:  
Hydrology and Hydraulics Analysis Summary Report – Lake Whitney Dam



**TABLE OF CONTENTS**

1.0	EXECUTIVE SUMMARY .....	1
2.0	INTRODUCTION .....	2
3.0	SITE DESCRIPTION .....	2
4.0	METHODOLOGY .....	3
4.1	HYDROLOGICAL MODELING .....	4
4.2	HYDRAULIC MODELING .....	5
5.0	HYDROLOGICAL ANALYSIS .....	7
5.1	CONTRIBUTING DRAINAGE AREA .....	7
5.2	PRECIPITATION DATA .....	8
5.3	STREAMFLOW DATA .....	10
5.4	CALIBRATION AND VERIFICATION .....	10
5.4.1	CANDIDATE STORMS .....	11
5.4.2	RESULTS .....	12
5.5	PMP .....	14
5.6	PMF .....	14
5.7	ROUTING .....	15
6.0	INCREMENTAL CONSEQUENCE ANALYSIS (ICA) .....	15
6.1	MODEL EXTENTS .....	16
6.2	INITIAL AND BOUNDARY CONDITIONS .....	17
6.3	ASSUMED DAM BREACH PARAMETERS .....	17
6.4	RESULTS .....	17



**TABLE OF CONTENTS**

**TABLES**

Table 1.	Overview of Lake Whitney Dam, Reservoir and Catchment.....	3
Table 2.	Structures at Lake Whitney Dam .....	3
Table 3.	Flood Frequency Analysis, results at the gauging station on Mill River .....	10
Table 4.	Overview of historical storms used for calibration and verification at USGS 01196620.....	11
Table 5.	Summary of calibration results .....	13
Table 6.	Summary of verification results .....	13
Table 7.	Parameters based on calibration and verification.....	14
Table 8.	HMR 51/52 Derived PMP Depths for PMF Model Elements .....	14
Table 9.	Results for PMF routing compared to previous studies .....	15
Table 10.	Manning’s n Values for Different Land Uses.....	16
Table 11.	Hypothetical flood scenarios for Incremental Consequence Analysis (ICA).....	17
Table 12.	Wet Weather Dam Break Input Parameters Summary .....	17
Table 13.	Summary of ICA Results .....	18

**FIGURES**

Figure 1.	Lake Whitney Dam’s sub-catchment delineations .....	8
Figure 2.	Stations with precipitation Data available from NOAA's National Centers for Environmental Information (NCEI) .....	9
Figure 3.	Rainfall totals across Southern New England from June 4-7, 1982 (weather.gov) Lake Whitney’s catchment marked on the map .....	12
Figure 4.	Results from PMF simulation in HEC-HMS.....	15

**APPENDICES**

APPENDIX A	LIMITATIONS
APPENDIX B	KEY TERMS
APPENDIX C	HEC-HMS Calibration and verification
APPENDIX D	PMF Hydrograph
APPENDIX E	HEC-RAS Model Extents
APPENDIX F	HEC-RAS OUTPUT SUMMARIES
APPENDIX G	INUNDATION MAPS





## 1.0 EXECUTIVE SUMMARY

GZA GeoEnvironmental, Inc. (GZA) performed an existing condition hydrological & hydraulic (H&H) analysis of the catchment area draining to Lake Whitney and the hydraulic capacity of the Lake Whitney Dam to convey flood flows utilizing state of practice procedures and guidance. The purposes of the analysis are to 1) evaluate and define the Spillway Design Flood (SDF), 2) evaluate the dam's existing capacity to convey flood flows, including the SDF, and 3) develop alternatives to bring the dam into compliance with current state regulatory requirements for Class C - High hazard dams. The work was performed by GZA for South Central Connecticut Regional Water ("Authority" or "RWA") pursuant to the Agreement for Professional Services Accepted on April 1st, 2019, Appendix 1 - Scope of Work. This report is subject to the Limitations in **Appendix A**.

The dam is regulated by Connecticut Dam Safety Program administered by the Connecticut Office of Energy and Environmental Protection (CTDEEP). The Connecticut Dam Safety Program administered by CTDEEP does not provide specific guidance on defining the Spillway Design Flood (SDF) for regulatory dams. As a result, it has been GZA's experience in analyzing and designing water supply and stone masonry dams in Connecticut to use a risk-based analysis approach as outlined in *Chapter 2: Selecting and Accommodating Inflow Design Floods for Dams*, of the *FERC Engineering Guidelines for the Evaluation of Hydropower Projects* as well as documented in FEMA Selecting and Accommodating Inflow Design Floods for Dams FEMA P-94. . As part of this evaluation, GZA completed the following tasks:

1. Review the previous analyses and available information
2. Update the previous Probable Maximum Flood Study
3. Perform an Incremental Consequence Analysis (ICA) / Assess Inflow Design Flood (IDF)
4. Complete the Spillway Capacity Evaluation and Alternatives Analysis (to be further refined during subsequent analysis)

The Probable Maximum Flood (PMF) had been selected as the Spillway Design Flood (SDF) for the dam in the previous studies. A peak inflow of 42,500 cfs was estimated by RW Beck of Seattle WA, as described in their report titled "Hydrology/Hydraulics Analysis Summary Report- Lake Whitney Dam", dated October 1, 1997. This value was lower than the 48,600 cfs previously estimated by Department of the Army, Corps of Engineers, titled "Lake Whitney Dam, CT 00119, Phase 1 Inspection Report, National Dam Inspection Program", dated August 1981. The 1997 analysis predicted during the PMF event, a 500-foot long section of the non-overflow portion of the dam, as well as portions of Whitney avenue would be overtopped by 2.6 feet to 4.7 feet and the 250-foot-long spillway would be overtopped by 9.6 feet. This estimation was based on a simplified, uncalibrated hydrological model which modeled the contributing drainage area as a single catchment. RW Beck later performed additional analysis in 1999 in response to comments from Connecticut Department of Energy and Environmental Protection (CT DEEP) to evaluate the potential attenuation of inflows at three bridge crossing the reservoir. The attenuation was found to be minimal in the event of PMF.

Under our scope of work, GZA assessed the Lake Whitney Dam's watershed runoff response under various design storms up to and including the PMF. GZA reassessed the existing hydrologic analysis of the approximate 36 mi<sup>2</sup> contributing watershed, including calibration and verification of the model results to existing stream gage records (USGS Stream Gage 01196620, located within the Lake Whitney Dam's Catchment on Mill River Near Hamden, CT). GZA performed a semi-distributed hydrological model using HEC-HMS computer software by dividing the drainage area into 5 sub-catchments and calibrating the model with the stream gauge record in Mill River. Results from GZA's updated hydrological modeling estimate the PMF peak inflow to Lake Whitney to be 38,200 cfs.



GZA developed a two-dimensional (2D) hydrologic and hydraulic (H&H) model using HEC-RAS computer program to evaluate potential attenuation of peak flows by upstream roadway crossings and bridges. Results indicate minor attenuation of the peak inflow to 38,000 cfs at the dam with a resulting peak water surface elevation of 44.5 ft (NAVD88). The analysis indicates the PMF overtops the main embankment portion (i.e. non-overflow section) of the dam by at least 4.1 feet for a length of approximately 500 feet (i.e., top of dam elevation is 40.4 feet at its highest (NAVD88)).

GZA evaluated the appropriate SDF for the dam using the ICA/IDF methodology outlined in the referenced FEMA P-94 document. GZA performed dam break simulations during PMF and four incrementally smaller hypothetical flood scenarios. The results of the analysis are shown in 2-D form in **Appendix F** and in the form of inundation maps in **Appendix G**. It is GZA's opinion that Lake Whitney Dam's SDF should remain the PMF based on the results from the ICA, and the SDF inflow should be 38,000 cfs.

All the results in this report including the maps in **Appendices F** and **Appendix G** are based on the Lake Whitney Dam's existing geometry. Results of the hydraulic analysis for proposed design alternatives are presented in the 30% Design Basis Report which will be included as **Appendix H** once completed.

## 2.0 INTRODUCTION

The objective of the hydrology and hydraulics analysis is to update the estimate for the peak inflow and resulting peak water surface elevation at the dam during the design flood to support design for remedial measures to improve dam safety and reduce potential risk of failure due to overtopping. The intent of the analysis is to update the hydrology and hydraulics (H&H) analysis for Lake Whitney Dam based on the state of the practice guidance. As part of this evaluation, GZA completed the following tasks:

1. Review the previous analyses and available information
2. Update the previous Probable Maximum Flood Study
3. Perform an Incremental Consequence Analysis (ICA) / Assess Inflow Design Flood (IDF)
4. Complete the Spillway Capacity Evaluation and Alternatives Analysis (to be further refined during subsequent analysis)

This report references elevations in North American Vertical Datum of 1988 (NAVD88) in units of feet. Elevation data collected as part of this analysis, including topographic survey, bathymetric survey, and LiDAR data were provided in NAVD88. Most of the information for the dam was provided in an unspecified local datum, referenced as the "USGS Datum" which identifies the dam spillway elevation as 36.48 feet, and crest elevation as 41.4 feet. The spillway elevation was measured to be 35.0 feet during the site-specific topographic survey completed in June-July 2019 by Alfred Benesch & Company. The crest elevation was measured as 39.9 to 40.4 feet during the same survey, i.e. the difference in crest and spillway elevations in the new survey was about 0.5 foot higher than previously reported and as a result the conversion from USGS Datum to NAVD88 is assumed to be approximately as follows:

$$\text{NAVD88} = \text{"USGS Datum"} - 1.0 \text{ to } 1.48 \text{ feet}$$

## 3.0 SITE DESCRIPTION

Lake Whitney Dam is an earthen embankment and stone masonry dam that is located on the Mill River in New Haven County, Hamden/New Haven, Connecticut. The dam was originally constructed in 1861. The dam is currently used for water supply by the Authority for water supply. Based on review of available information, the spillway crest has been raised twice in the past: once in 1867-1869 by 4 feet with cemented stone masonry and then in 1916-1917 improvements



when it was lengthened to 250 feet and adjusted to its present elevation with concrete<sup>1</sup>. Overview of a few key parameters for the dam, reservoir and its catchment are presented in **Table 1**:

**Table 1. Overview of Lake Whitney Dam, Reservoir and Catchment**

Name	Lake Whitney Dam
NID ID	CT00119
Hazard Classification	Class C (High)
Dam Height	37 feet
Dam Length	750 feet
Spillway Length	250 feet
Spillway Type	Broad crested weir
Normal Freeboard	5 feet
Drainage Area	36.4 square miles
Impoundment Area (at principal spillway crest)	178 acres
NID Storage	3,600 acre-feet
Watercourse	Mill River

The dam is comprised of an earthen embankment on the upstream side of a near vertical dry rubble stone masonry wall and retrofitted concrete spillway on masonry walls on the left. The non-overflow portion of the dam is approximately 500 feet long with a maximum structural height of 37 feet and a hydraulic height of approximately 32 feet. There are two gate chambers and a screen chamber downstream of the dam. Approximately half of the spillway’s 250 feet length is composed of a masonry wall with retrofitted concrete cap. The rest of the spillway is fitted with a concrete cap and buttress, with 68 feet of the spillway built as a side-channel spillway that would have reduced capacity during the PMF.

GZA subcontracted with Alfred Benesch & Company, who performed topographic survey of the dam structure and vicinity in June-July 2019. Several of the key dimensions and elevations obtained from Benesch survey that were used in the analysis and are listed below for reference.

**Table 2. Structures at Lake Whitney Dam**

Structure	Length (ft, inches)	Elevation Surveyed (ft, NAVD88) <sup>2</sup>	Elevation (R.W. Beck 97) (ft, USGS) <sup>3</sup>
Side-channel spillway	68’ 0”	35.0	36.48
Spillway with concrete cap and buttress	57’ 9”	35.0	36.48
Spillway with concrete cap	124’ 3”	35.0	36.48
Dam crest	750’ 0”	40.4 - 39.9	41.4

#### 4.0 METHODOLOGY

GZA reviewed the previous studies by Department of the Army (DoA) in 1981 and R.W. Beck in 1997. The DoA performed a simplified analysis estimating a triangular PMF hydrograph peaking to 48,600 cfs using twice the standard project flood (outdated method) and estimating a spillway capacity of about 21% of PMF. R.W. Beach estimated the PMF based on a

<sup>1</sup> Photographs, Written Historical and Descriptive Data, Historical American Engineering Record, National Park Services (not dated)

<sup>2</sup> Measured during site-specific topographic completed by Alfred Benesch & Company (June, July 2019). Note that the conversion factor reported in section 2 is based on spillway elevation. The difference in all elevations in NAVD88 vs “USGS Datum” may vary.

<sup>3</sup> As reported in the 1997 Hydrology / Hydraulics Analysis Report and reported on subsequent site drawings



simplified, uncalibrated hydrological model which modeled the contributing drainage area as a single catchment. This approach produced more reliable estimates but did not attempt calibration based on recorded floods, nor did it account for varying response time in the sub-catchments. RW Beck later performed additional analysis in 1999 after comments from CT DEEP to include the attenuation of inflow hydrograph at three bridge crossing the reservoir. The attenuation was found to be minimal in the event of PMF, though the routing was done by dividing the reservoir in HEC-HMS, and not a hydraulic model (e.g. HEC-RAS).

GZA performed an updated and more detailed hydrological and hydraulic analysis modeling the Lake Whitney catchment, reservoir, spillway and downstream area, as outlined in this section.

#### 4.1 HYDROLOGICAL MODELING

Under the current assignment, GZA assessed the Lake Whitney Dam’s watershed runoff response under various design storms up to and including the PMF. GZA developed a detailed computerized simulation model of the contributing watershed to Lake Whitney Dam to reassess the hydrologic analysis of the 36.4 mi<sup>2</sup> watershed. The rainfall / runoff process was simulated by GZA using the US Army Corps of Engineers’ (USACE) HEC-HMS (version 4.3) computer program and unit hydrograph methodology. Unit hydrographs are the main tool for converting rainfall excess into runoff for gauged watersheds. GZA’s approach was to use Snyder Unit Hydrograph method and calibrate / verify its parameters for Lake Whitney Dam’s catchment. The calibration process involved simulating the flood flow hydrograph for three specific floods (i.e. candidate storms) at stream gauge (USGS 01196620) at Mill River, located within Lake Whitney Dam’s catchment about 6 miles upstream of the dam. The simulated hydrograph was compared to the observed recorded storm hydrograph, and key hydrologic input parameters were adjusted to approximately match observed data. The verification process involved using the calibrated hydrologic input parameters to simulate two separate historic floods at the same stream gage. The calibration / verification process is successful when an acceptable comparison of simulated versus observed stream flow data (e.g. peak flow rate and/or runoff volume) is achieved during the verification process. This methodology provided increased confidence in the model results and reduces the potential for grossly overestimating the inflow design flood.

The 72-hour PMP for the Lake Whitney Dam contributing watershed was created in HEC-HMS using NOAA Hydrometeorological Report No. 52 procedures<sup>4</sup>. Rainfall / runoff processes were modeled by GZA utilizing the Snyder Unit Hydrograph processes within HEC-HMS. Snyder’s Unit Hydrograph uses two parameters and two loss/infiltration parameters to model the unit hydrograph response of the watershed to a given rainfall event. The modeling procedure is as follows:

1. Estimate initial Snyder Unit Hydrograph parameters to develop a unit hydrograph using Snyder’s method for the gauging station USGS 01196620 at Mill River. These parameters are the watershed lag ( $t_p$ ) and peaking coefficient ( $C_p$ ). The acceptable range for peaking coefficient is between 0.4 and 0.8 (Bedient, 1992). A peaking coefficient of 0.6 was chosen as an initial estimate for model calibration (described below). The initial estimate for lag time was calculated by:

$$t_p = C_t(L * L_c)^{0.3}$$

Where:

$t_p$  : Watershed Lag (hr),

L : Length of the main stream from the outlet to the divide (mi),

---

<sup>4</sup> NOAA HYDROMETEOROLOGICAL REPORT NO. 52, Application of Probable Maximum Precipitation Estimates -United States East of the 105th Meridian, U.S. Department of Commerce National Oceanic and Atmospheric Administration, U.S. Department of The Army Corps Of Engineers, August 1982



- $L_c$  : Length along the main stream to the point nearest the watershed centroid (mi), and  
 $C_t$  : Coefficient usually ranging from 1.8 to 2.2, although it has been found to vary from 0.4 in mountainous areas to 8.0 along the Gulf of Mexico. An initial value of 2.0 was assumed.

The Snyder peak discharge equation is internal to the HEC-HMS model and is as follows:

$$Q_p = \frac{640 C_p * A}{t_p}$$

Where:

- $Q_p$  : Peak Discharge (cfs),  
 $C_p$  : Peaking Coefficient (dimensionless),  
 $A$  : Watershed Size (mi<sup>2</sup>), and  
 $T_p$  : Lag Time (hr).

2. Estimate initial conditions for constant and initial losses. Constant loss is estimated using published [USDA 1955] infiltration rates of the hydraulic soil groups within the watershed. The initial loss is estimated from the watershed's antecedent conditions prior to each storm.
3. Obtain historic flood information for the USGS streamflow and staff gauge. Additionally, obtain rainfall data corresponding to selected candidate flood.
4. Import these data into HEC-HMS and perform the calibration by iteratively adjusting the Snyder parameters (i.e. peaking coefficient and lag time,) and the loss parameters (i.e. initial and constant loss,) until the simulated runoff response reflects the observed response to the historic floods. The model is calibrated when the calculated hydrograph approximately reflects the observed hydrograph.
5. Verify model parameters using historical flood observations not used for calibration. This is done by comparing the observed response to the model simulated runoff response (maintaining the calibrated Snyder parameters and constant loss parameter,) while adjusting the initial loss parameter. The model is verified when an acceptable comparison of simulated results versus observed streamflow data is achieved for the verification storms.
6. Apply the calibrated and verified Snyder United Hydrograph parameters ( $C_p$  and  $C_t$ ) for the gauged watershed to the ungauged watershed in the HEC-HMS model. Use the calibrated and verified  $C_t$  to determine the lag time ( $t_p$ ) for the ungauged watershed.
7. Estimate Probable Maximum Precipitation (PMP) distribution using HMR-52 storm tool in HEC-HMS. (HMR-52 was developed based of Hydrometeorological Reports No. 51 and 52.)
8. Use the developed parameters and the PMP hyetograph to simulate the Lake Whitney Dam watershed response.

Results of Hydrological modeling, calibration, verification, and PMF simulation are presented in Section 5.

#### 4.2 HYDRAULIC MODELING

GZA developed a two-dimensional (2D) hydraulic model for the Lake Whitney Dam reservoir and downstream using HEC-RAS, Version 5.0.7<sup>5</sup> to analyze the routing within the reservoir and at the dam and evaluate potential attenuation of peak

---

<sup>5</sup> HEC-RAS, Version 5.0.7, US Army Corps of Engineers, March 2019.



flows by upstream roadway crossings and bridges. GZA input the peak PMF inflow to the upstream limit of Lake Whitney and evaluated the spillway routing capacity of the flood in the reservoir.

GZA evaluated the possibility of reducing the magnitude of the SDF using the Inflow Design Flood (IDF) methodology outlined in *Chapter 2: Selecting and Accommodating Inflow Design Floods for Dams*, of the *FERC Engineering Guidelines for the Evaluation of Hydropower Projects*<sup>6</sup> as well as documented in FEMA Selecting and Accommodating Inflow Design Floods for Dams FEMA P-94<sup>7</sup>. This incremental consequence analysis methodology involves comparison of downstream flooding impacts with and without dam failure. If the consequences of dam failure during a specific design flood are insignificant on top of inundation which would be expected as a result of natural flood flows, then the magnitude of the design flood may be reduced until the incremental affects are consequential. GZA used this methodology as a means of establishing the IDF and thereby potentially reducing the effort and cost of spillway rehabilitation.

GZA evaluated the incremental increase in consequences due to dam failure by routing a series of flows assuming: 1) the dam remains in place, and 2) the dam fails. In accordance with FERC methodology, the dam failure analysis was completed assuming that failure occurs at the peak of the flood hydrograph. GZA followed the specific guidance and procedures outlined in Appendix II-C of the FERC Guidelines. The same computer model used in routing of PMF was used to evaluate water level downstream of the dam due to natural flows versus those resulting from a dam breach. The incremental increase in downstream, water surface elevation between the no dam failure and the dam failure conditions was estimated. GZA continued to route varying flows, using our HEC-RAS model, until the incremental rise in flood water downstream indicates adverse consequences; this resultant flow determines the IDF for the Project. GZA used engineering judgment, and guidelines developed by U.S. Bureau of Reclamation (USBR)<sup>8</sup> in evaluating consequences. One of the key parameters used to evaluate the “adverse consequences” was the product of depth and velocity (DV) created by the dam break flood wave.

The Lake Whitney Dam flood routing and breach scenarios were modeled using the unsteady, mixed flow regimes within HEC-RAS. GZA’s HEC-RAS model included the Mill River from about 2.2 miles upstream of Lake Whitney Dam (at the upstream limits of the impoundment) to the confluence with Quinnipiac River at Long Island Sound 2.6 miles downstream of the dam. GZA simulated the reservoir and downstream area in the 2-dimensional model using the terrain downstream. An area of concern that was specifically included in the model was the railway crossing where there is potential for 2-dimensional flow during large floods is very high. The HEC-RAS model uses High Resolution Subgrid Modeling to describe the river as a 2-dimensional flow area (i.e. each computational cell and cell face are based on details of the underlying terrain).

GZA used UConn LiDAR data and depth measurements from 2019 bathymetric survey completed by Alfred Benesch & Company to develop the terrain model. Comparison of the 2019 bathymetric survey with the 2000 survey by Milone & MacBroom indicates that the 2000 survey is generally similar to that recently completed. The LiDAR data was extracted in 2016 and provided to GZA as DTM mosaics with elevation in meters NAVD88. The minimum streambed elevation of the Mill River was not captured by the LiDAR data. GZA therefore combined the mosaics and lowered the reservoir bottom based on 2019 bathymetric survey results using ArcGIS<sup>9</sup>.

The dam was modelled as a 2D area connection structure, with the top of dam and spillway crest elevations based on field measurements by GZA’s subconsultant, Benesch. Three bridges upstream of the reservoir were modelled as 2D area connection culverts to assess the attenuation of inflow flood in the reservoir. The bridges downstream were only included

---

<sup>6</sup> Chapter II, Selecting and Accommodating Inflow Design Floods for Dams, Engineering Guidelines for the Evaluation of Hydropower Projects Federal Energy Regulatory Commission (FERC), August 2015

<sup>7</sup> Selecting and Accommodating Inflow Design Floods for Dams FEMA P-94, August 2013

<sup>8</sup> Guidelines for Estimating Life Loss for Dam Safety Risk Analysis, U.S. Department of the Interior, Bureau of Reclamation, Feb 2014

<sup>9</sup> ArcGIS Desktop, Version 10.6.1, ESRI Inc., 2019



with their abutments. GZA assigned distributed Manning's "n" roughness coefficients based on land use from the 2011 National Land Cover Database<sup>10</sup>.

Dam failure is modeled in HEC-RAS by assigning breach characteristics (i.e., the size and shape of the breach, breach formation time). HEC-RAS computes an outflow hydrograph at the dam and routes the hydrograph through the downstream channel. The hydrograph is typically translated and attenuated as it progresses downstream due to variations in channel valley geometry/storage, roughness, lateral inflows/outflows, acceleration effects, and hydraulic structures such as dams and bridges. The timing and extent of flooding at each cross section downstream of the breached dam can be extracted from HEC-RAS. Information such as peak flows, maximum water surface elevations (i.e., stage), and arrival time of the leading edge and maximum flood stage are useful outputs extracted from the model. Inundation mapping was then developed using the results from the HEC-RAS analysis. The inundation maps, including water depth and velocity are calculated in RAS Mapper and exported to ArcMap. Results of hydraulic modeling of hypothetical dam breach are presented in Section 6.

## 5.0 HYDROLOGICAL ANALYSIS

### 5.1 CONTRIBUTING DRAINAGE AREA

The total drainage area to Lake Whitney Dam is approximately 36.4 sq. mi according to USGS online catchment delineator tool StreamStats which creates catchment area of a given point using topographic data. GZA verified and confirmed the catchment using available topographic data (LiDAR), and sub-divided the total catchment area into 4 sub-catchments to calibrate the watershed runoff response to streamflow data at the Mill River gauging station and to model runoff inflow to Lake Whitney. GZA modeled four sub-catchments including: Drainage to the USGS 01196620 Gauging station on Mill River, Shepard Brook Tributary, rest of Mill River down to the inflow point at the reservoir, and local inflow to Lake Whitney. A drainage area map, including the location of the USGS gauges, is presented in **Figure 1**.

---

<sup>10</sup> NLCD 2011 Land Cover (2016 Edition), digital GIS data made available by ESRI ArcGIS Online

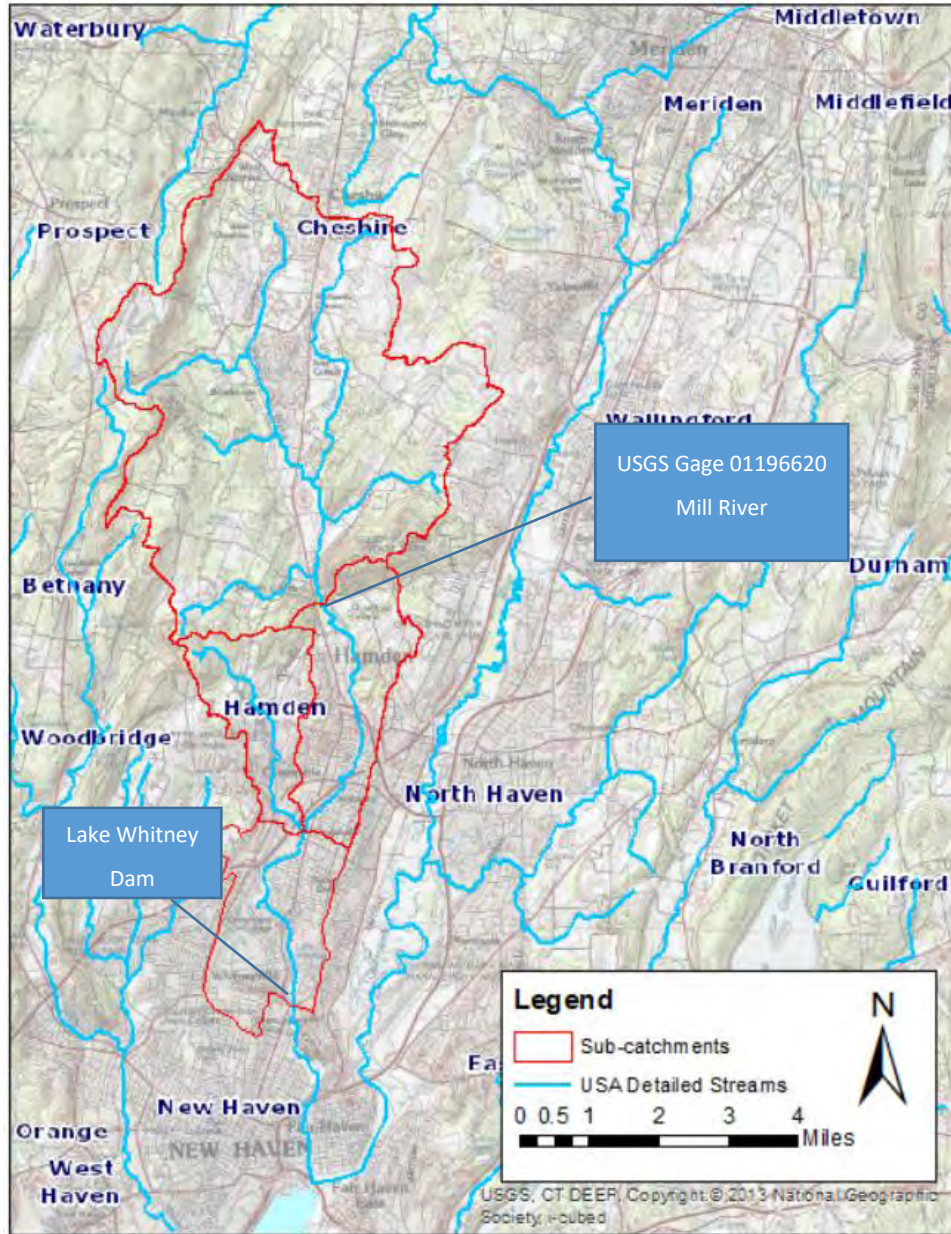

Figure 1: Lake Whitney Dam's sub-catchment delineations

## 5.2 PRECIPITATION DATA

Local rainfall estimates for historical floods are required to calibrate a gauged watershed's response. GZA collected precipitation data from the following stations in Connecticut (Figure 2):

- 068330: Thomaston Dam in Thomaston, CT, 12 miles northwest of the catchment, period of record: 1961-2014
- 063451: Hartford Brainard Field, 25 miles northeast of the catchment, period of record: 1947-2008
- 061488: Cockaponset Ranger Station, 20 miles east of the catchment, period of record: 1978-2012
- 060806: Igor I Sikorsky Memorial Airport, 20 miles southwest of the catchment, period of record: 1948-2013



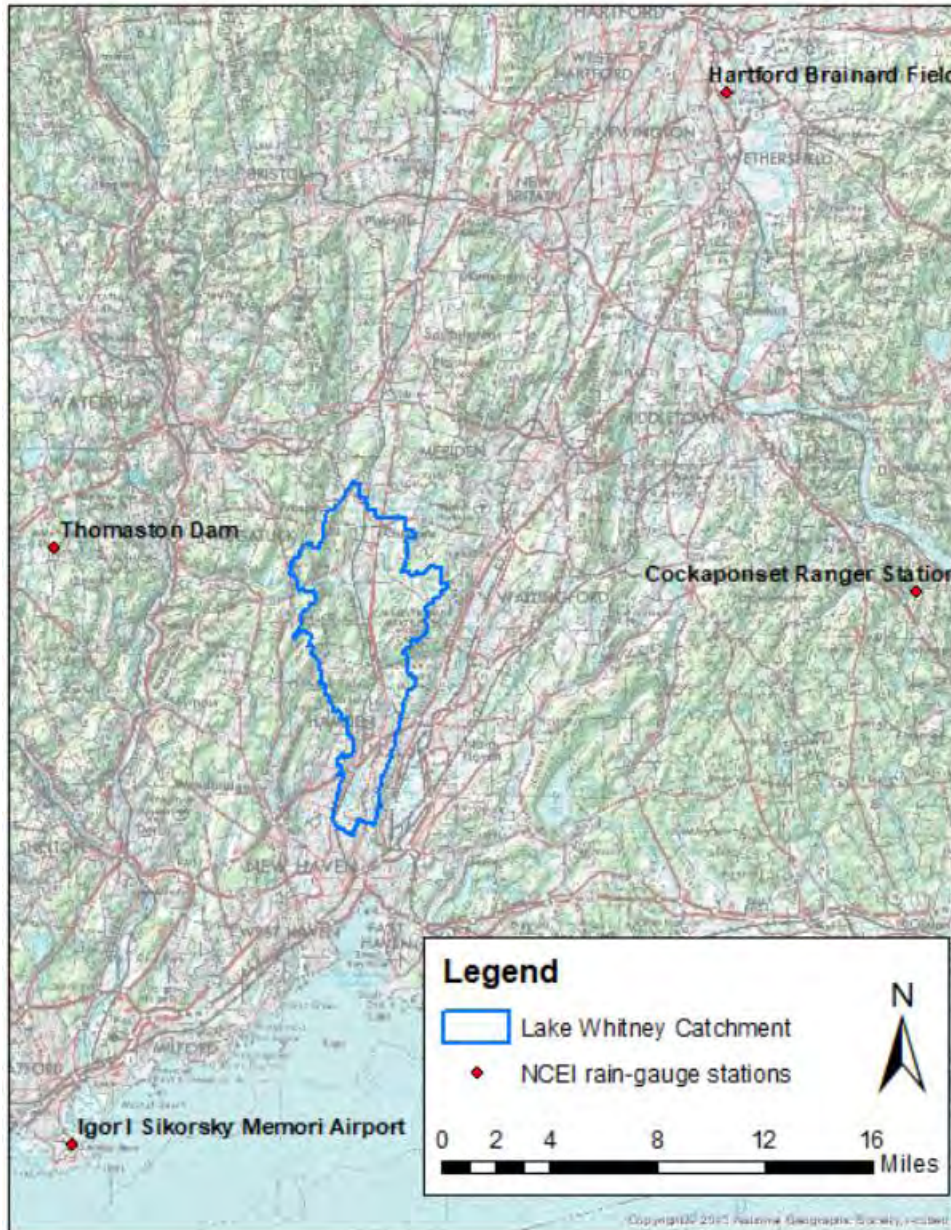

Figure 2: Stations with precipitation Data available from NOAA's National Centers for Environmental Information (NCEI)

Precipitation in Lake Whitney Dam’s catchment was estimated based on the available data. Based on the location of the rain gauges and relatively small size of Lake Whitney’s catchment compared to the distances between gauges, GZA used the inverse distance method:

$$w_{ug} = \frac{1}{\sum_{i=1}^I \frac{1}{d(u,i)^c}} \cdot \sum_{g=1}^G \frac{1}{d(u,g)^c}$$



Where  $w_{ug}$  is the weight of gauge  $g$  on location  $u$ ,  $c$  is an exponent assumed 1 for inverse distance method, and  $d(u,g)$  and  $d(u,i)$  are the distances from the gauge to the center of Lake Whitney’s catchment.

### 5.3 STREAMFLOW DATA

Daily flow data at USGS 01196620 gauging station on the Mill River, located about 6 miles north of the Lake Whitney Dam, is available from 1968 to Present, with missing data from October 1970 to October 1978. There are limited stream gage records at USGS 01196626 Mill River at Hamden, CT, from 1974 to 1978, which was located immediately downstream of the dam, and likely were collected for a short period when the upstream gage was moved. Streamflow data recorded at 15 min intervals are also available for flow after October 1990 with missing data between October 1994 and April 1996. Significant floods occurred within the Mill River watershed during all seasons, with the flood of record occurring in June 1982.

GZA also used this gauging station to perform Flood Frequency Analysis using Army Corps of Engineers’ HEC-SSP (version 2.1.1.137) computer program and Bulletin 17C/EMA (Expected Moments Algorithm) procedure. The results for return periods of up to 500 year are summarized in **Table 3**. When scaled for the drainage area, the estimated 100- and 500-year (1% and 0.2% annual chance of occurrence) peak inflows to Lake Whitney are 9,060 and 11,630 cfs, respectively. Peak flood estimates for the Mill River at Lake Whitney Dam are also available in Federal Emergency Management Agency (FEMA) Flood Insurance Study (FIS) for New Haven County, CT<sup>11</sup>. The estimations included within the FIS are based on weighted flood-frequency estimates of gage data and USGS Regional Regression Equations developed in 2004. Compared to the FEMA study, the peak discharges estimated using HEC-SSP for stream gage records from 1969 to 2014 are mostly higher. The FIS includes flood profiles for the Mill River at the Lake Whitney Dam, and the 100- and 500-year peak water surface elevations in Lake Whitney are approximately 38 and 41 feet (NAVD).

**Table 3. Flood Frequency Analysis, results at the gauging station on Mill River**

Annual Percent Chance Exceedance	Estimated Peak Flow at USGS 01196620 (cfs)	Confidence Limit 0.05 (cfs)	Confidence Limit 0.95 (cfs)	FEMA Peak Discharges at Lake Whitney Dam (cfs)	Inflow to Lake Whitney Reservoir, scaled based on USGS 01196620 (cfs) <sup>b</sup>
0.1	<b>9,500</b>	50,887	5,446	-	<b>13,930</b>
0.2	<b>7,900</b>	35,068	4,816	8,780	<b>11,630</b>
0.5	<b>6,150</b>	20,123	4,034	-	<b>9,060</b>
1	<b>5,030</b>	13,045	3,479	5,950	<b>7,410</b>
2	<b>4,060</b>	8,503	2,952	4,940	<b>5,990</b>
5	<b>2,980</b>	4,884	2,298	-	<b>4,400</b>
10	<b>2,290</b>	3,253	1,831	2,970	<b>3,380</b>
20	<b>1,690</b>	2,176	1,383	-	<b>2,490</b>
50	<b>980</b>	1,183	816	-	<b>1,450</b>

<sup>a</sup> Peak streamflow estimated at USGS 01196620 using HEC-SSP

<sup>b</sup> Peak streamflow estimated at Lake Whitney Dam, scaled USGS 01196620 estimates based on drainage area

### 5.4 CALIBRATION AND VERIFICATION

As described in section 4.1, GZA’s used Snyder Unit Hydrograph methodology and calibration / verification of its parameters for Lake Whitney Dam’s sub-catchments. The calibration process involved simulating the flood flow

<sup>11</sup> FLOOD INSURANCE STUDY NUMBER 09009CV001D, FEMA, May 2017



hydrograph during three specific floods at stream gauge (USGS 01196620) and adjusting the sub-catchment’s hydrologic parameters in order to reproduce the observed recorded storm hydrograph. The verification process involved using the calibrated hydrologic input parameters to simulate two separate historic floods at the same stream gage. The calibration / verification process is successful when an acceptable comparison of simulated versus observed stream flow data (e.g. peak flow rate and/or runoff volume) is achieved during the verification process.

#### 5.4.1 Candidate Storms

GZA reviewed the available streamflow data from 1968 to 2019 and selected three floods to use in the model calibration process and two additional floods for use in the verification process. A summary of the floods selected for the calibration and verification is provided in **Table 4** below. Descriptions of each of the floods are also detailed in the subsections which follow.

**Table 4. Overview of historical storms used for calibration and verification at USGS 01196620**

Date	Peak Flood (cfs)	Estimated return period (years)	Used for
6-Jun-82	5,580	100-200	Verification
6-Jun-92	2,350	10-20	Calibration
16-Apr-96	2,180	5-10	Verification
15-Apr-07	1,940	5-10	Calibration
23-Apr-06	1,520	2-5	Calibration

The June 1992 flood was the second largest flood recorded in the Mill River at gauging station USGS 01196620. The storm occurred on June 5, 1992 and resulted in approximately 4.1 inches of precipitation in less than a 24-hour period. The recorded flow data at the Mill River gauging station show volume corresponding to about 90% total precipitation.

The April 2007 storm began on April 15th, 2007 resulting in a precipitation depth of 5.7 inches in less than a 24-hour period in the gauging station’s catchment (inverse distance average of Thomaston Dam and Igor Sikorsky rain gauges). The recorded flow data at Mill River gauging station show a peak flood of 1,940 cfs, and a volume corresponding to about 75% total precipitation. This indicates relatively high precipitation loss.

The April 2007 storm began on April 23rd, 2006 resulting in a precipitation depth of 4.5 inches of precipitation in less than a 24-hour period in the gauging station’s catchment (inverse distance average of Thomaston Dam and Igor Sikorsky rain gauges). The recorded flow data at Mill River gauging station show a volume corresponding to about 63% total precipitation. This indicates relatively high precipitation loss.

The June 1982 event is the flood of record at the gauging station at Mill River, bringing a total of 9.7 inches of rainfall from June 4<sup>th</sup> to June 7<sup>th</sup>. This is estimated based on available precipitation data from rain-gauges and calculating a weighted average (10% Thomaston Dam, 90% Cockaponset station) based on spatial distribution of the precipitation developed by National Weather Services (Figure 3), which shows high precipitation in Hamden with extremely high values at Cockaponset rain gauge.

Only daily discharge data (and not 15-min data) is available for the June 1982 flood in the Mill River Gauging Station, along with an instantaneous peak of 5,580 cfs. Therefore, the flood volume cannot be accurately estimated, and only peak value and timing was used for verification.



### June 4-7, 1982 Rainfall

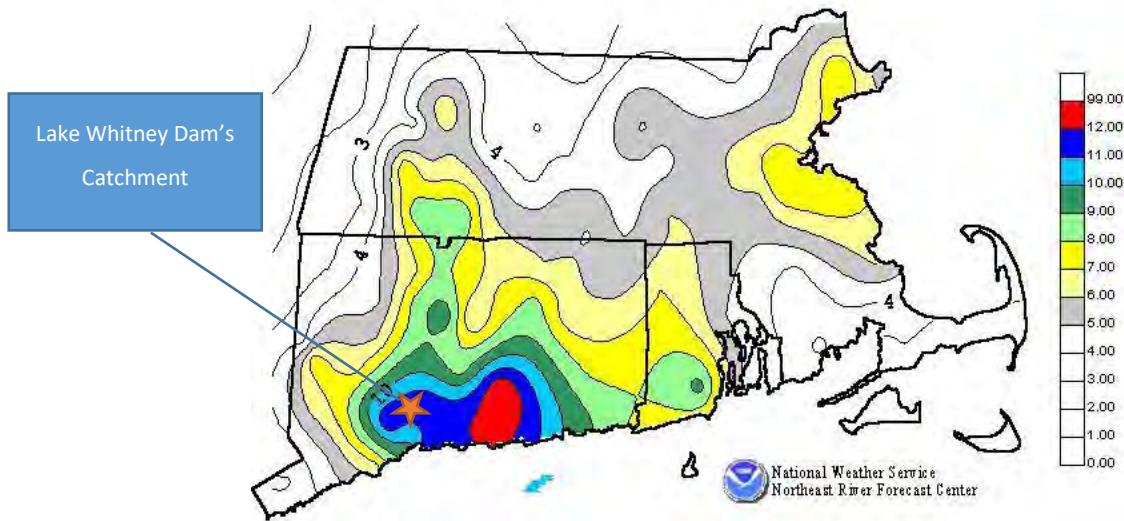

Figure 3: Rainfall totals across Southern New England from June 4-7, 1982 (weather.gov) Lake Whitney's catchment marked on the map

The April 1996 storm began on April 16th and resulted in an estimated 3.6 inches of precipitation in less than a 24-hour period in the gauging station's catchment (inverse distance average of Thomaston Dam and Igor Sikorsky rain gauges). The recorded flow data at Mill River gauging station show volume corresponding to about 92% total precipitation. The flood resulted from by intense precipitation with duration and peaking similar to other storms, although multiple snowfall events occurred prior to the April 16<sup>th</sup> storm, with the last one occurring on April 10<sup>th</sup>, which could explain relatively higher flood volume compared to other floods.

#### 5.4.2 Results

Throughout the calibration and verification process, GZA simulated the watershed response of Mill River at the gauging station as emanating from four sub-catchments listed in Section 5.1, plus direct precipitation on the reservoir. Flow at the gauging station was modeled and compared to the observed flow, as discussed above. Calibration model setup and full results are provided in **Appendix C**. In general, the flood volume is slightly (i.e. less than 10%) underestimated during calibration, particularly at the receding limb of the hydrographs when baseflow plays a larger role than the direct runoff. The receding limb volume difference is judged to be a result of our baseflow simplification assumption. Given the relatively small reservoir size (3,600 ac-ft) compared to expected PMF volume as described in Section 5.6 (more than 58,000 ac-ft), GZA gave priority to replicating/exceeding the observed peak flood rather than the flood volume. In GZA's opinion, the parameters, as summarized herein, resulted in a reasonable fit of the calibration of the three flood scenarios within Mill River gauging stations, as shown in **Table 5**.



**Table 5. Summary of calibration results**

Unit Hydrograph Input Parameters and results	Optimized Value for 1992 Storm	Optimized Value for 2007 Storm	Optimized Value for 2006 Storm
<b>Snyder Unit Hydrograph - Peaking Coefficient</b>	0.55	0.40	0.40
<b>Snyder Unit Hydrograph - Standard lag</b>	8.00	7.00	8.00
<b>Precip Loss- Initial Loss</b>	0.50	0.20	1.00
<b>Precip Loss- Loss rate</b>	0.05	0.04	0.15
<b>Peak (cfs) Calculated</b>	2,538	2,153	1,580
<b>Peak (cfs) Observed</b>	2,350	1,940	1,520
<b>Volume (in) Calculated</b>	3.20	4.24	2.57
<b>Volume (in) Observed</b>	3.45	4.71	2.76

Based on the above results, GZA applied the following calibrated Snyder Unit Hydrograph parameters for Lake Whitney Dam:  $C_t$  lag coefficient is 3.1, and peaking coefficient is 0.54. GZA estimated that the calibrated value for constant loss rate is 0.04 inches per hour. Using these Snyder Unit Hydrograph parameters, GZA simulated the runoff process for two storms: June 1982 and April 1996. To verify the modeled watershed response, GZA compared the simulated results of each flood to the observed flow at the gauging station. The results are summarized in **Table 6**.

**Table 6. Summary of verification results**

Unit Hydrograph Input Parameters and results	Optimized Value for 1982 Storm	Optimized Value for 1996 Storm
<b>Snyder Unit Hydrograph - Peaking Coefficient</b>	0.54	0.54
<b>Snyder Unit Hydrograph - Standard lag</b>	7.50	7.50
<b>Precip Loss- Initial Loss</b>	0.01	0.50
<b>Precip Loss- Constant Loss rate</b>	0.04	0.04
<b>Peak (cfs) Calculated</b>	5,630	2,137
<b>Peak (cfs) Observed</b>	5,580	1,950
<b>Volume (in) Calculated</b>	-	3.01
<b>Volume (in) Observed</b>	-	3.38

For both storms, GZA’s calibrated parameters approximately matched the peak flow and peaking time (for 1996 flood), which in GZA’s opinion are key criteria for model performance. The 1982 peak is overestimated by 1%, while 1996 peak is overestimated by 9%. The flood volume for 1996 is underestimated by only 11%, which is partially due to some unaccounted snowfall in early April 1996. There is no accurate estimate for observed volume and peaking time for 1982 flood, therefore only peak value is assessed for this flood.

The result of calibration and verification are summarized in **Table 7** below. Note that the initial precipitation loss during PMP is conservatively disregarded for all sub-basins. FERC guideline for Determination of PMF<sup>12</sup> recommends setting the

<sup>12</sup> Chapter VII, Determination of the Probable Maximum Flood, Engineering Guidelines for the Evaluation of Hydropower Projects Federal Energy Regulatory Commission (FERC), September 2001



initial loss to zero, unless a specific hydrologic condition, such as substantial depression storage, justify otherwise. This is because the peak flow will almost always be insensitive to the initial loss, as will the flood volume in the vicinity of the peak.

**Table 7. Parameters based on calibration and verification**

Parameter/Catchment	Gauging Station on Mill River	Mill River local Basin	Shepard Brook	Local inflow to reservoir
C <sub>t</sub>	3.1	3.1	3.1	3.1
L (mi)	7.25	3.7	3.2	1
L <sub>c</sub> (mi)	2.5	1.7	1.8	0.5
Lag time (hr)	7.5	5.5	5.3	2.6
C <sub>p</sub>	0.54	0.54	0.54	0.54
Constant Loss Rate (in/hr)	0.04	0.04	0.04	0.04

### 5.5 PMP

GZA derived the 72-hour PMP for each sub-watershed in the Lake Whitney Dam model using NOAA Hydrometeorological Report No. 52 procedures in the HEC-HMS program. The 72-hour PMP has a storm area of 50 square miles, which results in the highest precipitation volume in the catchment when using the standard Isohyetal pattern recommended. The storm is centered over the watershed centroid and is oriented at 179 degrees from north, which is less than 40 degrees from the preferred orientation of 197 degrees. Total 72-hour area weighted PMP volume was computed to be 34.2 inches. **Table 8** shows the total volume of rainfall for each sub-catchment in the PMF model for a 72-hour duration storm and the area weighted PMP average. This is about 1 percent less than the 72-hour PMP total of 34.6 inches estimated by R. W. Beck as part of the original 1997 HEC-1 PMF analysis. Results from HEC-HMS for simulation of PMP are presented in **Appendix D**.

**Table 8. HMR 51/52 Derived PMP Depths for PMF Model Elements**

Parameter/Catchment	Gauging Station on Mill River	Mill River local Basin	Shepard Brook	Local inflow to reservoir	Direct precipitation on reservoir	Area weighted PMP average
Area (mi <sup>2</sup> )	24.5	4.5	3.2	3.6	0.4	36.4
Total Precipitation (in)	34.4	35.3	35.3	32.6	33.3	34.2

### 5.6 PMF

The HEC-HMS analysis resulted in an estimated PMF peak inflow to Lake Whitney of 38,200 cfs with a flood volume of 58,170 ac-ft. The flood volume is similar to 58,230 ac-ft by R. W. Beck<sup>13</sup>, but the peak is approximately 10% lower than 42,500 cfs reported, which is due sub-dividing the total drainage area and updating watershed parameters through calibration and verification. The results of hydrological modeling for Lake Whitney Dam’s catchment is presented in the **Figure 4**.

<sup>13</sup> Lake Whitney Dam Hydrology/Hydraulic Analysis and Stability Analysis Report, R. W. Beck, Oct 1997

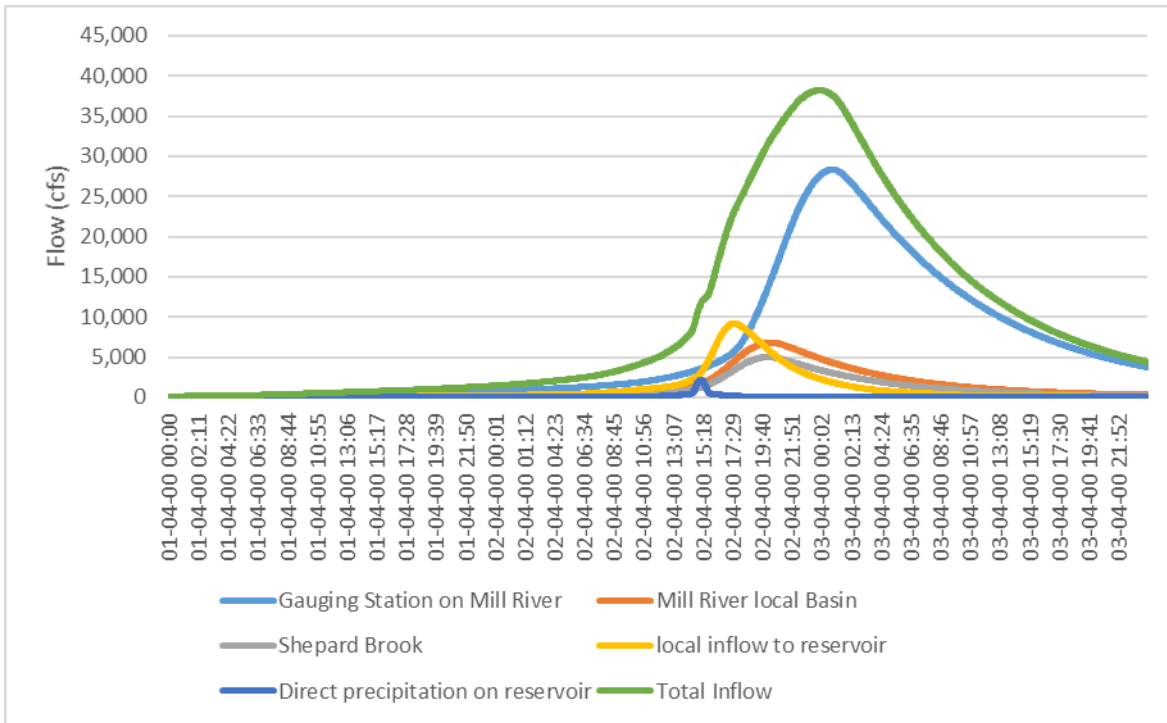

Figure 4: Results from PMF simulation in HEC-HMS

### 5.7 ROUTING

GZA then simulated the PMF hydrograph within the 2-D HEC-RAS model developed by GZA (details in Sections 4.1 and 6.1). The peak flood is attenuated to 38,000 cfs at Lake Whitney Dam, raising the reservoir water elevation to 44.5 ft. Spillway flow depths of 9.5 feet were estimated. Overtopping of the top of dam crest (i.e. non-overflow section) by at least 4.1 feet was predicted (based on dam crest elevations ranging from El. 39.9 to 40.4). Based on predicted reservoir level, the anticipated flow depths in Whitney Avenue on the right side of the dam will range from 0 to 5 feet. There are three bridges on the reservoir which restrict and attenuate smaller floods, but these bridges are completely overtopped during the PMF, consequently, they do not provide substantial attenuation during the PMF event. The PMF overtopping depths of these upstream bridges are as follows: Waite Street Bridge by more than 10 feet, Whitney Avenue Bridge by about 3 feet, and Davis Street Bridge by more than 4 feet.

The table below summarizes GZA’s results in comparison with previous studies by Department of the Army in 1981 and R.W. Beck in 1997.

**Table 9. Results for PMF routing compared to previous studies**

Study/results	PMF inflow cfs	PMF outflow cfs	PMF Headwater Feet (NAVD88)	PMF volume ac-ft	Overtopping feet
1981 ACOE	48,600	46,500	44.8*	-	4.4
1997 R. W. Beck	42,500	42,100	45.1*	58,200**	4.7
2019 GZA	38,200	38,000	44.5	58,200	4.1

\* Converted from USGS elevations

\*\* Estimated based on reported PMF hydrograph



## 6.0 INCREMENTAL CONSEQUENCE ANALYSIS (ICA)

GZA evaluated the possibility of reducing the magnitude of the SDF by performing Incremental Consequence Analysis (ICA) outlined by FERC for selection of appropriate inflow design, as described in Section 4.2 of this report. This ICA methodology involves comparison of downstream flooding impacts with and without dam failure. If the consequences of dam failure during a specific flood are consequential on top of inundation which would be expected as a result of natural flood flows, then the magnitude of the design flood may be increased until the incremental effects are insignificant. GZA has used engineering judgment in estimating the flow for which no adverse consequences result. As outlined in Section 6.4, this process includes assessing the product of depth and velocity created by the flood wave to determine the appropriate inflow design flood for the dam.

### 6.1 MODEL EXTENTS

The extents of GZA’s 2D HEC-RAS model includes the entirety of Lake Whitney extending approximately 2.2 miles upstream of Lake Whitney Dam to the confluence to the downstream limit of the model at the confluence with the Quinnipiac River at Long Island Sound 2.6 miles downstream of the dam. GZA modelled the reservoir and downstream area using a 2D model given the terrain downstream, especially at the railway crossing where there is potential for 2-dimensional flow during large floods. The model extent is approximately 0.5 acre and contains 17,800 cells. Cell sizes vary based on the geometry of the river, dam and bridges, ranging from 100 ft in floodplain to 20 ft at the dam. The hydraulic model is presented in Appendix E.

The dam was modelled as a 2D area connection structure, with the crest and spillway elevations based on dam geometry (Table 1). Discharges at the dam structure are modelled using the weir equation. During normal to high flows weir coefficients of 3.2 for the spillway and 2.8 for the dam crest<sup>14</sup>. However, headwater at the spillway is significantly higher during PMF, exceeding 8 feet. Therefore, these weir coefficients increase to 3.5 and 3.2 for the spillway and dam crest, respectively, during simulation of the PMF<sup>15</sup>. Three bridges upstream of the reservoir were modelled as 2-D area connections based on inspection reports provided by Connecticut Department of Transportation<sup>16</sup>, City of Hamden<sup>17</sup> and visual estimates.

Manning’s “n” roughness coefficients used in the HEC-RAS model generally ranged from 0.025 to 0.10. GZA assigned distributed Manning’s n values based on land use from the 2011 National Land Cover Database (Table 10):

**Table 10. Manning’s n Values for Different Land Use**

Land Use Classification	Manning's n	Land Use Classification	Manning's n
Barren Land	0.025	Evergreen Forest	0.100
Deciduous Forest	0.100	Grassland/Herbaceous	0.035
Developed High Intensity	0.120	Mixed Forest	0.100
Developed Low Intensity	0.080	Open Water	0.030
Developed Medium Intensity	0.080	Pasture/Hay	0.030
Developed Open Space	0.040	Shrub/Scrub	0.070
Emergent Herbaceous Wetlands	0.040	Woody Wetland	0.040

<sup>14</sup> HEC-RAS River Analysis System, Hydraulic Reference Manual, USACE, Jan 2010

<sup>15</sup> Handbook of Hydraulics, 6<sup>th</sup> edition, Ernest Frederick Brater, Horace Williams King, 1976

<sup>16</sup> BRIDGE NO.06150, Routine and Underwater Inspection, Dec 2018

<sup>17</sup> Rehabilitation Study Report, Bridge No. 04168, Apr 2014





## 6.2 INITIAL AND BOUNDARY CONDITIONS

For the initial flood scenarios, GZA used hypothetical floods up to 38,000 cfs, i.e. the PMF developed in the calibrated semi-distributed hydrological model in HEC-HMS, as described in Section 5.7 of this report. For the initial conditions, the reservoir is filled up with water elevation stabilized for each flood scenario. The scenarios are listed in **Table 11**. The downstream boundary condition at the confluence with the Quinnipiac River at Long Island Sound was a normal water level for each cell face along the boundary, assuming a flat riverbed.

**Table 11. Hypothetical flood scenarios for Incremental Consequence Analysis (ICA)**

Flood scenario	Q (cfs)
<b>A</b>	15,000
<b>B</b>	20,000
<b>C</b>	30,000
<b>D</b>	35,000
<b>E</b>	38,000 (PMF)

## 6.3 ASSUMED DAM BREACH PARAMETERS

Dam breach parameters such as time of breach formation, breach shape, and the average width of the breach were selected based on the type of materials used in constructing the dam. These parameters were selected in accordance with the recommended range of values published in the FERC guidelines and based on engineering judgment. FERC provides a range of breach width, time to breach, and breach side slopes for use in a dam breach analysis.

The dam consists of a mixture of dry rubble, masonry and retrofitted concrete, with upstream earth embankment. Given that the core of the dam is composed of dry rubble, GZA modeled the breach width based on FERC guidelines for earth embankment dams: breach width ranges between one to five times the dam height. FERC guidance indicates the time of failure ranges between 0.1 and 0.5 hour. GZA used an average breach width of three times the dam’s height, corresponding to 111 feet (i.e. breach bottom width of 92.5 feet). Since the collapse of the masonry and rubble dam can occur much more rapidly than an average earthen embankment dam, GZA conservatively assumed a time of breach of 0.1 hour. The parameters for the breached dam are summarized in **Table 12**:

**Table 12. Wet Weather Dam Break Input Parameters Summary**

Parameter	Value
Top of Dam Elevation (feet, NAVD88)	39.9 – 40.4
Breach Formation Shape	Trapezoid
Average Breach Width (feet)	111
Breach Bottom Width (feet)	92.5
Breach Bottom Elevation (feet, NAVD88)	4.5
Final Breach Side Slope (H : V)	1:2
Time to Maximum Breach (hours)	0.1

## 6.4 RESULTS

The results of the analysis are shown in tabular form in **Appendix F** and the inundation maps are provided in **Appendix G**. The inundation maps show the expected flood zone impacted by the PMF without dam failure and with dam failure. To preliminarily estimate the incremental increase in water surface elevation, the simulations were run with inflow hydrographs (5,000 to PMF, with smaller floods scaled based on PMF hydrograph) with dam breach at the peak water



level. The rise in water level downstream, as well as initial and maximum depths and velocities was estimated in the following critical locations:

Location 1- At Eli Whitney Museum and Workshop, 350 feet downstream of the dam

Location 2- At Wilbur Cross High School, 0.8 mile downstream of the dam

Location 3- Upstream Interstate-91 bridges, 1.4 miles downstream of the dam

Location 4- At Ball Island, 1.9 miles downstream of the dam

Location 5- At G T Wholesale Yard, 2.2 miles downstream of the dam

GZA simulated eight breach scenarios. The results for dam breach during floods higher than 500-year flood are summarized in the **Table 13** and **Appendices F**.

**Table 13. Summary of ICA Result**

Result/Scenario	A	B	C	D	E
Initial Flood (cfs)	15,000	20,000	30,000	35,000	38,000
Peak Flow at the dam during breach (cfs)	46,410	49,380	55,840	59,740	61,960
Incremental Increase in Water Surface Elevation at Location 1 (ft)	4.4	3.6	2.7	2.2	2.2
Incremental Increase in Water Surface Elevation at Location 2 (ft)	3.4	2.8	2.0	1.9	1.6
Incremental Increase in Water Surface Elevation at Location 3 (ft)	3.4	2.8	2.0	1.8	1.5
Incremental Increase in Water Surface Elevation at Location 4 (ft)	2.5	1.9	1.1	1.2	1.1
Incremental Increase in Water Surface Elevation at Location 5 (ft)	2.9	2.3	1.8	1.4	1.2

In addition to water level rise, the product of depth and velocity (DV) was examined in each location. Locations 1 and 2 were critical given higher occupancy buildings, i.e. Eli Whitney Museum and Workshop with and Wilbur Cross High School.

At location 1, the initial DV during floods 30,000 cfs and larger is about 60 ft<sup>2</sup>/s, which according to US Bureau of Reclamation corresponds to medium flood severity and possibility for loss of life before the dam breach. However, DV at this location is almost doubled during dam break, which will significantly increase fatality rate. At location 2, DV increases from approximately 20 to 40 ft<sup>2</sup>/s for dam break during floods of 30,000 cfs and higher; Average depth at Wilbur Cross High School during dam break increases to above 14 feet. Although consequences of natural flooding are already significant in some locations downstream of the dam, incremental consequences as a result of dam failure represent an appreciable, additional hazard to life and property at Wilbur Cross High School (location 2), in GZA’s opinion. In addition, this location is about 0.8 mile downstream of the dam with only a few minutes time for arrival of the dam break wave and less than half an hour time until the peak water level, which means warning and response time will be very limited.

Lake Whitney Dam is currently classified as a High Hazard Dam (i.e. loss of life is likely). The dam is regulated by Connecticut Dam Safety Program administered by the Connecticut Office of Energy and Environmental Protection (CTDEEP). Based on the model results, it is GZA’s opinion that Lake Whitney Dam should remain classified as a High Hazard Dam, and the dam’s Inflow Design Flood should remain the PMF.



## **Appendix A – Limitations**



## **USE OF REPORT**

1. GZA GeoEnvironmental, Inc. (GZA) prepared this report on behalf of, and for the exclusive use of South Central Connecticut Regional Water Authority (Client) for the stated purpose(s) and location(s) identified in the Report. Use of this report, in whole or in part, at other locations, or for other purposes, may lead to inappropriate conclusions; and we do not accept any responsibility for the consequences of such use(s). Further, reliance by any party not identified in the agreement, for any use, without our prior written permission, shall be at that party's sole risk, and without any liability to GZA.

## **GENERAL**

2. The observations described in this report were made under the conditions stated therein. The conclusions presented were based solely upon the services described therein, and not on scientific tasks or procedures beyond the scope of described services or the time and budgetary constraints imposed by the Client.
3. In preparing this report, GZA relied on certain information provided by the Client, state and local officials, and other parties referenced therein available to GZA at the time of the evaluation. GZA did not attempt to independently verify the accuracy or completeness of all information reviewed or received during the course of this evaluation.
4. Observations were made of the site and of structures on the site as indicated within the report. Where access to portions of the structure or site, or to structures on the site was unavailable or limited, GZA renders no opinion as to the condition of that portion of the site or structure. In particular, it is noted that water levels in the impoundment and elsewhere and/or flow over the spillway may have limited GZA's ability to make observations of underwater portions of the structure. Excessive vegetation, when present, also inhibits observations.
5. In reviewing this Report, it should be realized that the reported condition of the dam is based on observations of field conditions during the course of this study along with data made available to GZA. It is important to note that the condition of a dam depends on numerous and constantly changing internal and external conditions, and is evolutionary in nature. It would be incorrect to assume that the present condition of the dam will continue to represent the condition of the dam at some point in the future. Only through continued inspection and care can there be any chance that unsafe conditions be detected.

## **STANDARD OF CARE**

6. Our findings and conclusions are based on the work conducted as part of the Scope of Services set forth in the Report and/or proposal, and reflect our professional judgment. These findings and conclusions must be considered not as scientific or engineering certainties, but rather as our professional opinions concerning the limited data gathered during the course of our work. Conditions other than described in this report may be found at the subject location(s).
7. Our services were performed using the degree of skill and care ordinarily exercised by qualified professionals performing the same type of services at the same time, under similar conditions, at the same or a similar property. No warranty, expressed or implied, is made.
8. The interpretations and conclusions presented in the Report were based solely upon the services described therein, and not on scientific tasks or procedures beyond the scope of the described services. The work described in this report was carried out in accordance with the agreed upon Terms and Conditions of Engagement.



## **FLOOD EVALUATION**

9. GZA's flood evaluation was performed in accordance with generally accepted practices of qualified professionals performing the same type of services at the same time, under similar conditions, at the same or a similar property. No warranty, expressed or implied, is made. The findings of the risk characterization are dependent on numerous assumptions and uncertainties inherent in the risk assessment process. The findings of the flood evaluation are not an absolute characterization of actual risks, but rather serve to highlight potential sources of risk at the site(s).
10. The study includes development of flood frequency curves. These curves were developed for the current climate and precipitation conditions. The development of flood-frequency curves relied on readably available historical storm data. Future storms that impact the project area may result in changes to the flood-frequency curves.
11. Unless specifically stated otherwise, the flood evaluations performed by GZA and associated results and conclusions are based upon evaluation of historic data, trends, references, and guidance with respect to the current climate and sea level conditions. Future climate change may result in alterations to inputs which influence flooding at the site (*e.g.* rainfall totals, storm intensities, mean sea level, *etc.*). Such changes may have implications on the estimated flood elevations, wave heights, flood frequencies and/or other parameters contained in this report.

## **SUBSURFACE CONDITIONS**

12. The sediment mapping and description, along with the conclusions and recommendations provided in our Report, are based in part on widely-spaced subsurface explorations by GZA and/or others, with a limited number of sediment samples and are intended only to convey trends in subsurface conditions. The boundaries between strata are approximate and idealized, and were based on our assessment of subsurface conditions. The composition of strata, and the transitions between strata, may be more variable and more complex than indicated. For more specific information on soil conditions at a specific location refer to the exploration logs. The nature and extent of variations between these explorations may not become evident until further exploration or construction. If variations or other latent conditions then appear evident, it will be necessary to reevaluate the conclusions and recommendations of this report.

## **COMPLIANCE WITH CODES AND REGULATIONS**

13. We used reasonable care in identifying and interpreting applicable codes and regulations. These codes and regulations are subject to various, and possibly contradictory, interpretations. Compliance with codes and regulations by other parties is beyond our control.
14. This scope of work does not include an assessment of the need for fences, gates, no-trespassing signs, repairs to existing fences and railings and other items which may be needed to minimize trespass and provide greater security for the facility and safety to the public. An evaluation of the project for compliance with OSHA rules and regulations is also excluded.

## **ADDITIONAL INFORMATION**

15. In the event that the Client or others authorized to use this report obtain information on conditions at the site(s) not contained in this report, such information shall be brought to GZA's attention forthwith. GZA will evaluate such information and, on the basis of this evaluation, may modify the opinions stated in this report.

## **ADDITIONAL SERVICES**

16. It is recommended that GZA be retained to provide services during any future: site observations, explorations, evaluations, design, implementation activities, construction and/or implementation of remedial measures



recommended in this Report. This will allow us the opportunity to: i) observe conditions and compliance with our design concepts and opinions; ii) allow for changes in the event that conditions are other than anticipated; iii) provide modifications to our design; and iv) assess the consequences of changes in technologies and/or regulations.



## **Appendix B – Key Terms**



Leading Edge Arrival Time: The leading edge arrival time of the flood wave is an important parameter for emergency notification and evacuation purposes. It describes the interval between the time when the dam failure first begins and the time when the flood wave starts to create a significant rise in river level at a particular location. The convention used to identify the time of leading edge is when water levels have risen 1 to 2 feet above initial (normal) stage. This parameter provides a “window” of time available for evacuation prior to commencement of significant out-of-bank flooding and enables emergency personnel to plan notification and evacuation procedures and priorities.

Peak Flood Arrival Time: The peak flood arrival time is the duration between initial dam failure and maximum water surface elevation at a particular location along the river. This provides emergency planners an estimate of how long it will take flood levels to reach their peak. This time, in most cases, is much longer than the arrival time of the leading edge.

Maximum Water Surface Elevation: The maximum water surface elevation is defined as the maximum stage that the flood wave reaches as it progresses downstream. Emergency management personnel can utilize the elevations to determine high ground and important impact areas in their respective towns. Note that the contours shown on the inundation maps are in feet in the NAVD 88 datum.

Peak Discharge: The peak discharge, expressed in cubic feet per second (cfs), is the maximum flow through a particular reach (section) of the river. Peak discharges resulting from a dam break situation would typically exceed any previous maximum flows experienced in a river valley. The values are useful in estimating the flow velocities and evaluating potential impacts in heavily populated or industrial areas, especially along riverbanks. However, for practical purposes, the discharge value is not as useful for public safety personnel as are the data on arrival times and maximum stage.

Incremental Increase in Water Surface Elevation: The difference in maximum water surface elevation with and without dam failure under fair weather or wet weather conditions.





## **Appendix C - HEC-HMS Calibration and verification**



Subbasin "Gauging Station" Results for Run "June 1992"

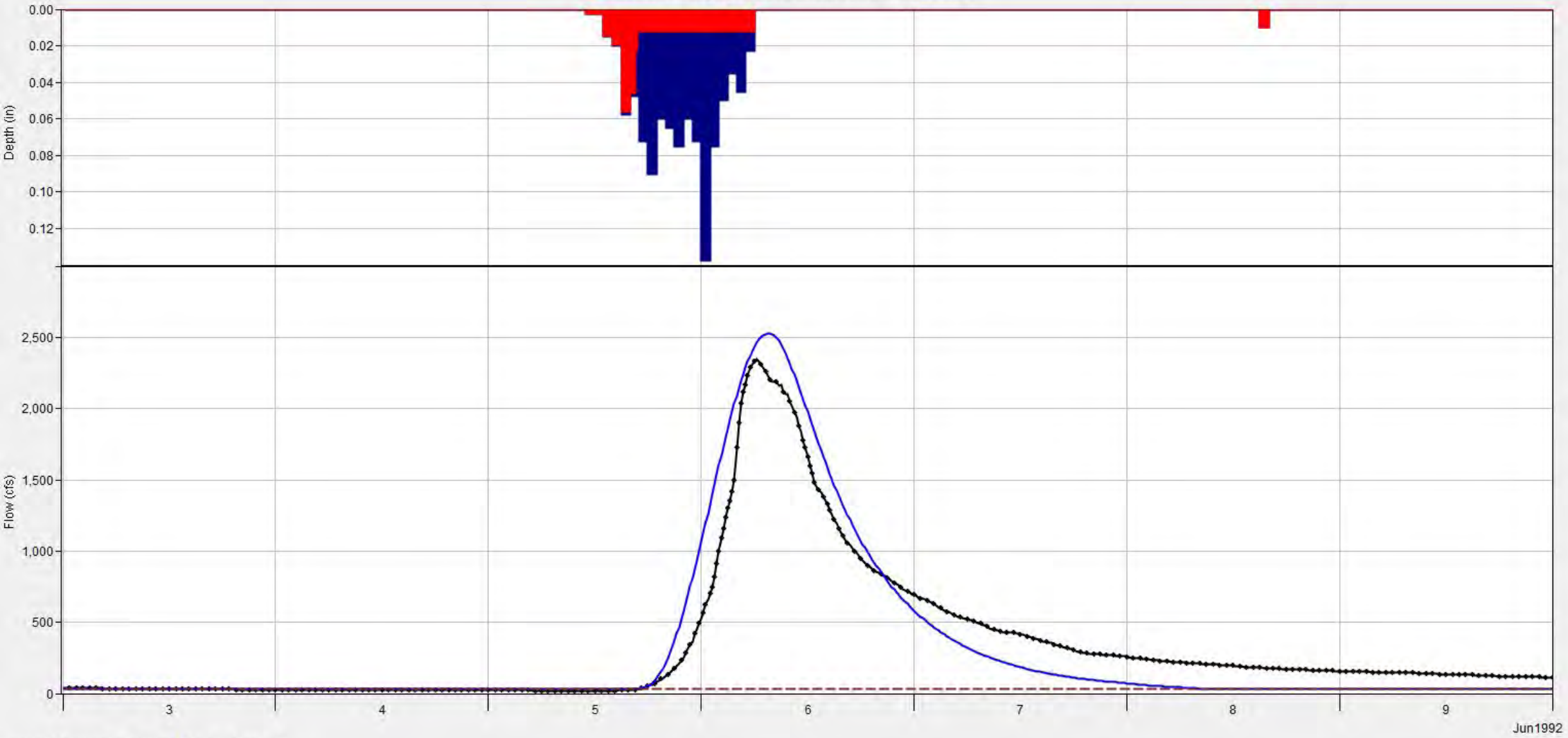

Legend (Compute Time: 03Jul2019, 12:29:51)

- █ Run: June 1992 Element: Gauging Station Result: Precipitation
- █ Run: June 1992 Element: Gauging Station Result: Precipitation Loss
- Run: June 1992 Element: Gauging Station Result: Observed Flow
- Run: June 1992 Element: Gauging Station Result: Outflow
- - - Run: June 1992 Element: Gauging Station Result: Baseflow

Subbasin "Gauging Station" Results for Run "April 2007"

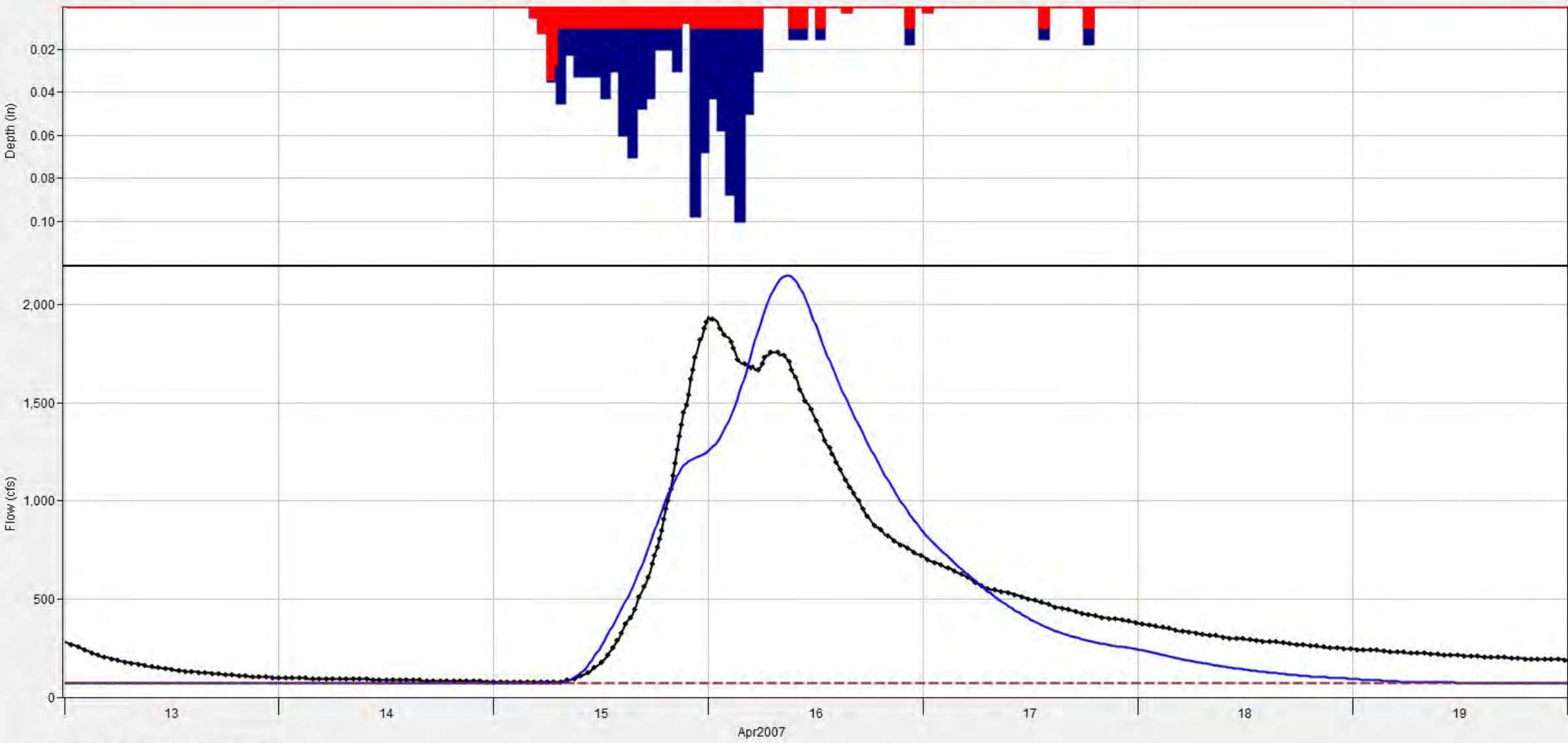

Legend (Compute Time: 03Jul2019, 13:34:24)

- Run:April 2007 Element:Gauging Station Result:Precipitation
- Run:April 2007 Element:Gauging Station Result:Precipitation Loss
- Run:April 2007 Element:Gauging Station Result:Observed Flow
- Run:April 2007 Element:Gauging Station Result:Outflow
- Run:April 2007 Element:Gauging Station Result:Baseflow

Subbasin "Gauging Station" Results for Run "April 2006"

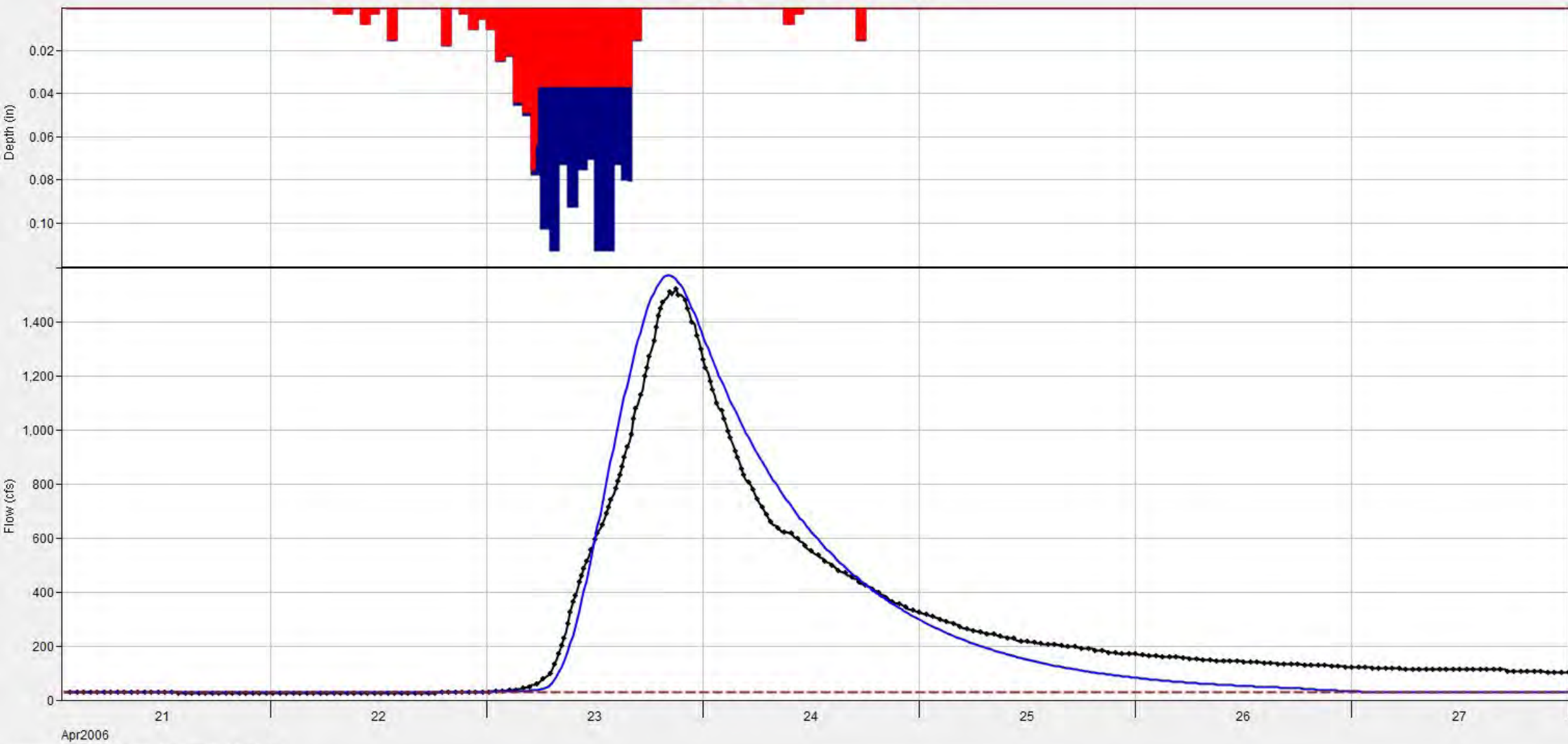

Legend (Compute Time: 03Jul2019, 13:39:55)

- Run:April 2006 Element:Gauging Station Result:Precipitation
- Run:April 2006 Element:Gauging Station Result:Precipitation Loss
- Run:April 2006 Element:Gauging Station Result:Observed Flow
- Run:April 2006 Element:Gauging Station Result:Outflow
- Run:April 2006 Element:Gauging Station Result:Baseflow

Subbasin "Gauging Station" Results for Run "June 1982"

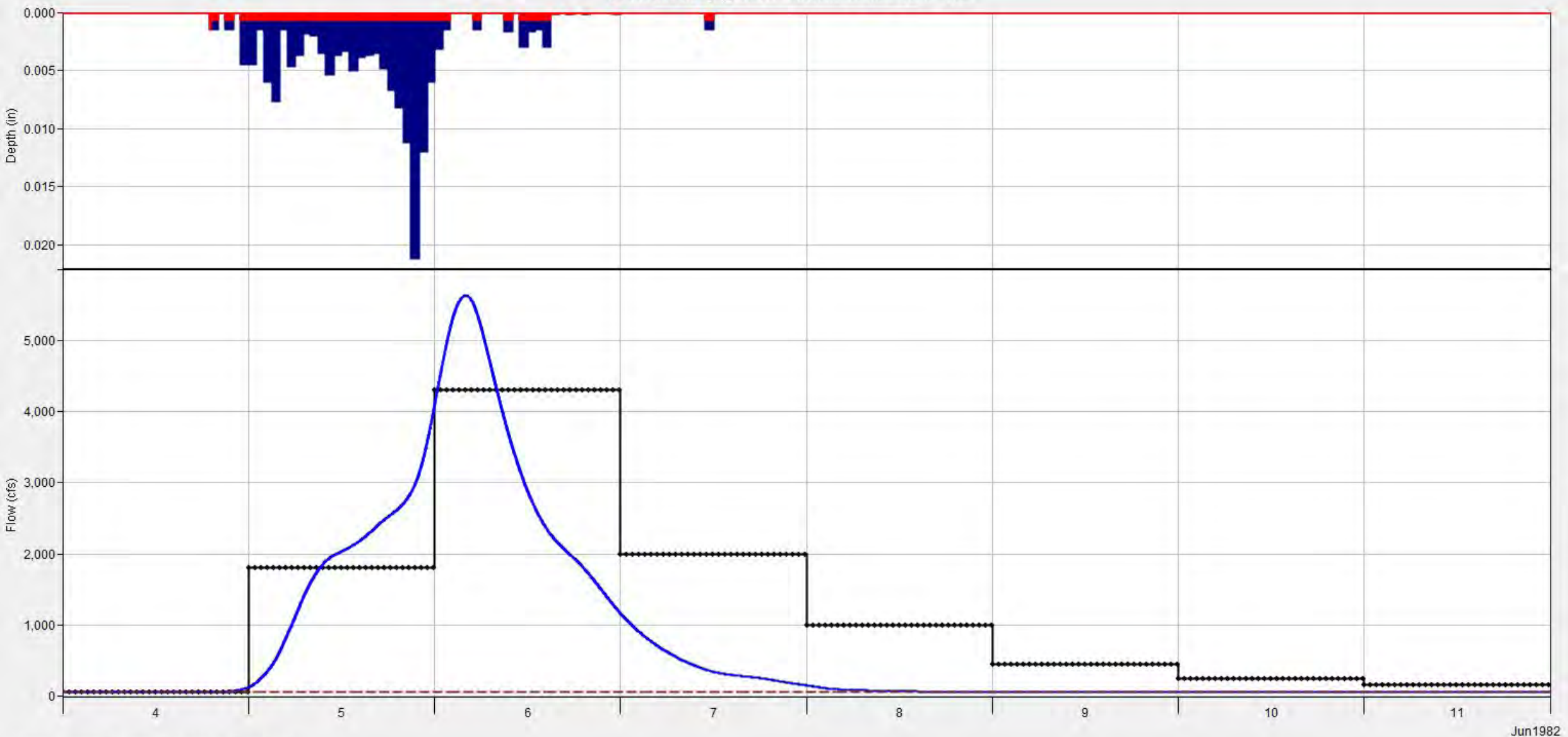

Jun1982

Legend (Compute Time: 06Aug2019, 09:05:57)

- █ Run:June 1982 Element:Gauging Station Result:Precipitation
- █ Run:June 1982 Element:Gauging Station Result:Precipitation Loss
- Run:June 1982 Element:Gauging Station Result:Observed Flow
- Run:June 1982 Element:Gauging Station Result:Outflow
- - - Run:June 1982 Element:Gauging Station Result:Baseflow

Subbasin "Gauging Station" Results for Run "April 1996"

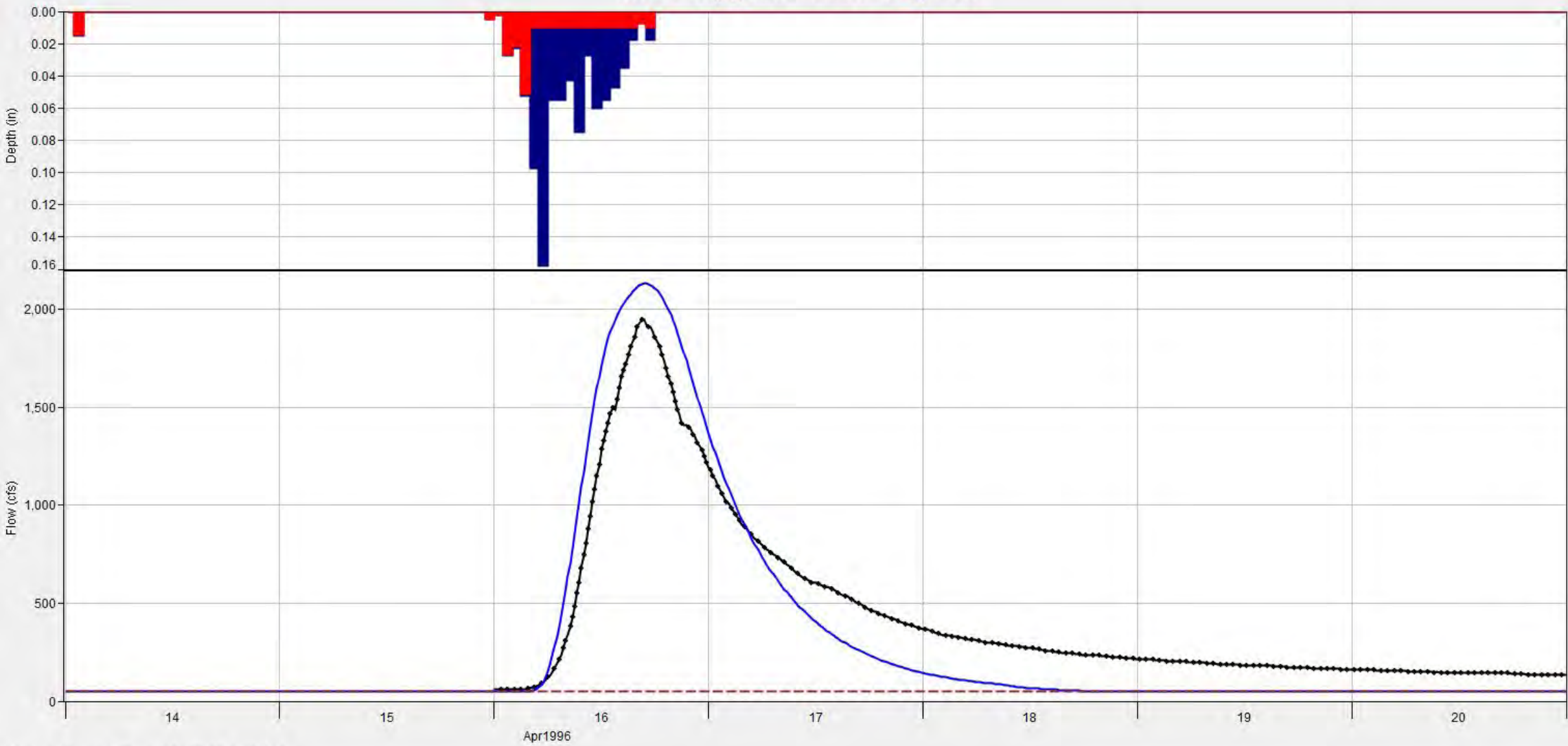

Legend (Compute Time: 19Jul2019, 11:42:26)

- Run:April 1996 Element:Gauging Station Result:Precipitation
- Run:April 1996 Element:Gauging Station Result:Precipitation Loss
- Run:April 1996 Element:Gauging Station Result:Observed Flow
- Run:April 1996 Element:Gauging Station Result:Outflow
- Run:April 1996 Element:Gauging Station Result:Baseflow



## **Appendix D – Probable Maximum Flood Inflow Hydrograph**



**HMR52 Standard Isohyetal Pattern and Storm Orientation for Lake Whitney Dam Catchment**

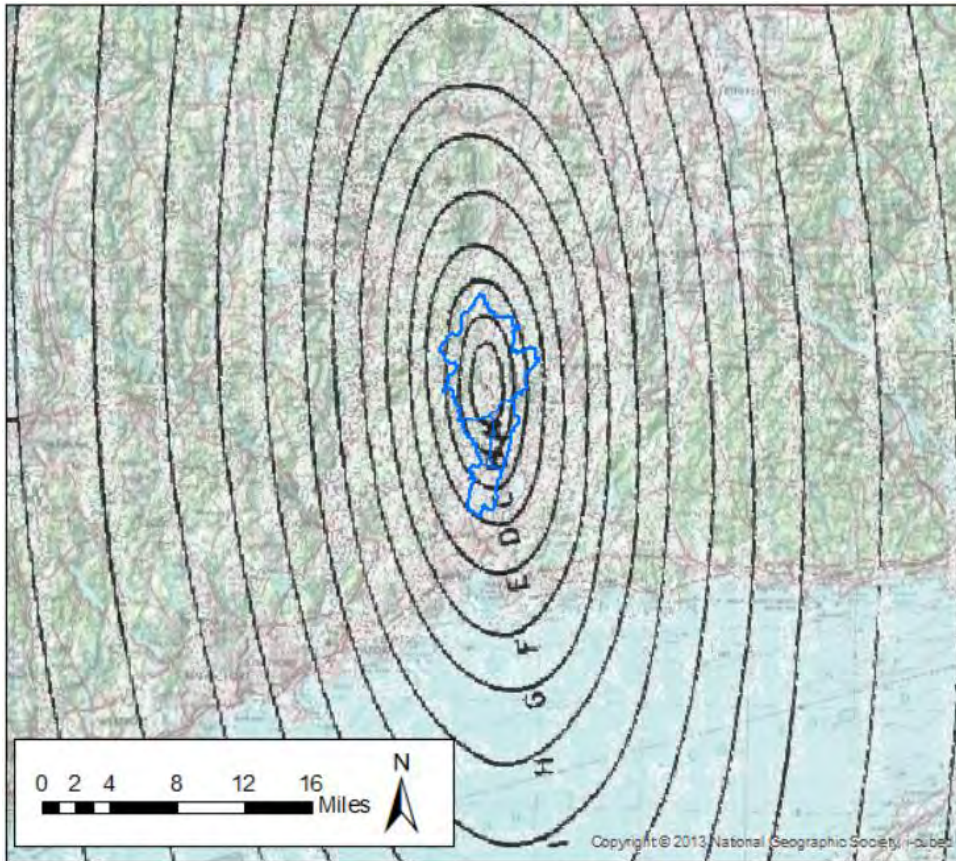

Isohyet	A	B	C	D	E	F	G	H	I
Area (mi <sup>2</sup> )	10	25	50	100	175	300	450	700	1,000

**PMP Duration Precipitation Function (inches) at Lake Whitney Dam Catchment**

Hr \ mi <sup>2</sup>	10	200	1,000	5,000	10,000	20,000
6	26.0	17.6	12.4	7.6	6.0	4.2
12	30.0	20.9	15.9	11.1	9.3	7.3
24	32.9	24.2	19.7	14.0	11.8	9.7
48	36.9	27.8	23.1	17.6	14.7	13.0
72	38.2	29.0	23.7	18.3	16.0	14.0



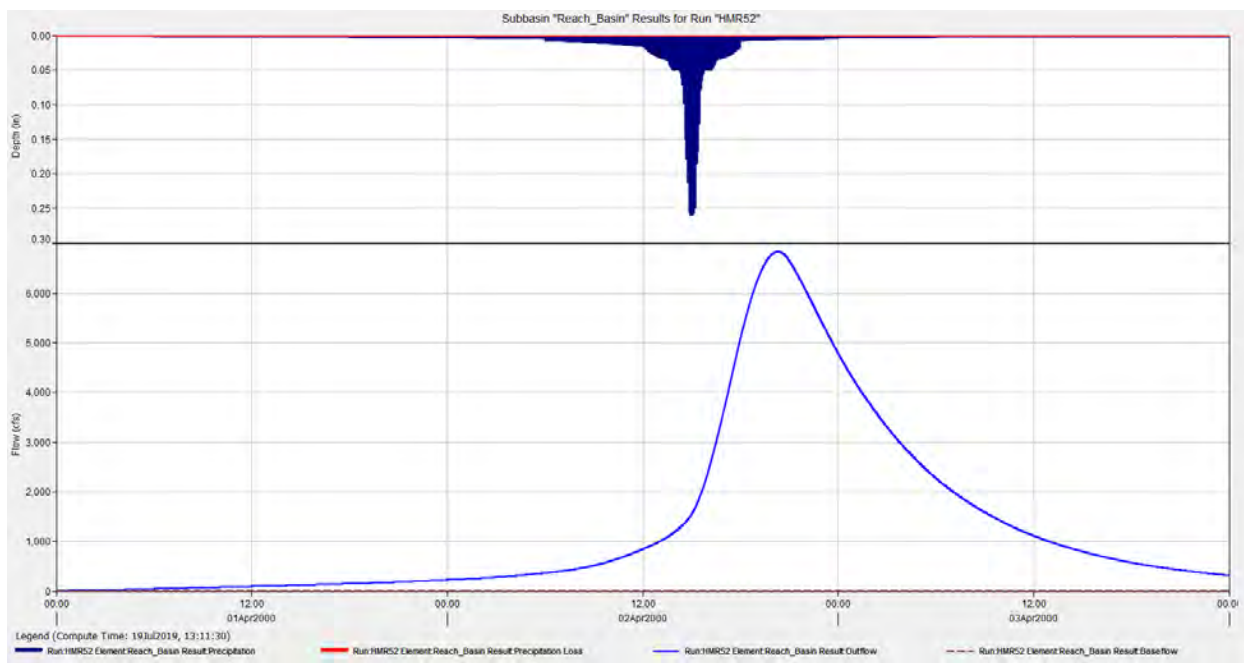
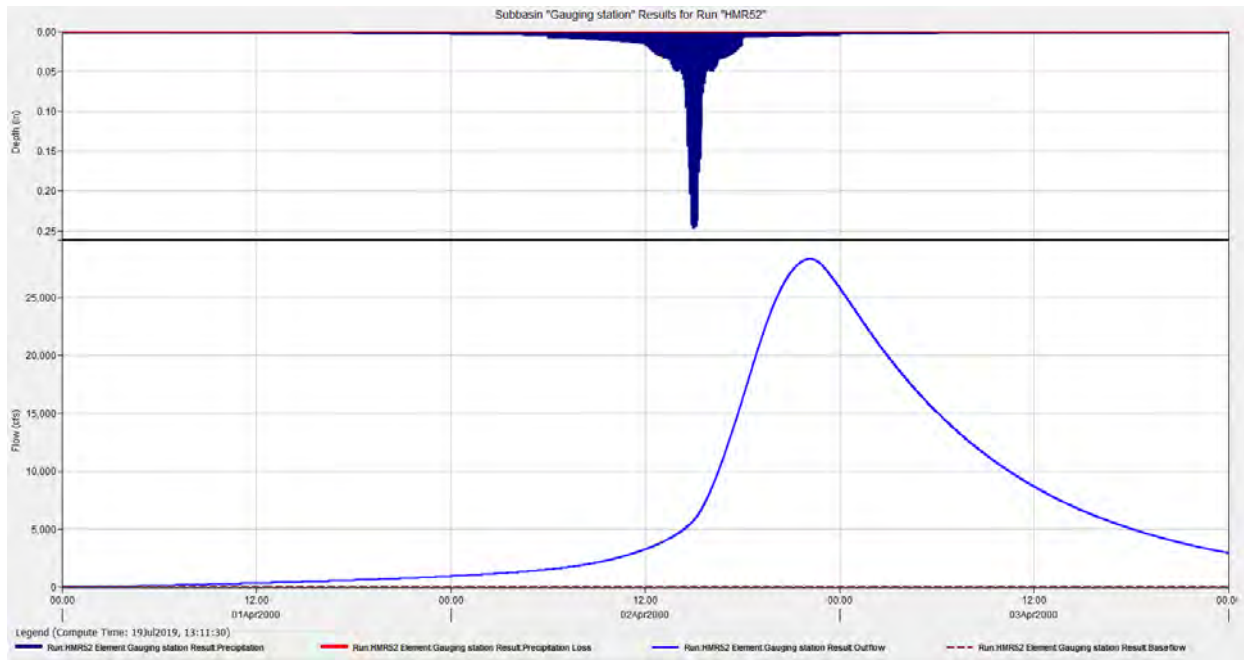

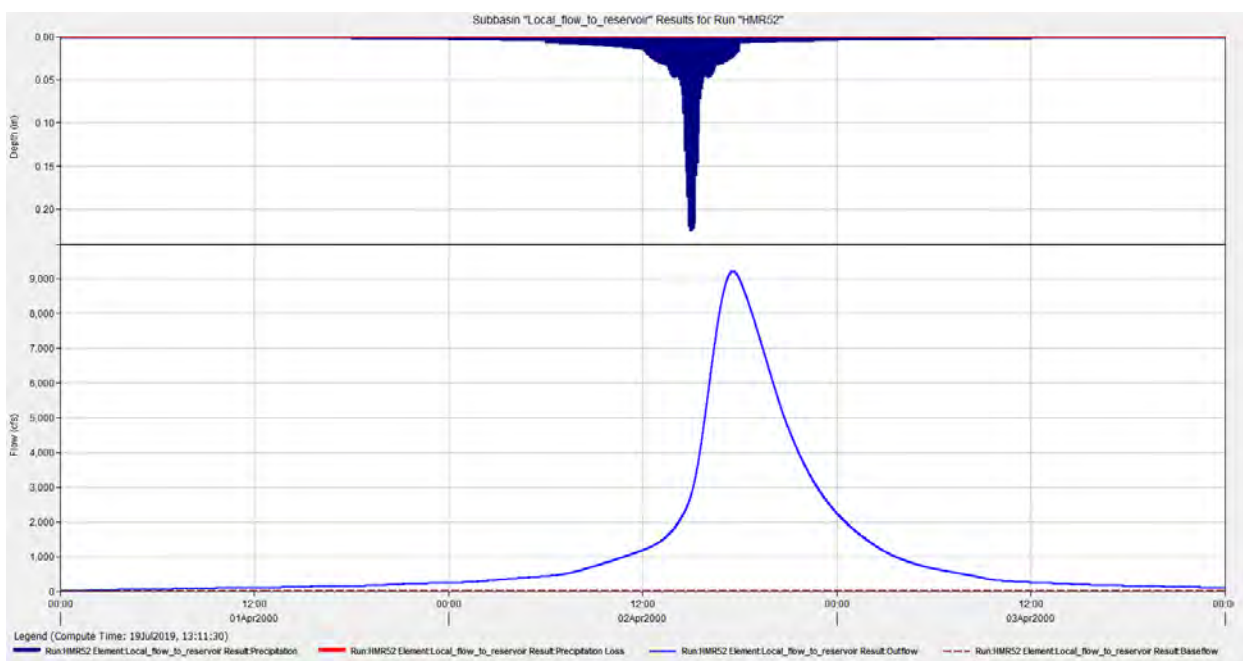
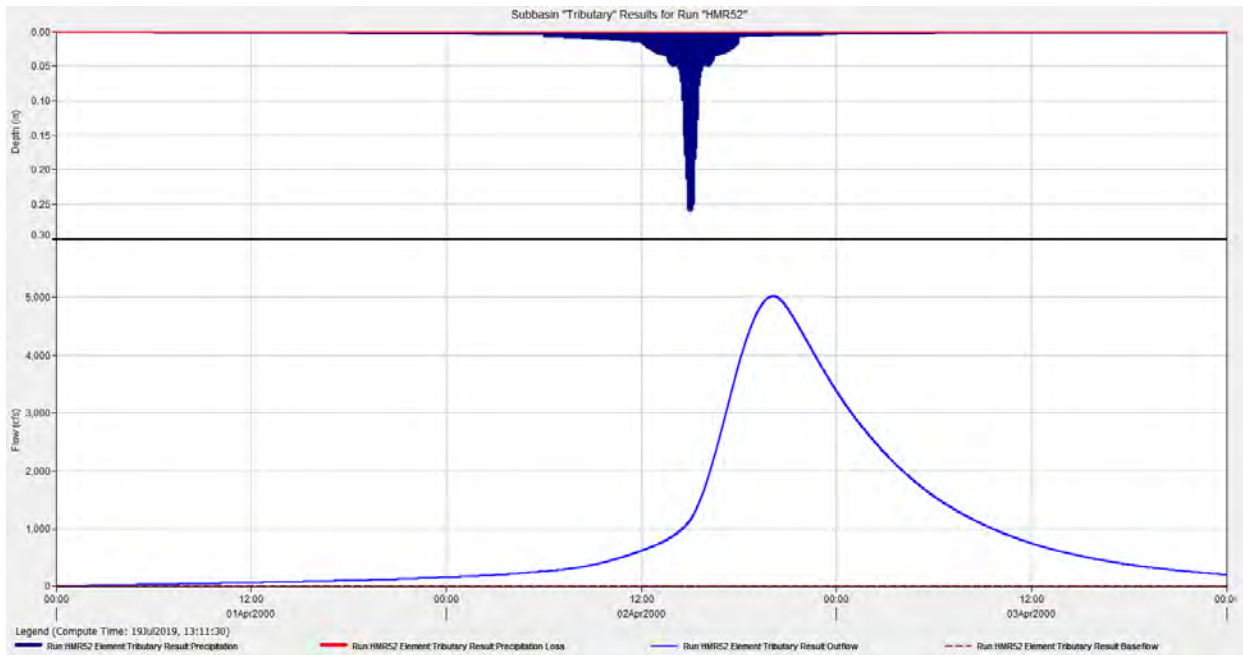

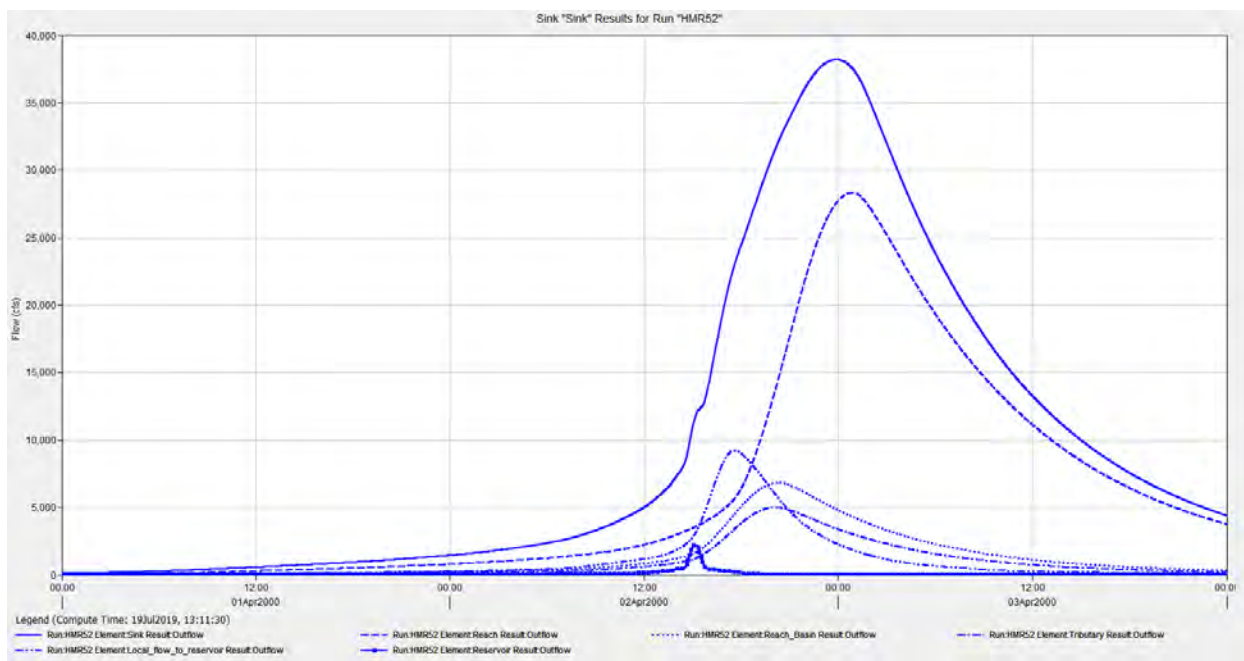
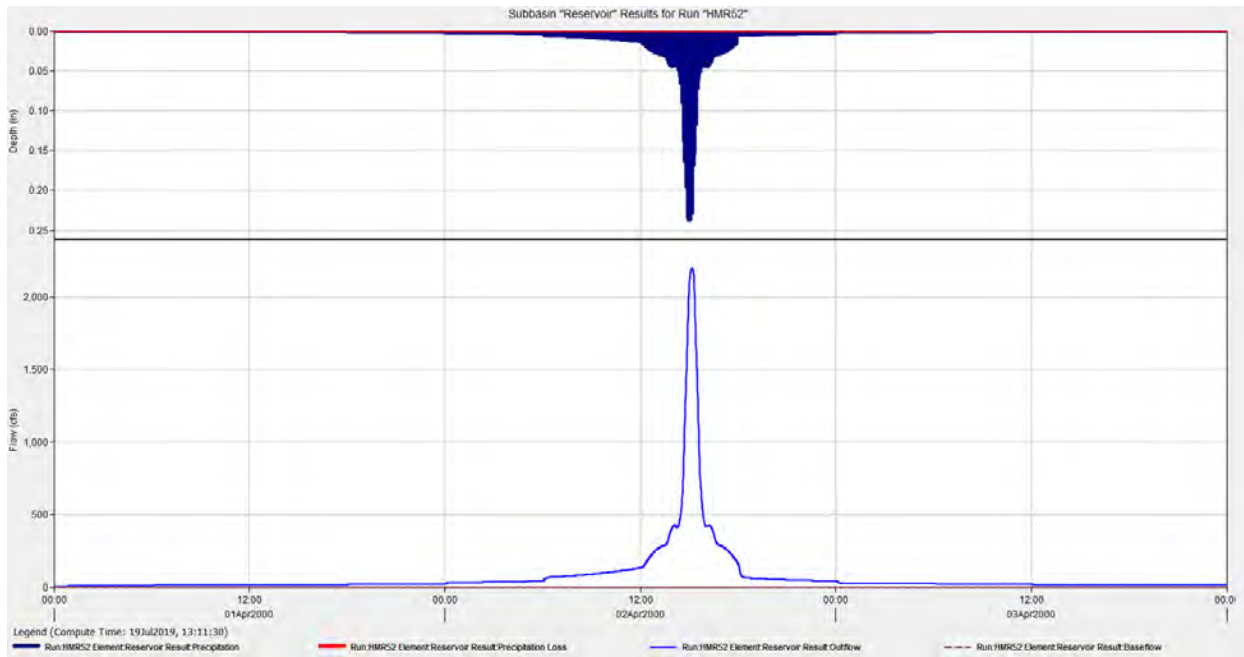

Plan: PMF existing geometry detailed crest SA Connection: Dam Crest

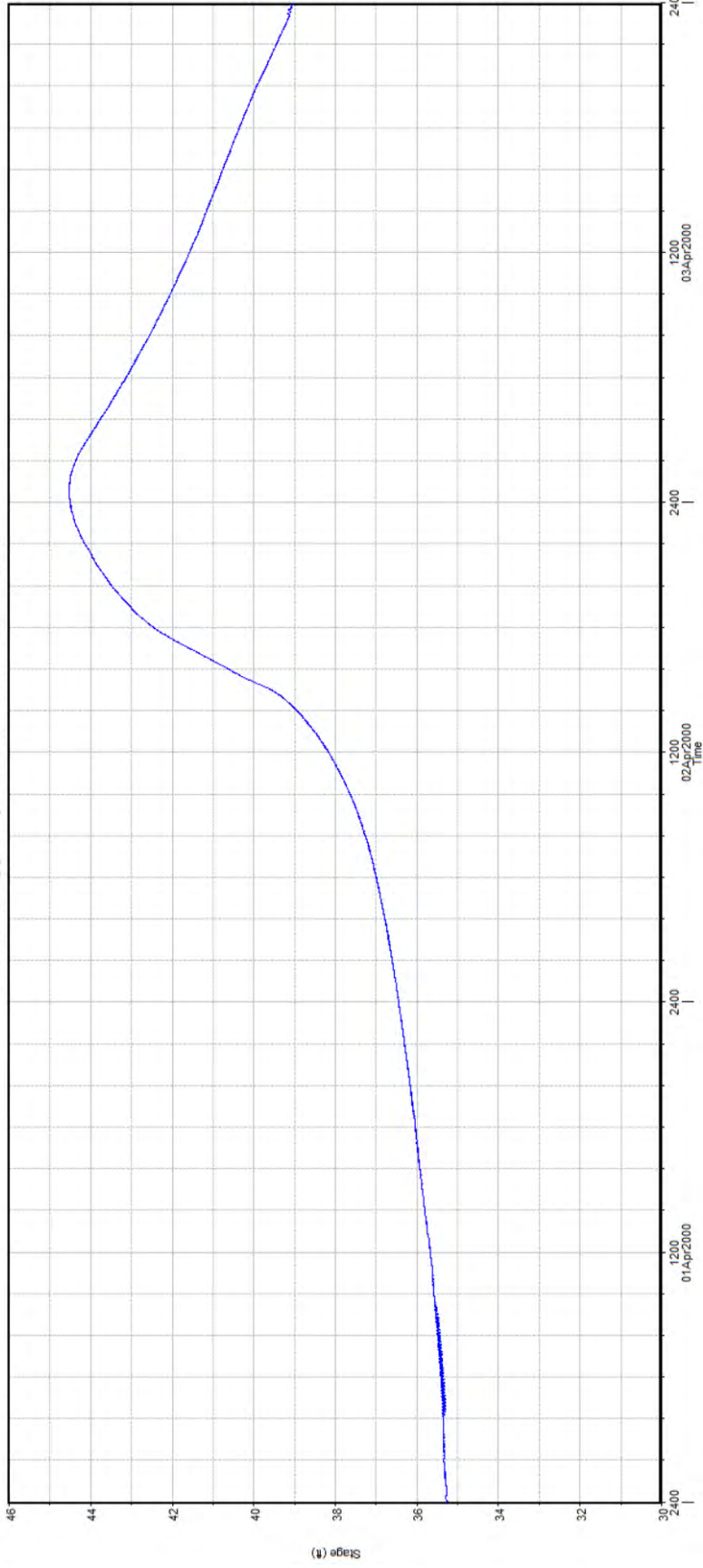

Results of PMF routing in HEC-RAS: Water Surface Elevation at the Dam Crest During PMF



## **Appendix E – Lake Whitney Dam HEC-RAS model extents**

Meshed Area: 2D Flow. Red Lines: Upstream and Downstream Boundary Condition. Blue Lines: Break-lines. Grey Lines: Structures

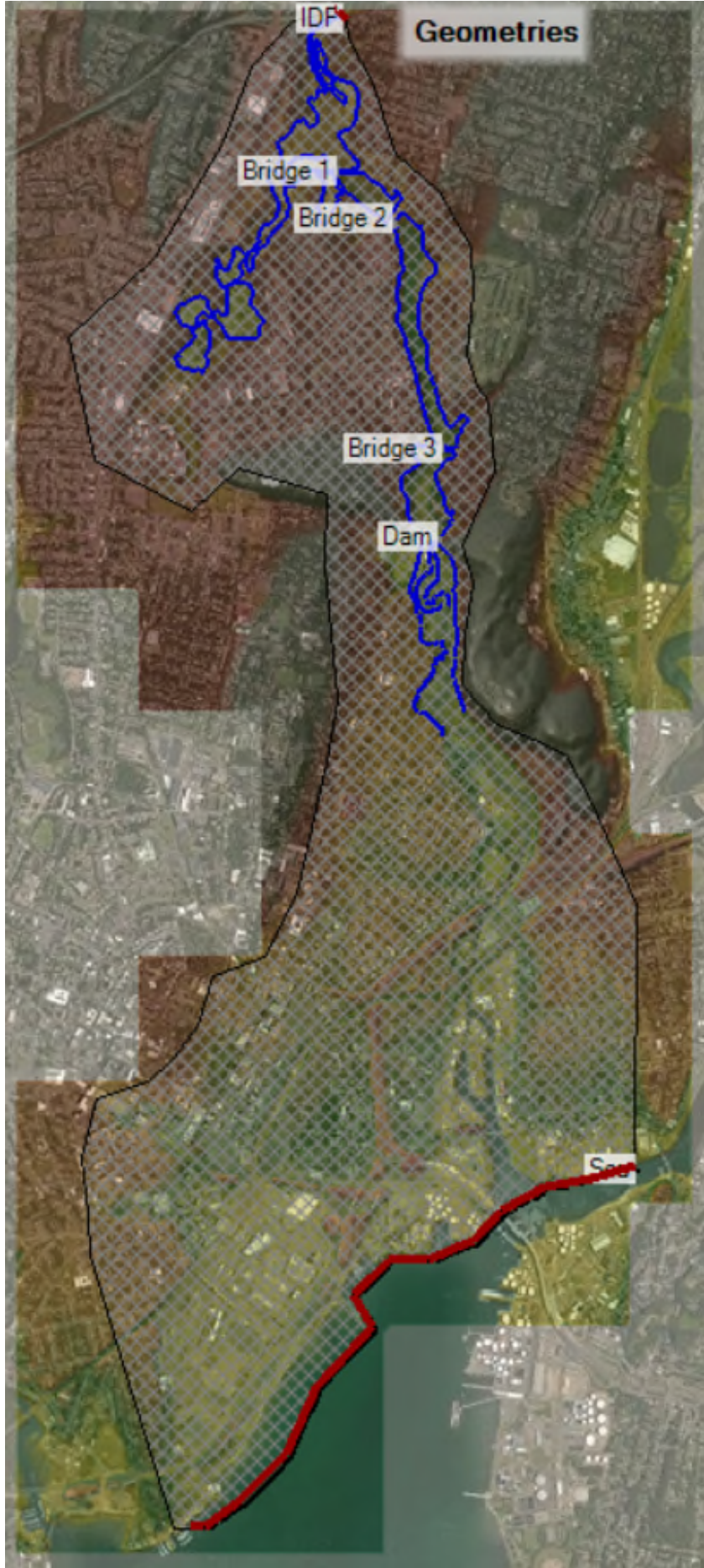





## **Appendix F – HEC-RAS Output Summaries**

Max water depth resulting from Dam break during PMF

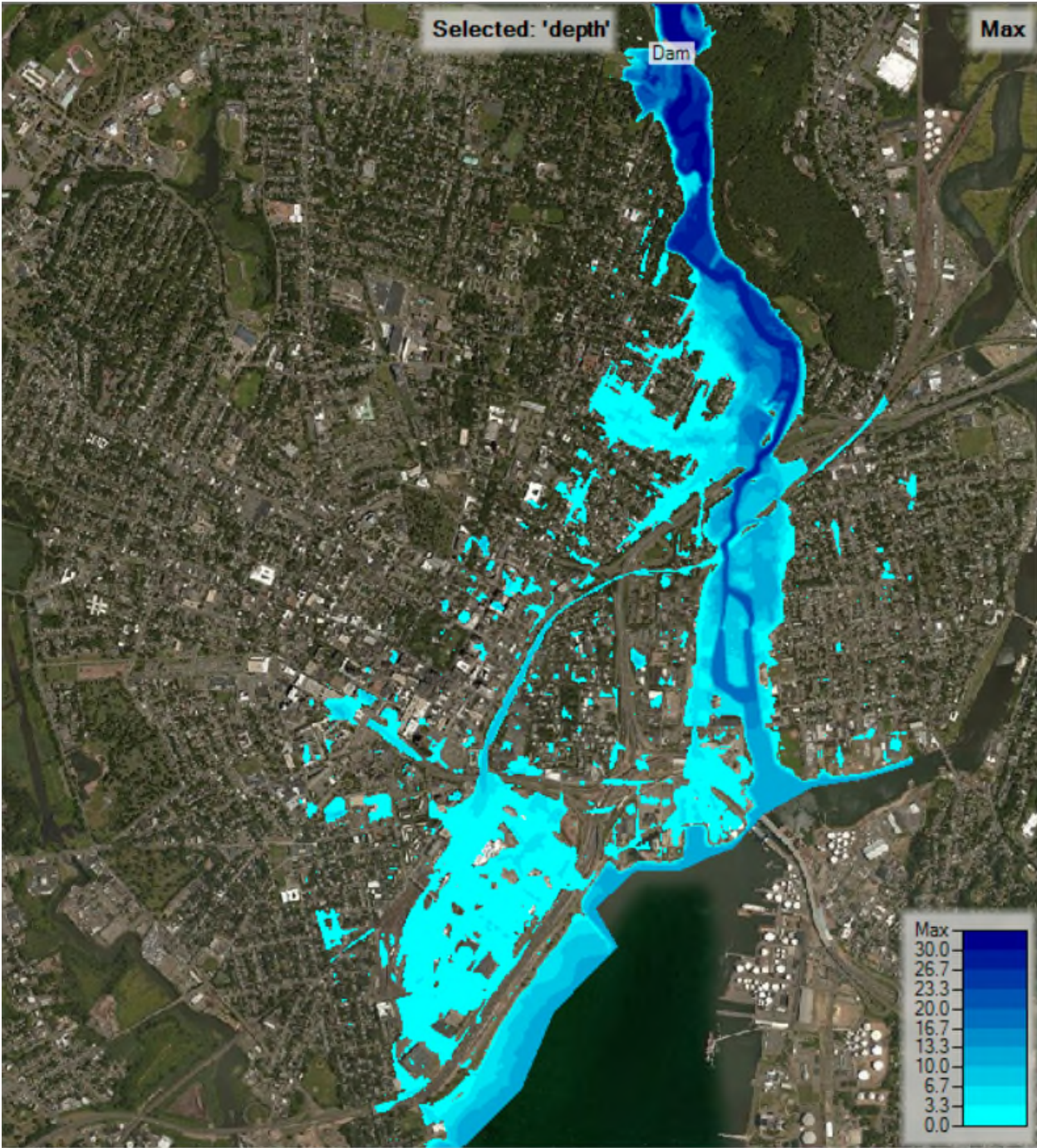

Max Depth times Velocity resulting from Dam break during PMF

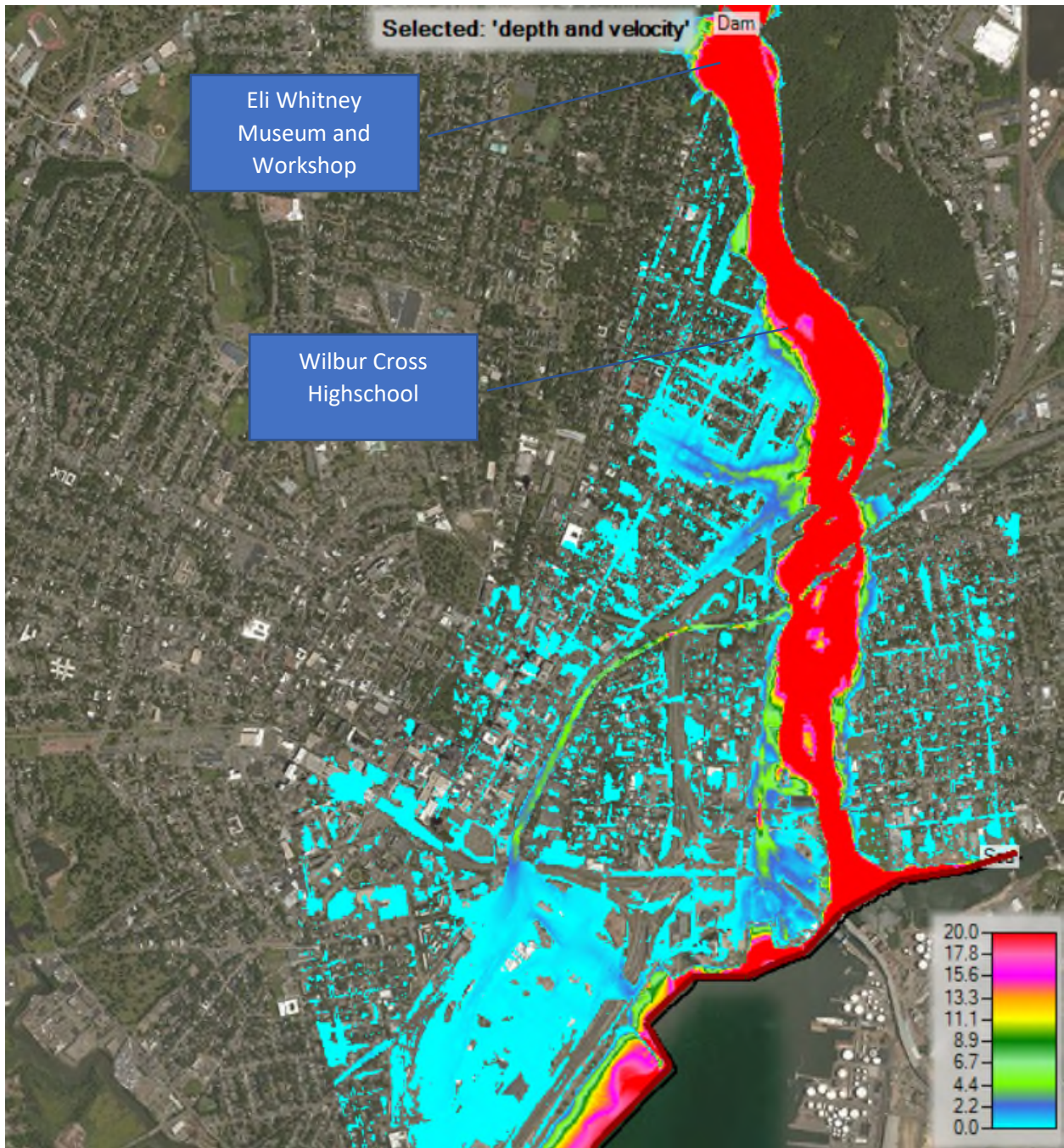

Max water depth during PMF

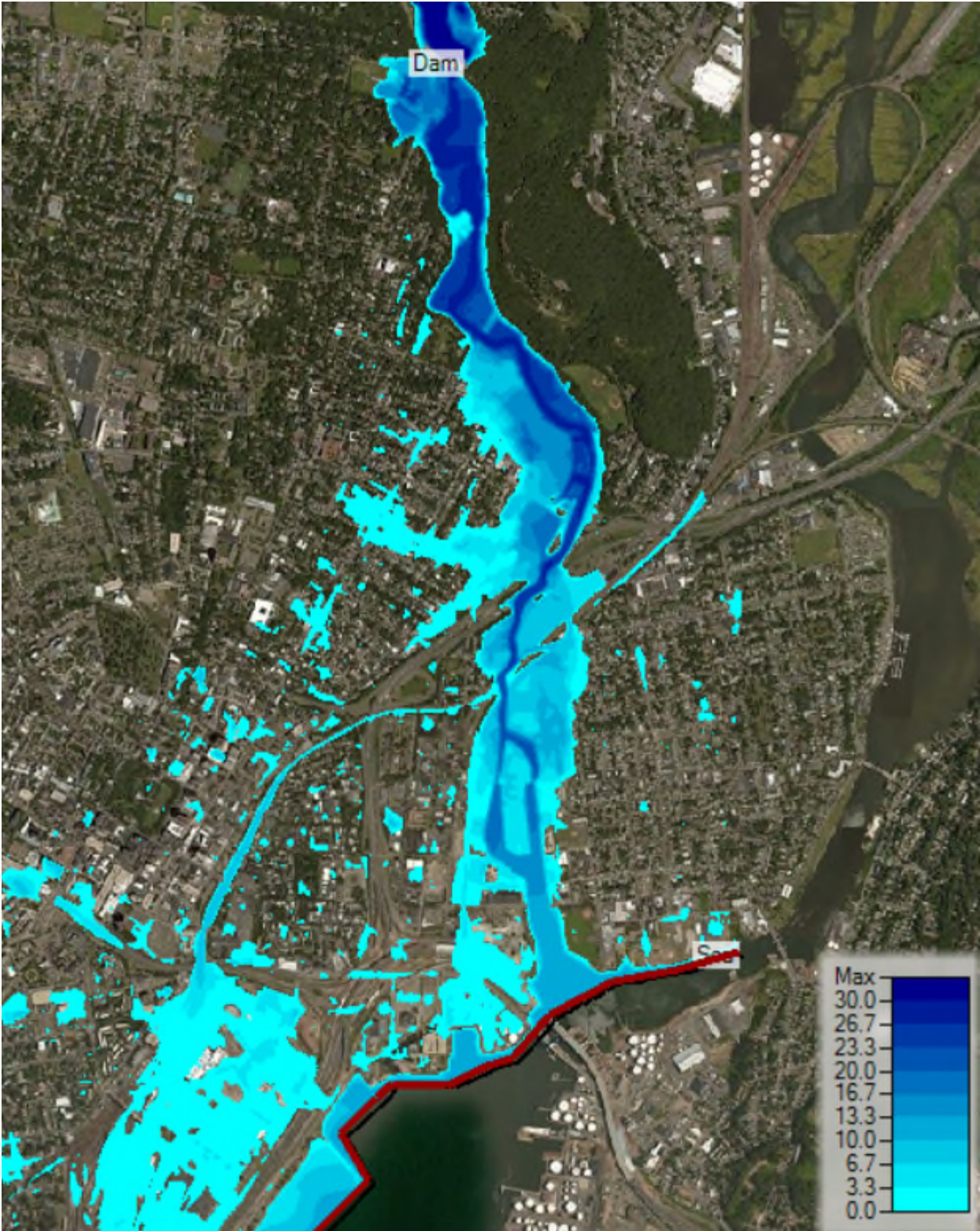

Max Depth times Velocity during PMF

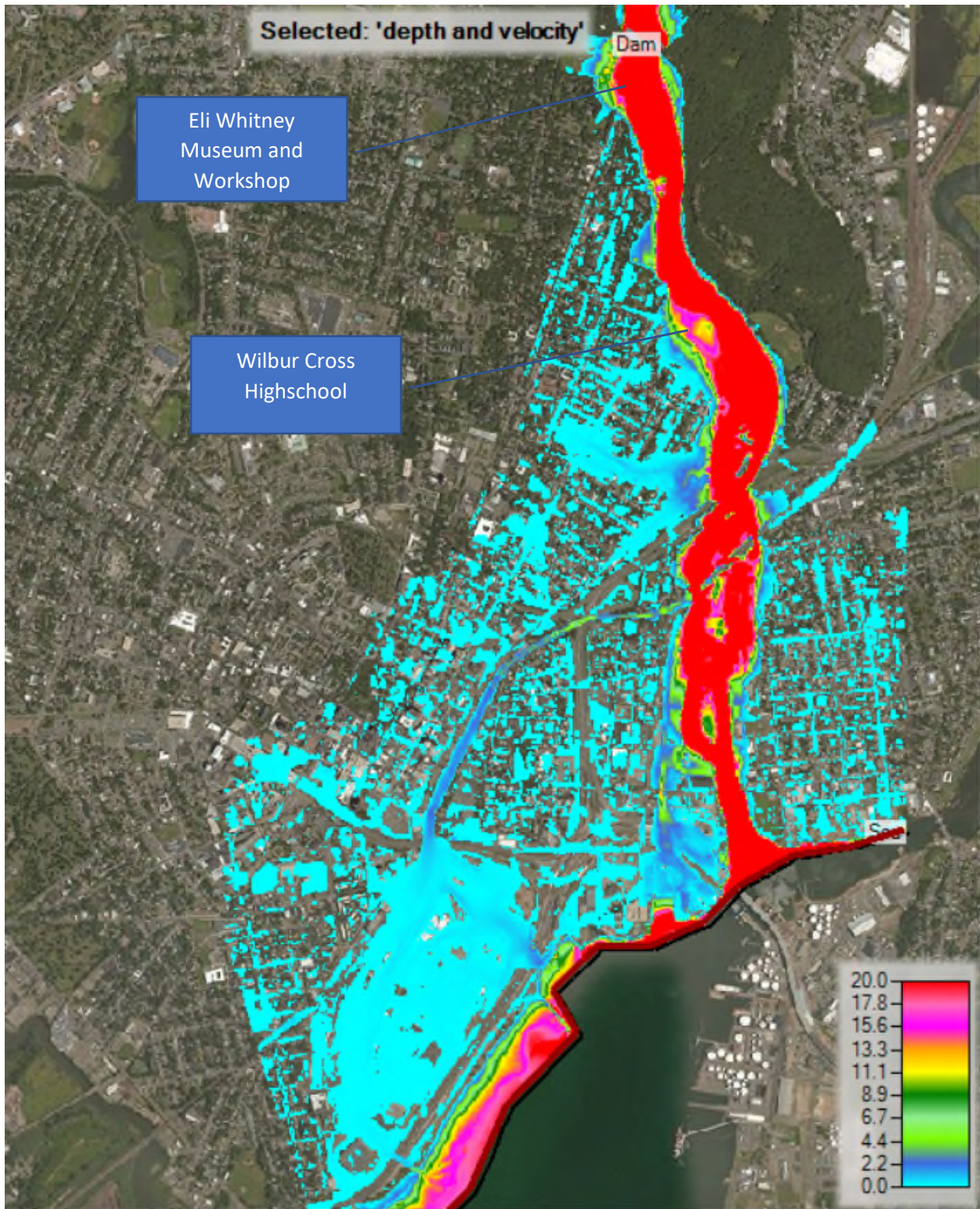

PMF Outflow from the dam, with and without Dam

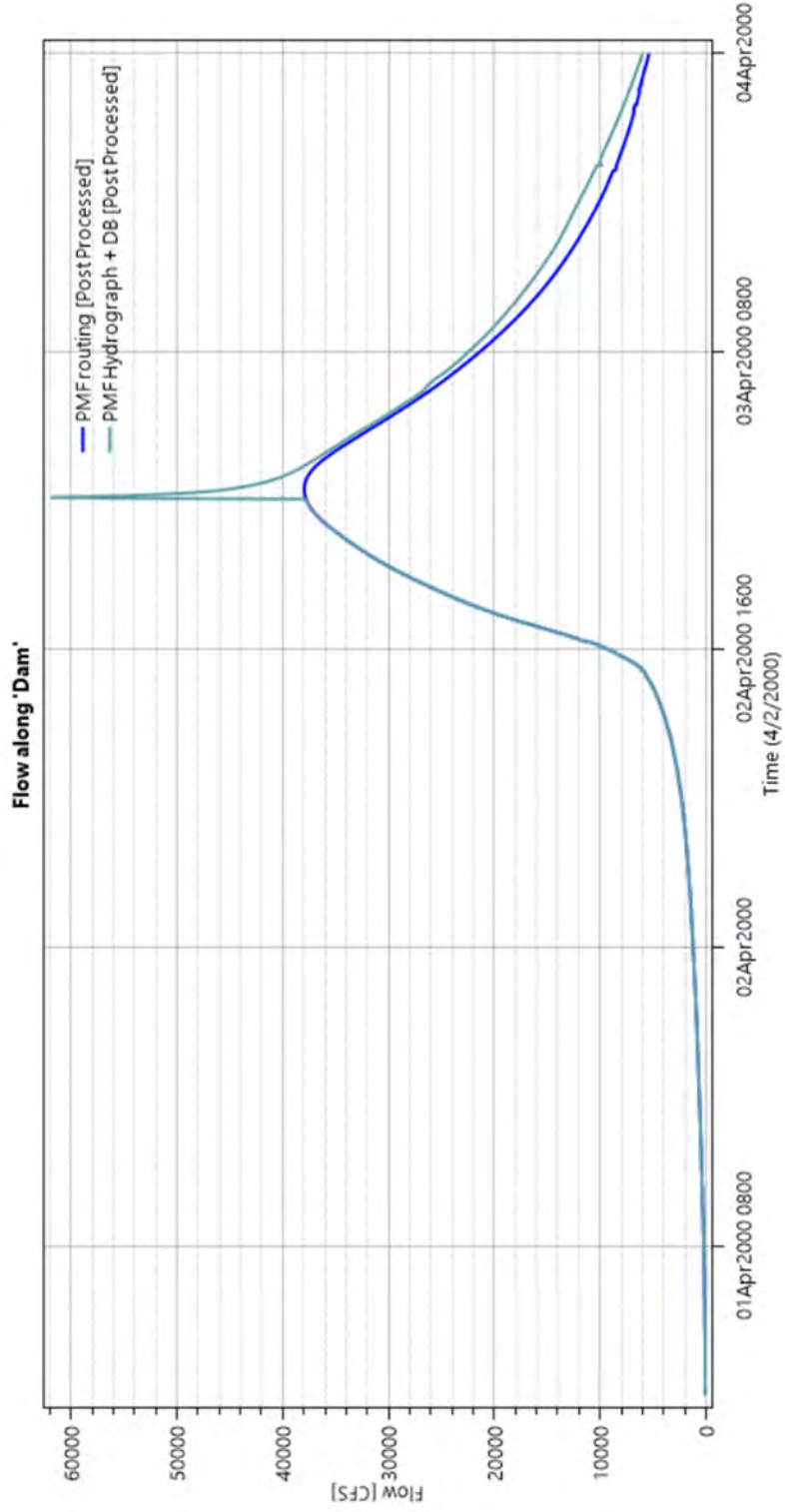



## **Appendix G – Inundation Maps**

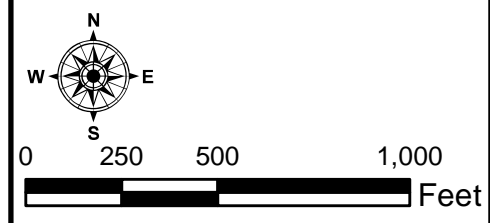
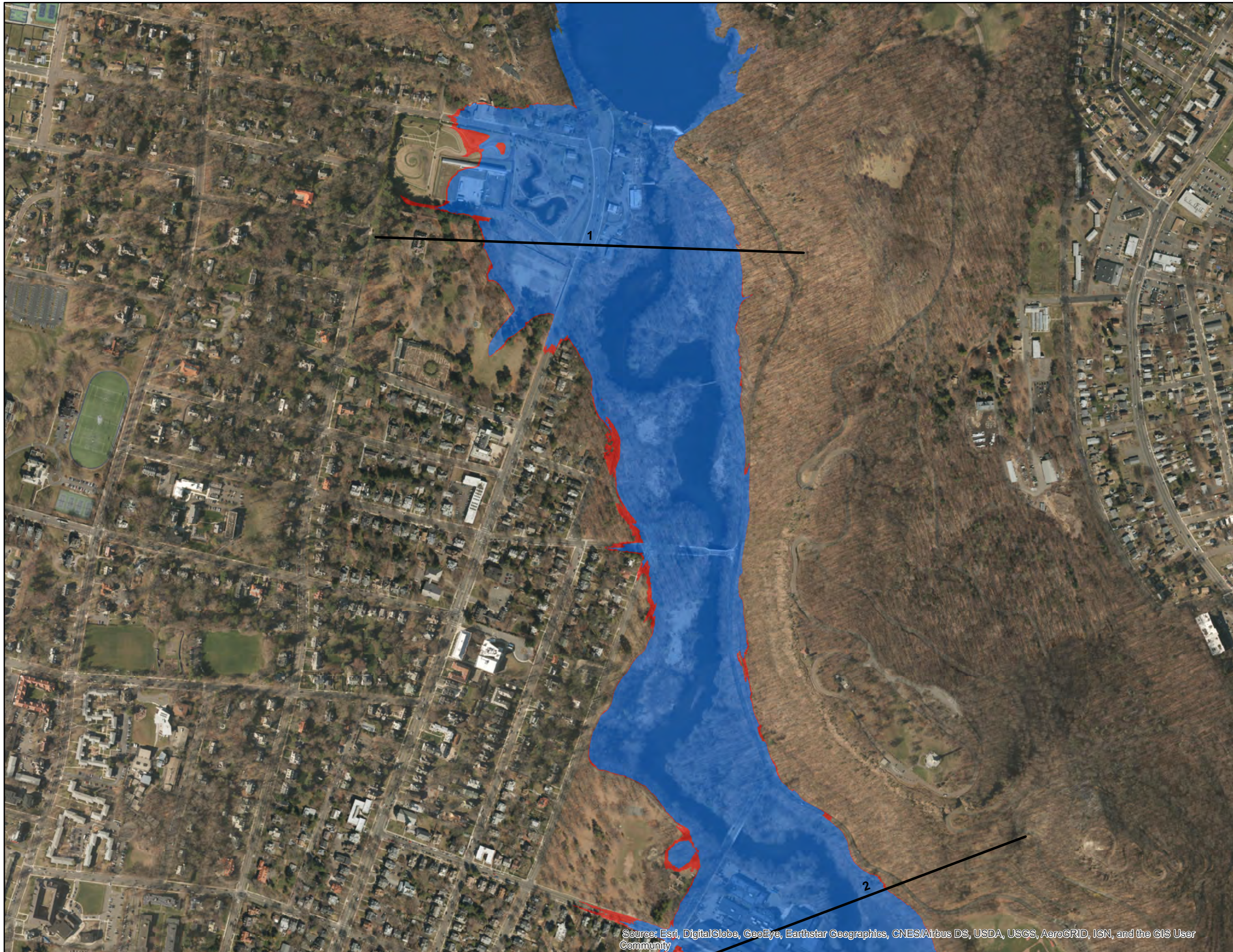

- Legend**
- Locations verified in ICA
  - PMF Flood
  - Dam Break During PMF Flood

NOTES:  
 1. DATUM IS NAVD 88.  
 2. AERIAL PHOTO FROM ESRI WORLD IMAGERY BASEMAP.

# LAKE WHITNEY DAM

NID ID: CT00119

New Haven, CT

## INUNDATION MAPPING FROM DAM FAILURE

Inundation Map 1 of 3

Prepared By:  
**GZA GeoEnvironmental, Inc.**   
 249 Vanderbilt Ave  
 Norwood, MA 02062  
 Phone: (781) 278-3700 Fax: (781) 278-5701



Proj. Mgr.: TEM	Dwg. Date: 8/6/2019
Designed By: MS	
Reviewed By: DML	
Operator:	Job No.: 01.0174183.00

Source: Esri, DigitalGlobe, GeoEye, Earthstar Geographics, CNES/Airbus DS, USDA, USGS, AeroGRID, IGN, and the GIS User Community

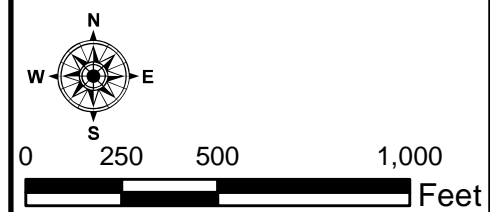
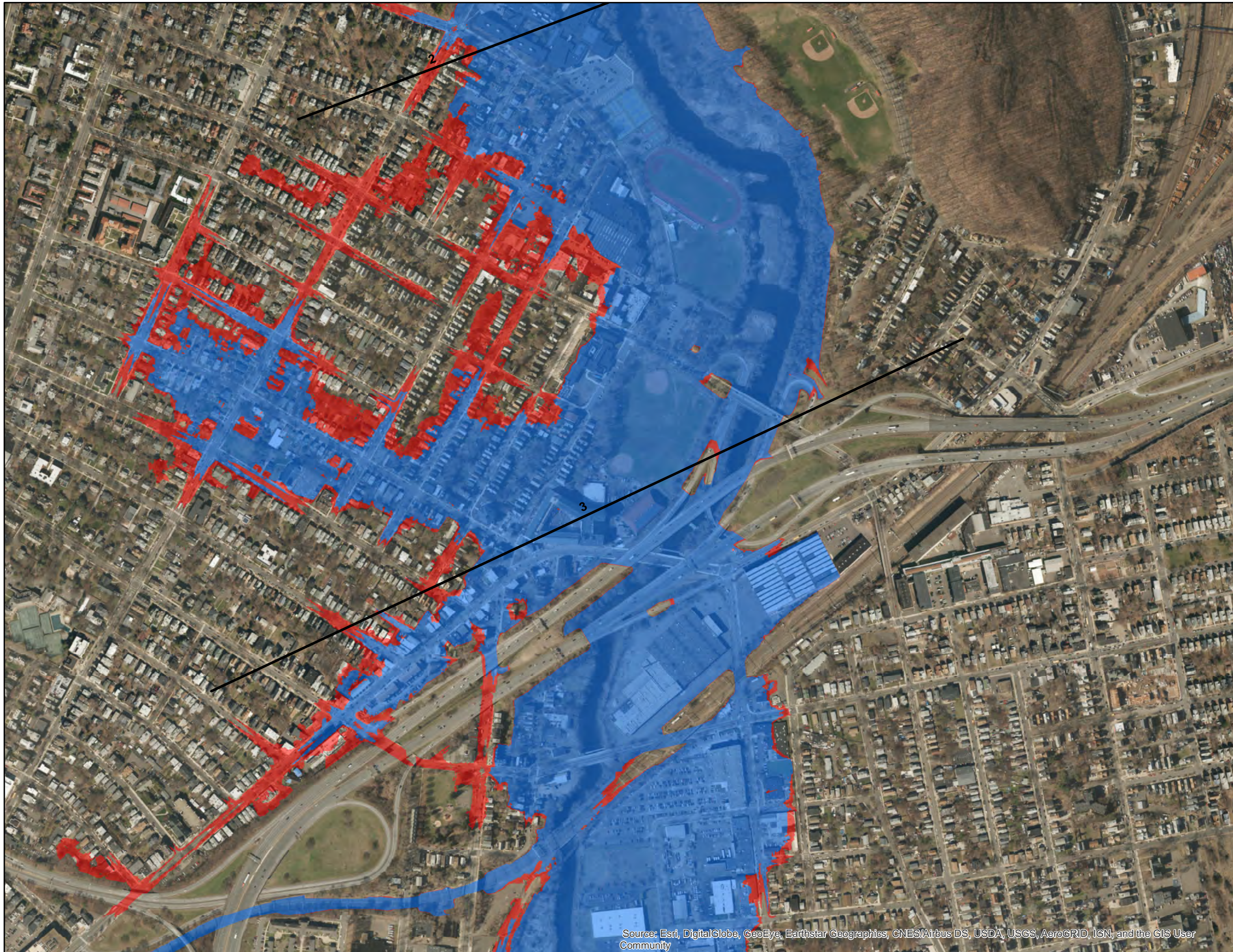

© 2019 - GZA GeoEnvironmental, Inc., J1170.000-179.9991741685-00.TEMFIGURES\GIS\REPORT\Inundation Map Dam Break PMF part 2.mxd, 8/6/2019, 9:13:31 AM, Media.Sehatzadeh



- Legend**
-  Locations verified in ICA
  -  PMF Flood
  -  Dam Break During PMF Flood

**NOTES:**  
 1. DATUM IS NAVD 88.  
 2. AERIAL PHOTO FROM ESRI WORLD IMAGERY BASEMAP.

# LAKE WHITNEY DAM

NID ID: CT00119

New Haven, CT

## INUNDATION MAPPING FROM DAM FAILURE

Inundation Map 2 of 3



Prepared By:  
 GZA GeoEnvironmental, Inc.   
 249 Vanderbilt Ave  
 Norwood, MA 02062  
 Phone: (781) 278-3700 Fax: (781) 278-5701

Proj. Mgr.: TEM	Dwg. Date: 8/6/2019
Designed By: MS	
Reviewed By: DML	
Operator:	Job No.: 01.0174183.00

Source: Esri, DigitalGlobe, GeoEye, Earthstar Geographics, CNES/Airbus DS, USDA, USGS, AeroGRID, IGN, and the GIS User Community

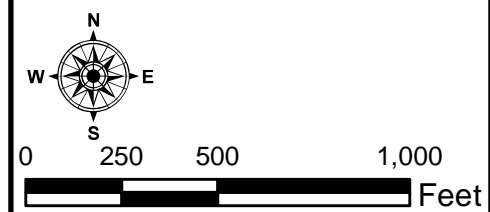
© 2019 - GZA GeoEnvironmental, Inc., J1170.000-179.999174183-00.TEMFIGURES\GIS\REPORT\Inundation Map Dam Break PMF part 3.mxd, 8/6/2019, 9:10:51 AM, Media.Sehatazadeh



- Legend**
-  Locations verified in ICA
  -  PMF Flood
  -  Dam Break During PMF Flood

NOTES:  
 1. DATUM IS NAVD 88.  
 2. AERIAL PHOTO FROM ESRI WORLD IMAGERY BASEMAP.

# LAKE WHITNEY DAM

NID ID: CT00119

New Haven, CT

## INUNDATION MAPPING FROM DAM FAILURE

Inundation Map 3 of 3

Prepared By:  
 GZA GeoEnvironmental, Inc.   
 249 Vanderbilt Ave  
 Norwood, MA 02062  
 Phone: (781) 278-3700 Fax: (781) 278-5701

Proj. Mgr.: TEM	Dwg. Date: 8/6/2019
Designed By: MS	
Reviewed By: DML	
Operator:	Job No.: 01.0174183.00

Source: Esri, DigitalGlobe, GeoEye, Earthstar Geographics, CNES/Airbus DS, USDA, USGS, AeroGRID, IGN, and the GIS User Community



GZA GeoEnvironmental, Inc.



# **Appendix D**

**CTDEEP Guidelines For Inspection And Maintenance Of Dams, 2001**



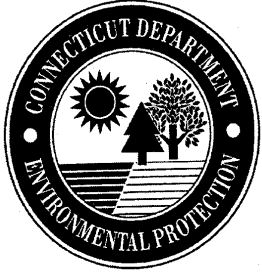

# Connecticut Department of Environmental Protection

Arthur J. Rocque, Jr.  
Commissioner



## **Guidelines for Inspection and Maintenance of Dams**

September 2001

**Department of Environmental Protection  
Bureau of Water Management  
Inland Water Resources Division  
(860) 424-3706**

Arthur J. Rocque, Jr.  
Commissioner

Jane K. Stahl  
Deputy Commissioner

Robert L. Smith  
Bureau Chief

Charles E. Berger, Jr.  
Director

Denise Ruzicka  
Assistant Director

Wesley D. Marsh  
Supervising, Environmental Analyst

**ACKNOWLEDGMENTS**

*From this project's inception through its publication, I had the opportunity to work with Phil Moreschi and Jim Otis of Fuss & O'Neill, Inc., who must be thanked for their patience, diligence and professionalism in preparing this manual. I also want to acknowledge the support of Charles Berger, Jr., Director and Denise Ruzicka, Assistant Director of the Inland Water Resources Division.*

*This manual would not have seen the light of day without the contribution of Wesley Marsh, Supervisor of the Dam Safety Section. His intelligence, honesty, practicality and comprehensive knowledge of Connecticut's dams have been invaluable.*

*Finally, I would like to acknowledge the contribution of David Majachier. Nearly a decade ago, while working for the Dam Safety Section, he envisioned what I hope we have accomplished with this manual. With great appreciation and respect, this manual is dedicated to David.*

*Ann Kuzyk  
Project Manager*

The Department of Environmental Protection is an affirmative action/equal opportunity employer, providing programs and services in a fair and impartial manner. In conformance with the Americans with Disabilities Act, DEP makes every effort to provide equally effective services for persons with disabilities. Individuals with disabilities needing auxiliary aids or services, accommodations to participate in a listed event or for more information by voice or TTY/TTD call (860) 424-3000.



# **Guidelines for Inspection and Maintenance of Dams**

Prepared for

Connecticut Department of Environmental Protection  
Bureau of Water Management  
Inland Water Resources Division

Prepared by

Fuss & O'Neill, Inc.  
146 Hartford Road  
Manchester, CT 06040  
(860) 646-2469

## TABLE OF CONTENTS

### SECTION

- A. INTRODUCTION
  - Purpose and Scope
  - Importance of Dam Maintenance and Inspection
- B. DAM SAFETY REGULATIONS, OWNER RESPONSIBILITY AND LIABILITY
  - DEP Dam Safety Program Overview
  - Pertinent Statutes and Regulations
  - How Dams are Classified
  - Operation and Maintenance Plan Requirements
  - Inspection Requirements
  - Responsibility and Liability
- C. TYPES OF DAMS AND COMPONENTS
- D. TYPES OF FAILURE
  - Seepage/Piping
  - Overtopping/Erosion
  - Structural
  - Problems, Consequences, Recommended Actions
- E. PREVENTIVE MAINTENANCE
  - Embankment
  - Spillways
  - Intake/Outlet Structures
  - Masonry and Rubble Walls
  - Miscellaneous Safety and Access Features
- F. MAINTENANCE SUMMARY AND SCHEDULE TABLE
- G. INSPECTION CHECKLIST
- H. REPAIR ASSISTANCE AND EMERGENCY INFORMATION
  - When a Permit May Be Required
  - When to Contact a Professional Engineer
  - Emergency Operation Plan
  - Local Emergency Management Role
  - Emergency Telephone Numbers

### GLOSSARY OF TERMS

### APPENDIX

- Inspection Checklist

## **APPENDIX**

Funding for the development and publication of this document was provided by a grant from the Federal Emergency Management Agency in cooperation with the Association of State Dam Safety Officials. In preparing this manual, similar publications from the States of Missouri and Colorado were valuable sources of ideas and information.

## A. INTRODUCTION

### Purpose and Scope

Dams are barriers typically constructed across a stream channel to impound water. Dams are man-made structures requiring routine inspection and maintenance. Several dams fail every year due to lack of maintenance, and in most cases failure could have been prevented.

This manual was developed to assist and encourage the many owners of small dams in Connecticut to inspect and maintain their dams on a regular basis. It is intended to be a useful guide for owners to refer to while performing these activities. By inspecting a dam on a regular basis, and becoming familiar with the structure, the owner can recognize important changes more readily over time.

A number of inspection and maintenance practices for various types of dams are covered, although an emphasis has been placed on earth and earth/masonry structures since they are the most common types of small dams in Connecticut.

### Importance of Dam Maintenance and Inspection

**Impact of Dam Failure:** Dam failure may result in the loss of life, property and income. The loss or significant lowering of a pond or lake impounded by a dam may cause hardship for those dependent on it for their livelihood or water supply. The loss of a dam may also alter existing wetlands and eliminate recreational opportunities for swimming, fishing and boating. The



*Dam Failure*

likelihood of future residential and commercial development occurring both downstream of dams and adjacent to impoundments means that the potential for such losses will continue to grow over time. Adhering to the maintenance and inspection guidelines of this manual is not only an important endeavor for dam owners but also a legal requirement.

**Regular Inspection:** Regular inspection is vital to the proper care and maintenance of dams. A regular inspection program is essential in preserving the integrity of a dam and avoiding costly repairs. Dams are subject to erosion, corrosion, and deterioration by wind, rain, ice and temperature. Water passing over, under and through dams can weaken these structures over time. A regular inspection program should start just after construction is completed and continue throughout the life of a dam.

## B. DAM SAFETY REGULATIONS, OWNER RESPONSIBILITY AND LIABILITY

### DEP Dam Safety Program Overview

The Dam Safety Section of the Inland Water Resources Division of the Connecticut Department of Environmental Protection (DEP) is responsible for administering and enforcing Connecticut's dam safety laws. The existing statutes require that permits be obtained to construct, repair or alter dams, dikes and similar structures and that existing dams, dikes and similar structures be registered and periodically inspected to assure that their continued operation and use does not constitute a hazard to life, health or property.

### Pertinent Statutes and Regulations

The dam safety statutes are codified in Sections 22a-401 through 22a-411 of the Connecticut General Statutes (CGS). Sections 22a-409-1 through 22a-409-2 of the Regulations of Connecticut State Agencies (RCSA) govern the registration and safety inspection of dams in Connecticut. A copy of these statutes and regulations are available from the Dam Safety Section of the Inland Water Resources Division of the DEP by calling (860) 424-3706.

### How Dams are Classified

DEP assigns dams to one of five classes according to their hazard potential:

- a. Class AA: negligible hazard potential dam which, if it were to fail, would result in no measurable damage to roadways, land and structures, and negligible economic loss.
- b. Class A: low hazard potential dam which, if it were to fail, would result in damage to agricultural land, damage to unimproved roadways, or minimal economic loss.
- c. Class BB: moderate hazard potential dam which, if it were to fail, would result in damage to normally unoccupied storage structures, damage to low volume roadways, or moderate economic loss.
- d. Class B: significant hazard potential dam which, if it were to fail, would result in possible loss of life;

minor damage to habitable structures, residences, hospitals, convalescent homes, schools, etc.; damage to or interruption of the use or service of utilities; damage to primary roadways and railroads; or significant economic loss.

- e. Class C: high hazard potential dam which, if it were to fail, would result in the probable loss of life; major damage to habitable structures, residences, hospitals, convalescent homes, schools, etc.; damage to main highways; or great economic loss.

The classification of a dam can change due to changes in downstream development. As shown in the chart below, 83% of dams in Connecticut fall within the negligible to moderate hazardous categories while only 17% fall within the significant and high hazard categories.

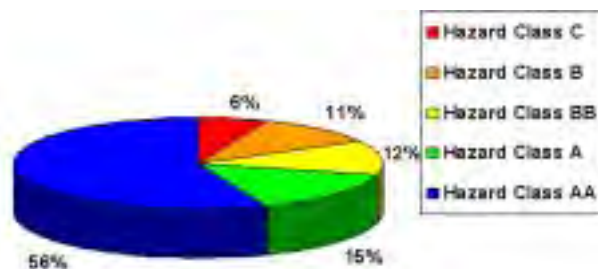

*Connecticut Dams by Hazard Class*

### Operation and Maintenance Plan Requirements

DEP typically requires owners of Class B and C hazard classification dams to prepare individual Operation & Maintenance Manuals for their dams, while owners of Class A and BB dams are not routinely required to do so. The DEP created this manual in order to help the owners of Class A and BB dams inspect and maintain these lower hazard structures. In addition, this manual may also serve as a starting point for the preparation of individual Operation & Maintenance Manuals for Class B and C dams.

## Inspection Requirements

DEP is charged with periodically inspecting all dams subject to the jurisdiction of the Commissioner. These are dams which by breaking away would cause property damage or loss of life. Information regarding the inspection process is contained in 22a-409-2 of the RCSA.

<b><u>Hazard Class</u></b>	<b><u>Inspection Frequency</u></b>
<b>AA</b>	<b>At least once</b>
<b>A</b>	<b>Every 10 years</b>
<b>BB</b>	<b>Every 7 years</b>
<b>B</b>	<b>Every 5 years</b>
<b>C</b>	<b>Every 2 Years</b>

*Periodic DEP Inspections*

Dam owners are encouraged to visit and inspect their dam frequently in order to become familiar with its features and current condition. This allows important changes to be detected quickly.

Dam owners may consider obtaining insurance to provide coverage in the event of damages and claims resulting from a dam failure. Contact your homeowners insurance agent for more information.

## Responsibility and Liability

Owners of dams are legally responsible for the operation and maintenance of their structures. Negligence by dam owners in fulfilling their responsibilities can negatively impact downstream and adjacent residents and properties.

Section 22a-409-2(j) of the RCSA outlines owner responsibilities including:

- a. Inspection of the dam to assure no unsafe conditions are developing, e.g., due to weather, animal activity, vandalism.
- b. Notification to DEP of any major damage such as overtopping by flood waters, erosion of the spillway discharge channel, new seepage, settling, cracking or movement of the embankment.
- c. Maintenance of structure and adjacent area to remain free of brush and tree growth.
- d. Written records of all inspections and maintenance activities undertaken.

### C. TYPES OF DAMS AND COMPONENTS

Various materials are used for dam construction including earth, timber, rock, concrete and steel. Most dams in Connecticut are constructed of earth or combinations of earth and other materials. Dams are provided with spillways to safely pass a broad range of flows over, around or through the dam. Dams often have a drain or similar mechanism to control water levels in the impoundment for maintenance or emergency purposes.

Some typical dam configurations are described below:

- a. Earthfill Dam: in which more than 50% of the volume consists of soil. This type of dam is often referred to as an Embankment Dam.
- b. Zone Embankment Dam: composed of zones of selected materials having different degrees of permeability.

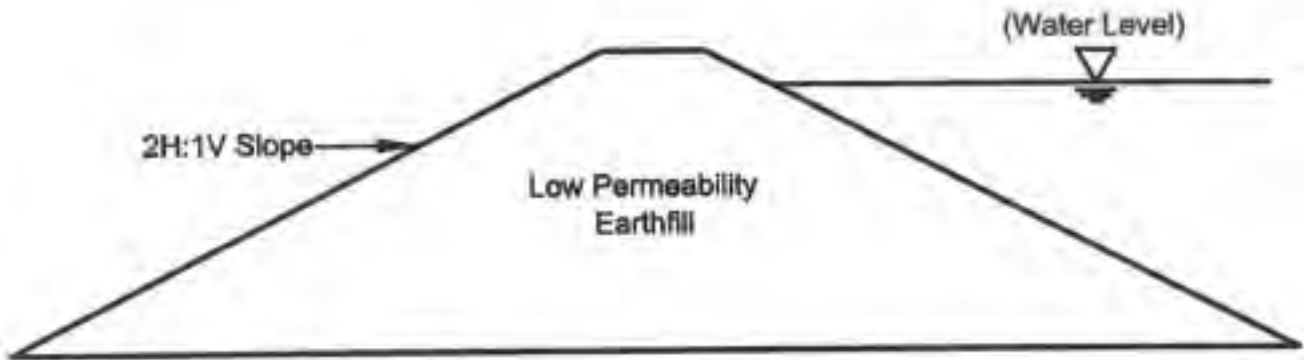

*Earthfill Dam*

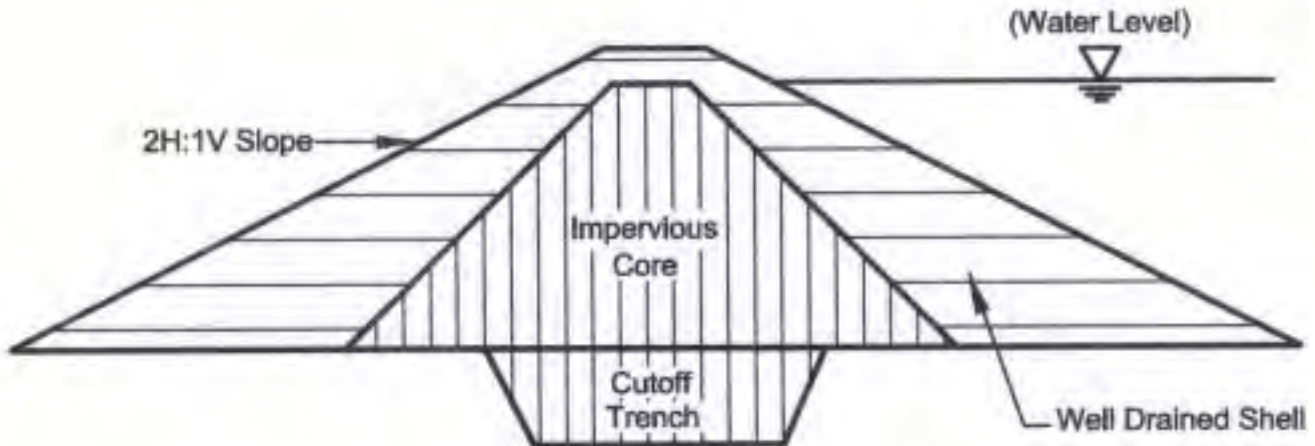

*Zone Embankment Dam with Cutoff Trench*



- c. Masonry Dam: constructed mostly of shaped stone, brick or concrete blocks that may or may not be joined by mortar.
- d. Rubble Dam: constructed of unshaped coarse stone or fragments of stones, not placed in courses, that may or may not be joined by mortar.
- e. Masonry Wall/Earthfill Dams: consisting of earth embankment with one or two masonry rubble rock faces; walls on downstream and/or upstream faces are generally vertical.
- f. Concrete Dam: constructed primarily of cast-in-place concrete.
- g. Concrete Wall/Earthfill Dam: consisting of earth embankment with one concrete wall, generally vertical and on the upstream face.

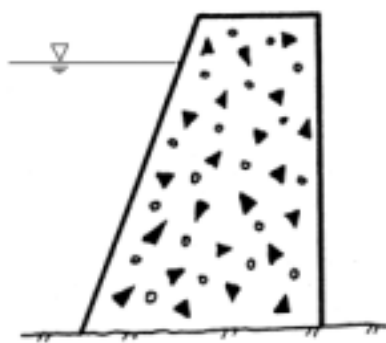

*Concrete Dam*

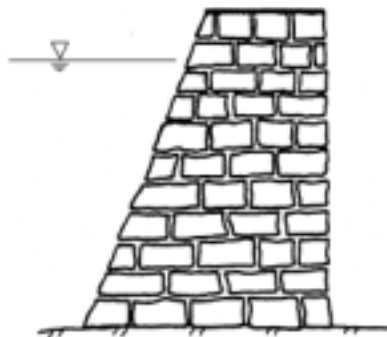

*Masonry Dam*

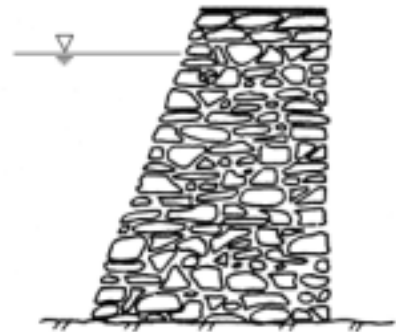

*Rubble Dam*

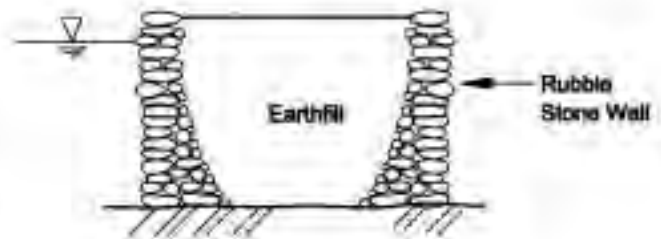
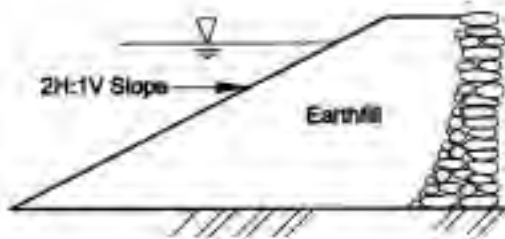

*Masonry Wall/Earthfill Dams*

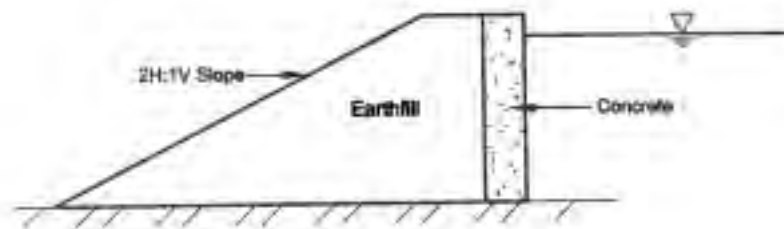

*Concrete Wall/Earthfill Dam*

The common components of a typical earthfill dam are illustrated below. Descriptions of some common dam components are also given below.

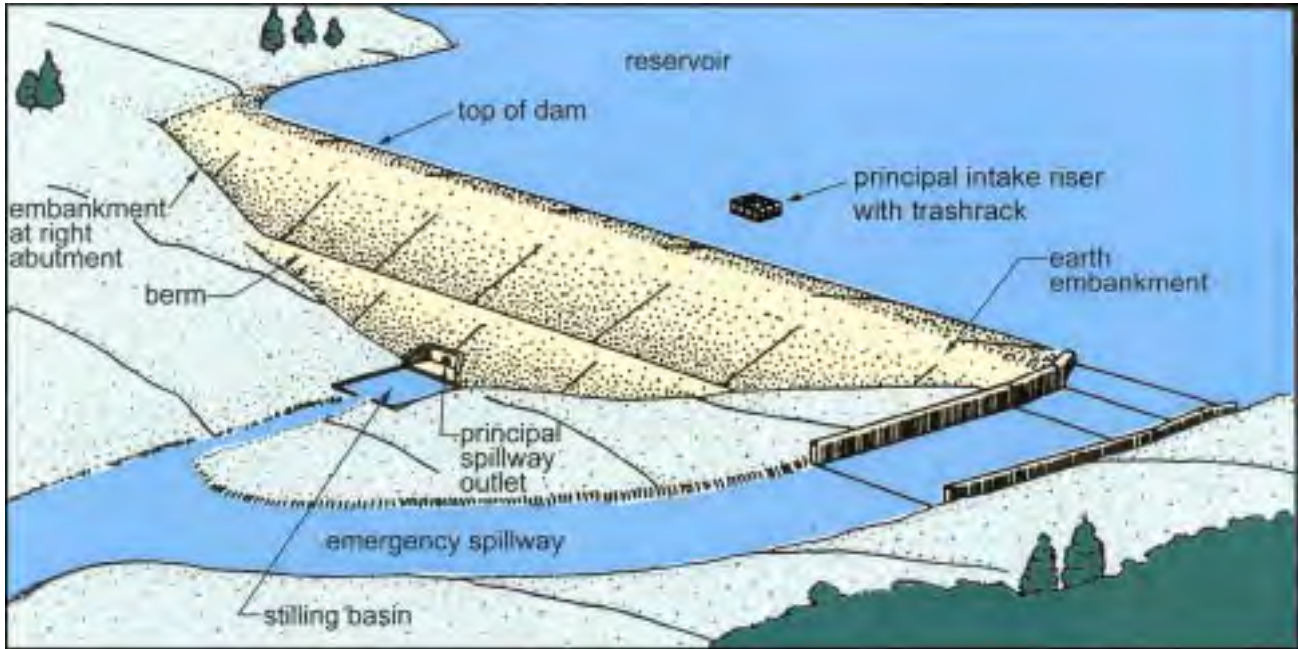

*Earthfill Dam*

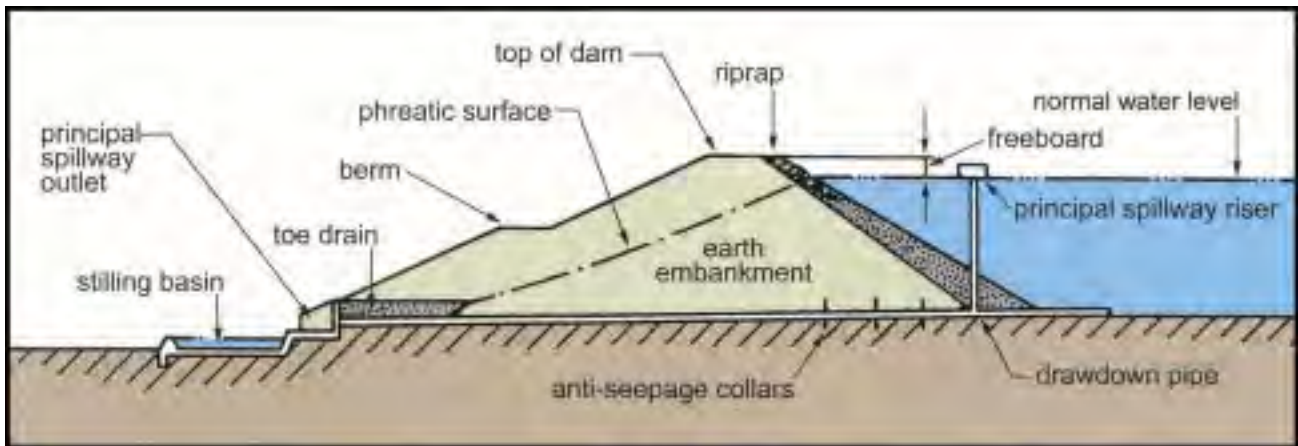

*Section Through Dam*

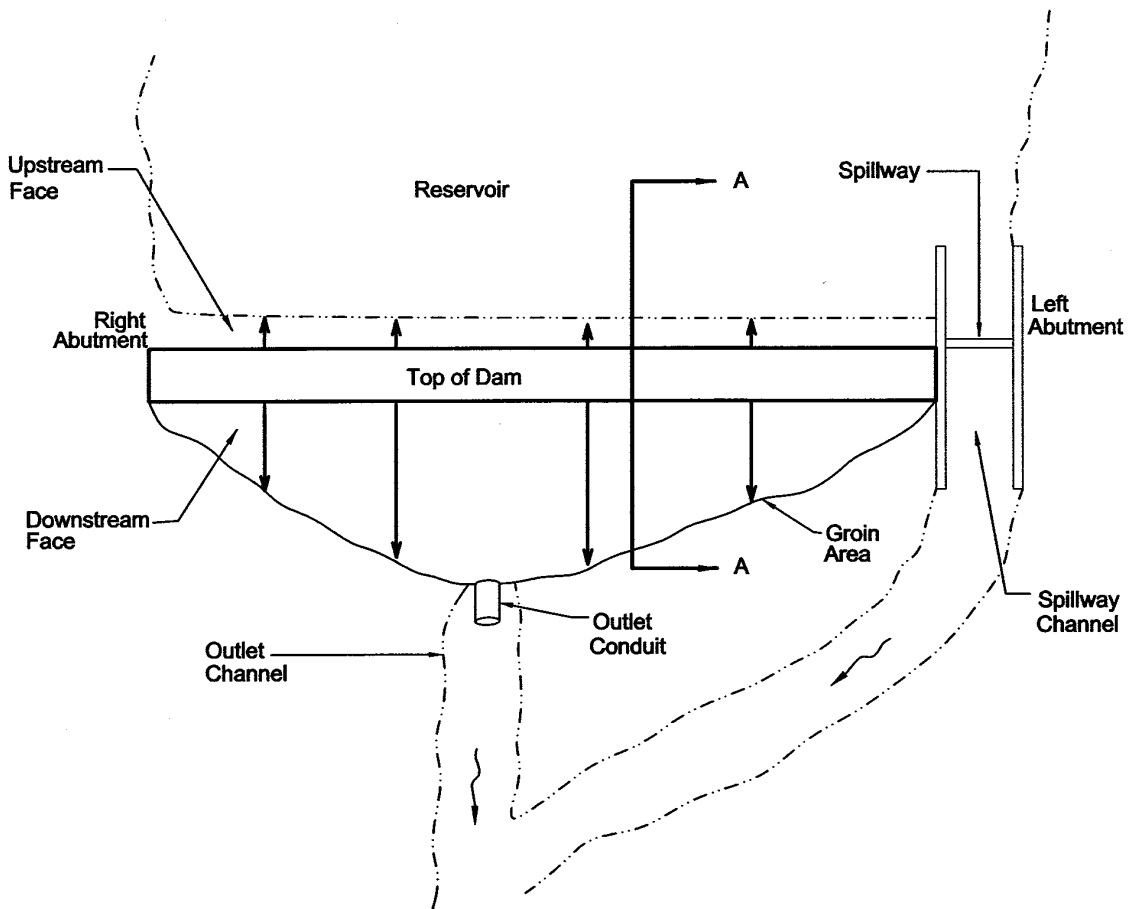

**Plan View**

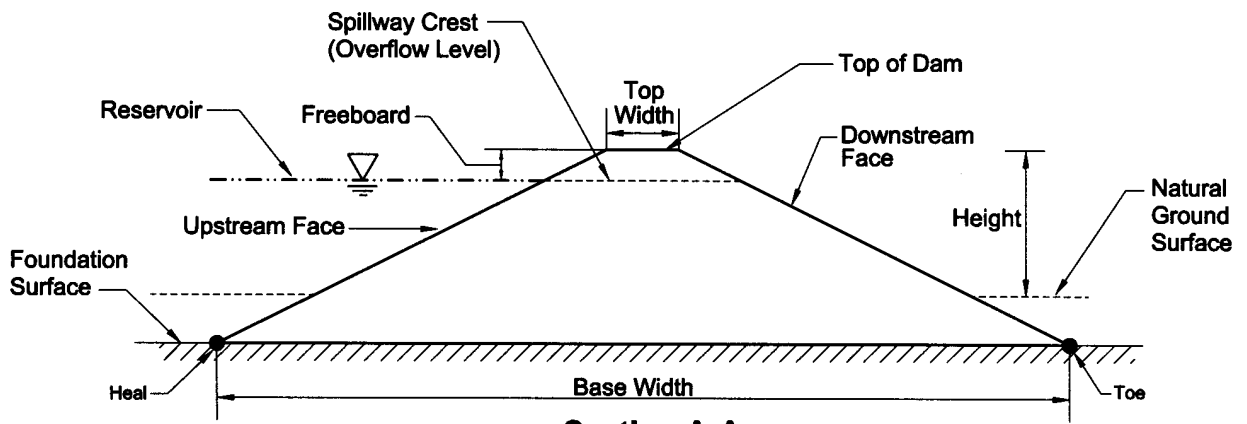

**Section A-A**

## Embankment

The embankment is the primary part of the dam. It is the section which impounds and resists the forces of the water. A homogeneous embankment is composed of essentially the same material throughout, while a zoned embankment has different materials, such as clay or rock, incorporated into some areas. Seepage through the dam embankment may be collected and controlled by an internal drainage system such as a toe drain or foundation drain.



*Well Maintained Embankment*

## Spillways

The principal spillway establishes the normal water level of the pond or lake. The function of the principal spillway is to allow normal flow to pass the dam in a safe and non-erosive manner. An emergency spillway is an auxiliary spillway designed to pass flood flows greater than the principal spillway's capacity in order to prevent the dam from overtopping during extreme storms. Spillways must be resistant to erosion because their failure may be as significant as an embankment failure and may well lead to dam failure. Because flows in spillways may reach high velocities, a stilling basin or plunge pool is often used to prevent erosion.



*Spillway*

## Intake/Outlet Structures

Also referred to as drawdown facilities, these structures help control impoundment levels and drain a reservoir for normal maintenance or emergency purposes. Most drawdown facilities consist of a pipe through the dam with a valve which may be operated as needed. The dam spillway and drawdown structures may be built in close proximity to one another, and an outlet structure may be incorporated into the principal spillway structure.



*Intake Structure*

## Masonry and Rubble Walls

Many masonry and rubble-wall-faced earth dams exist in Connecticut. In some instances properly graded gravel was placed immediately behind the wall to provide a drainage outlet for any seepage moving through the earthfill. Spillway and spillway training walls have also been constructed with masonry/rubble walls. Evidence of any seepage, subsidence or undercutting of these walls is best observed with the impoundment at spillway crest elevation to assess whether the crest is level. The structure should then be viewed with no flow over the spillway to assess the degree and location of seepage/leakage and the presence of scour or undercutting erosion at the toe.



*Rubble Wall*

## Miscellaneous Safety and Access Features

Fences, handrails, gates, access roads, bridges and warning signs serve to improve access and personal safety. Fences also discourage vandalism.

## Relative Numbers for Types of Dams

As shown in the chart below, 77 percent of Connecticut dams in the negligible to moderate hazard categories are constructed primarily of earth, masonry or a combination of these materials.

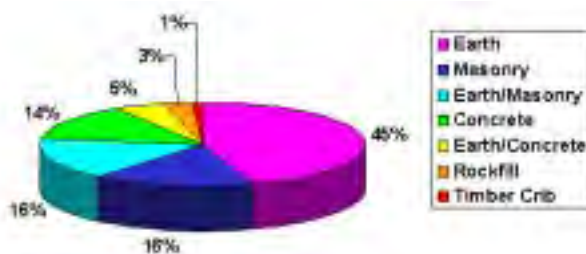

*Construction of Types AA, A and BB Dams  
in Connecticut*

## D. TYPES OF FAILURE

Dam failures usually result from poor design, improper construction, inadequate maintenance, or a combination of the above. Although the manner in which a dam fails and the particular causes of failure are often varied and complex, failures can generally be grouped into the following three types:

### Seepage/Piping

All earth dams have seepage due to water movement through the dam and its foundation, however, the rate of seepage must be controlled. Uncontrolled seepage can progressively erode soil from the embankment or its foundation in an upstream direction towards the reservoir and develop a flow conduit (pipe) to the reservoir. This phenomenon is known as “piping.” Uncontrolled seepage may also weaken the soil and lead to a structural failure. Common causes of seepage/piping include rodent activity, tree roots and poor construction.

### Overtopping/Erosion

Overtopping failures result from the erosive action of the uncontrolled flow of water over, around or adjacent to the dam. Earth embankments are not designed to be overtopped and therefore are particularly susceptible to erosion. Surface erosion may reduce the embankment cross-section, saturate an earth embankment and lead to a structural failure. General causes of overtopping include inadequate spillway size and/or spillway blockage by debris.



*Dam Failure*

### Structural

Structural failures can occur in the dam itself or its foundation. Structural failure of a spillway, draw-down facility, concrete wall or other appurtenance can lead to a total dam failure. Cracking, settlement and slides are common signs of structural failure which often result from uneven settlement of foundation materials and/or poor workmanship during construction.

### Problems, Consequences, Recommended Actions

Various observable problems, their possible consequences, and recommended actions are grouped below by failure type.

**SEEPAGE/PIPING  
PROBLEM**

**POSSIBLE  
CONSEQUENCES**

**RECOMMENDED  
ACTIONS**

**Seepage Water Exiting at  
Abutment Contact**



Can lead to erosion of embankment materials and failure of the dam.

Study leakage area to determine quantity of flow and extent of saturation. Stake out the saturated area and monitor for growth or shrinkage. Inspect frequently for slides. Water level in the impoundment may be lowered to increase embankment safety. A **QUALIFIED ENGINEER** should inspect the conditions and recommend further actions to be taken.

**Seepage Water Exiting as a  
Boil in the Foundation**

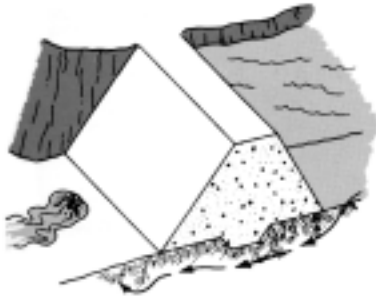

Continuous flows can lead to piping erosion of the foundation and failure of the dam.

Examine boil for transportation of foundation materials, evidenced by discoloration. If soil particles are moving downstream, create a sand bag or earth dike around the boil. This is a temporary control measure. The pressure created by the water level within the dike may control flow velocities and prevent further erosion. If erosion continues, lower the reservoir level. A **QUALIFIED ENGINEER** should inspect the condition and recommend further actions to be taken. **CONTACT DEP DAM SAFETY PERSONNEL.**

**Spongy Condition at Toe of  
Dam**

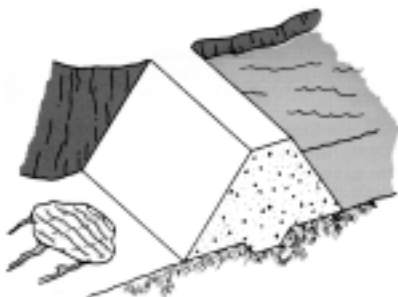

Condition shows excessive seepage in the area. If control layer of turf is destroyed, rapid piping erosion of foundation materials could result in failure of the dam. Marked change in vegetation may be present.

Carefully inspect the area for outflow quantity and any transported material. A **QUALIFIED ENGINEER** should inspect the condition and recommend further actions to be taken. **CONTACT DEP DAM SAFETY PERSONNEL.**

## SEEPAGE/PIPING PROBLEM

## POSSIBLE CONSEQUENCES

## RECOMMENDED ACTIONS

### Rodent Activity

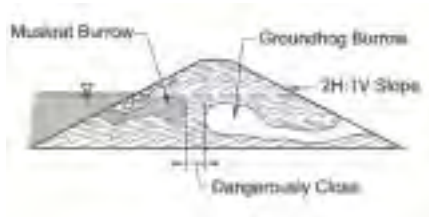

Can reduce length of seepage path and lead to piping erosion failure. If rodent tunnel exists through most of the dam, it can lead to failure of the dam.

Control rodents to prevent more damage. Determine exact location of digging and extent of tunneling. Remove rodents and backfill existing holes.

### Seepage Water Exiting From a Point Adjacent to the Outlet



Continued flows can lead to rapid erosion of embankment materials and failure of the dam.

Investigate the area by probing and/or carefully shoveling to see if the cause can be determined. Determine if leakage water is carrying soil particles evidenced by discoloration. Determine quantity of flow. If flow increases, or is carrying embankment materials, reservoir level should be lowered until leakage stops. A QUALIFIED ENGINEER should inspect the condition and recommend further actions to be taken. CONTACT DEP DAM SAFETY PERSONNEL.

### Sinkhole

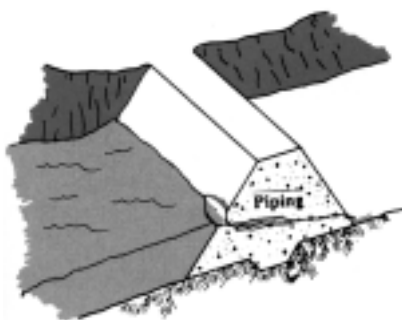

Piping erosion can empty a reservoir through a small hole or can lead to dam failure as soil pipes erode. Dirty water at the exit indicates erosion.

Inspect other parts of the dam for seepage or more sinkholes. Identify exact cause of sinkholes. Check seepage and leakage outflows for dirty water. A QUALIFIED ENGINEER should inspect the conditions and recommend further actions to be taken. CONTACT DEP DAM SAFETY PERSONNEL.



**SEEPAGE/PIPING  
PROBLEM**

**POSSIBLE  
CONSEQUENCES**

**RECOMMENDED  
ACTIONS**

**Trees /Brush**



Large tree roots can create seepage paths. Brush can obscure visual inspection and harbor rodents. Decaying root systems can provide seepage paths. Wind thrown tree can create void in dam.

Remove all trees and shrubs on and within 25 feet of the embankment. Properly backfill void with compacted material. A QUALIFIED ENGINEER may be required; CONTACT DEP DAM SAFETY PERSONNEL.

**OVERTOPPING/EROSION  
PROBLEM**

**POSSIBLE  
CONSEQUENCES**

**RECOMMENDED  
ACTIONS**

**Blocked/Inadequately Sized  
Spillway**

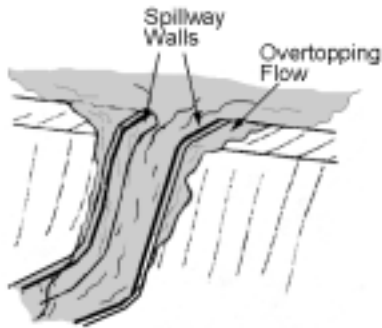

May reduce discharge capacity and cause overflow of spillway and/or dam overtopping. Dam, if overtopped frequently, can erode and/or fail.

Remove debris blockage (e.g. beaver dams) regularly. Measure quantity of flow depth in spillway for various rain events. Control vegetative growth in spillway channel. Install log boom or trash rack in front of spillway entrance to intercept floating debris. A **QUALIFIED ENGINEER** should inspect the conditions and recommend further actions to be taken.

**Broken Down or Missing  
Riprap**

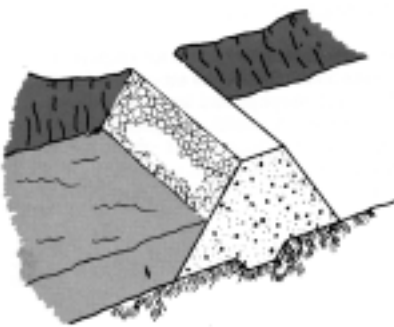

Wave action against unprotected areas decreases embankment width. Soil is eroded away which allows riprap to settle, providing less protection and decreased embankment width.

Re-establish normal slope. Place bedding and competent riprap. **ENGINEER REQUIRED** for design of bedding and riprap.

**Erosion**

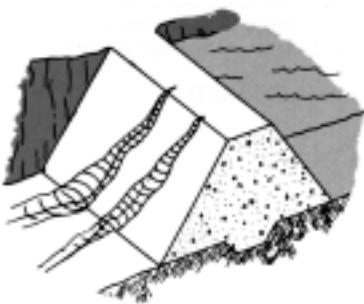

Erosion can lead to eventual deterioration of the downstream slope and failure of the structure. Can reduce available freeboard and/or cross-sectional area of dam. Can result in a hazardous condition if due to overtopping.

Protect eroded areas with riprap. Compacted soil and re-establishing turf may be adequate if the problem is detected early. If gully was caused by overtopping, provide adequate spillway designed by a **QUALIFIED ENGINEER**.

**OVERTOPPING/EROSION  
PROBLEM**

**POSSIBLE  
CONSEQUENCES**

**RECOMMENDED  
ACTIONS**

**Pedestrian/Vehicle Traffic**

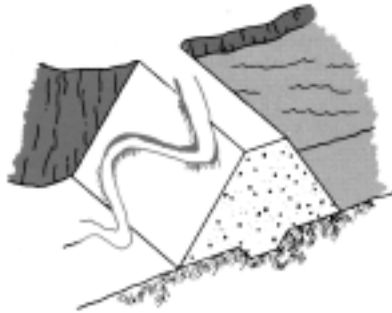

Creates areas bare of erosion protection and causes erosion channels. Allows water to stand and makes area susceptible to drying cracks.

Prohibit access using fence, signs. Repair erosion protection with riprap or grass. If access is needed or required, provide a formal access way designed to prevent erosion.

**Ruts/Puddling Along Crest**

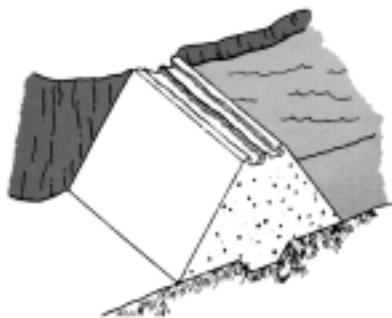

Allows standing water to collect and saturate crest of dam. Vehicles can get stuck.

Regrade and recompact crest to provide proper drainage to upstream slope. Install gravel or road base material to accommodate traffic.

**Missing/Deteriorated Riprap  
Channel Lining**

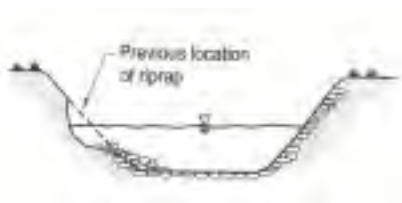

Erosive action displaces channel lining and washes sediment downstream.

Install properly graded riprap in channel lining with filter material to prevent soil from being washed out through spaces in the riprap.

**STRUCTURAL  
PROBLEM**

**POSSIBLE  
CONSEQUENCES**

**RECOMMENDED  
ACTIONS**

**Large Cracks, Slide, Slump or Slip**

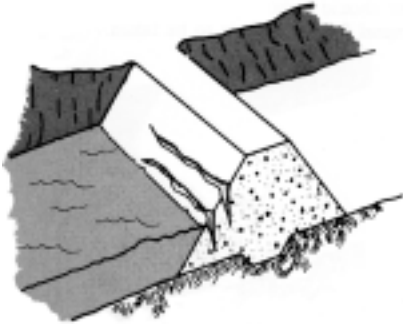

Large cracks indicate onset of massive slide or settlement caused by foundation failure. A series of slides can lead to obstruction of the outlet or failure of the dam. If massive slide cuts through crest or upstream slope, reducing free-board and cross section, structural collapse or overtopping can result.

Measure extent and displacement of slide. If continued movement is seen, begin lowering water level until movement stops. A QUALIFIED ENGINEER should inspect the condition and recommend further action. CONTACT DAM SAFETY PERSONNEL.

**Cracked or Deteriorated  
Concrete Face**

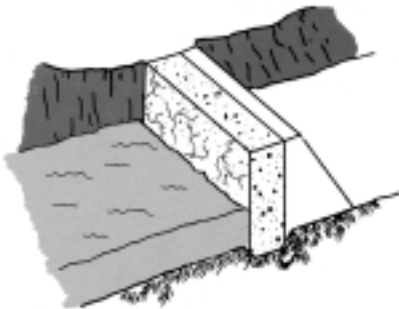

Ice action may further weaken or displace concrete by freezing and thawing.

Determine cause. Either patch with grout or contact engineer for permanent repair method. If damage is extensive, a QUALIFIED ENGINEER should inspect the conditions and recommend further actions to be taken.

**Wall Displacement/Open  
Joints**

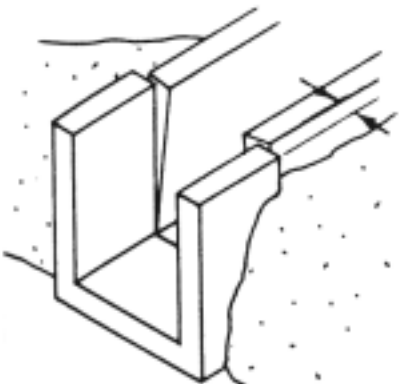

Minor displacement will create eddies and turbulence in the flow, causing erosion of the soil behind the wall. Erosion of foundation material may weaken support and cause further displacement. Major displacement will cause severe cracks and eventual failure of the structure.

Reconstruct displaced structure. Water-stops should be used at joints where feasible. Consult a QUALIFIED ENGINEER before actions are taken.

## STRUCTURAL PROBLEM

## POSSIBLE CONSEQUENCES

## RECOMMENDED ACTIONS

### Large Cracks

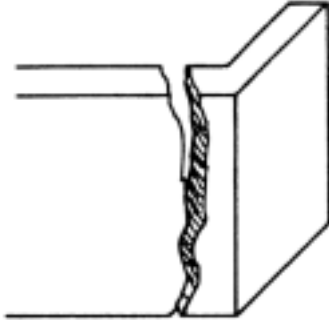

Disturbance in flow patterns; erosion of foundation and backfill; eventual collapse of structure. May allow entrance of water which could cause freeze and thaw damage and further weaken structure.

Cracks without large displacement may be repaired by patching, in which case surrounding areas should be cleaned or cut out before patching. Installation of weep holes or other actions may be needed. A QUALIFIED ENGINEER should inspect the condition and recommend such further actions.

### Leakage Through Joints or Cracks

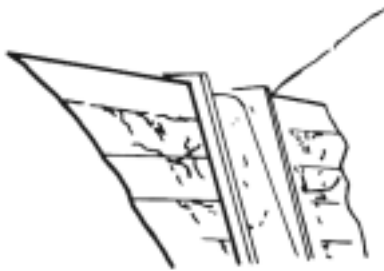

Can cause walls to tip over. Flows through concrete can lead to rapid deterioration from weathering. If the spillway is located within the embankment, rapid erosion can lead to failure of the dam.

Check area behind wall for puddling of surface water. Check and clean drain outfalls, flush lines, and weep holes. If condition persists a QUALIFIED ENGINEER should inspect the condition and recommend further actions to be taken.

### Tree Growth in Masonry Walls

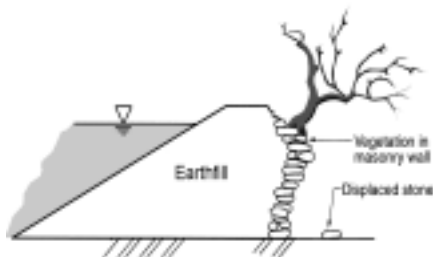

Can weaken or disintegrate wall by dislodging masonry or rubble stone.

Control excessive brush through regular routine maintenance (removal). Remove large trees, stumps and roots under the direction of a QUALIFIED ENGINEER.

**STRUCTURAL  
PROBLEM**

**POSSIBLE  
CONSEQUENCES**

**RECOMMENDED  
ACTIONS**

**Leaning/Bulging Masonry  
Walls**

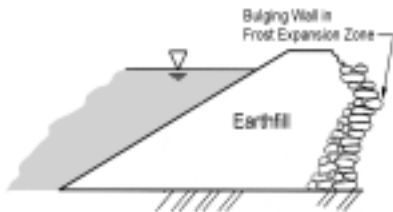

Freezing/thawing of silty/clayey soils push (lean) masonry walls out of vertical alignment. Missing stones can weaken wall and lead to wall failure.

Monitor movement over time. Replace lost or unsuitable soils behind wall or brace downstream face with riprap or washed stone. Replace missing stones, choke and/or chink gaps in wall. Depending upon extent of displacement/condition, a QUALIFIED ENGINEER may be required. CONTACT DEP DAM SAFETY PERSONNEL.

**Outlet Pipe Damage:**

**Hole, Crack**



**Joint Offset**

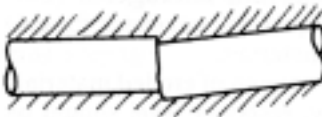

Provides passageway for water to exit or enter pipe, resulting in erosion of internal materials of the dam.

Check for evidence of water either entering or exiting pipe. Tap pipe in vicinity of damaged area, listening for hollow sound which indicates a void has formed along the outside of the conduit. If a progressive failure is suspected, request advice from a QUALIFIED ENGINEER. CONTACT DEP DAM SAFETY PERSONNEL.

**Control Works**

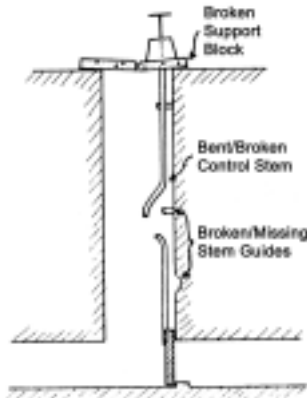

Loss of support for control stem. Stem may buckle and break under even normal use, resulting in loss of control.

Use of the system should be minimized or discontinued. If the outlet system has a second control valve, consider using it to regulate releases until repairs can be made.

**STRUCTURAL  
PROBLEM**

**POSSIBLE  
CONSEQUENCES**

**RECOMMENDED  
ACTIONS**

**Valve Leakage:**

**Debris Stuck Under Gate**

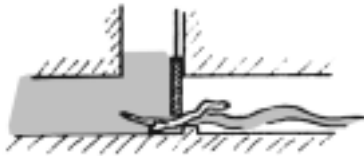

Gate will not close. Gate or stem may be damaged in effort to close gate.

Raise and lower gate slowly until debris is loosened and floats past valve. When reservoir is lowered, repair or replace trashrack.

**Cracked Gate Leaf**

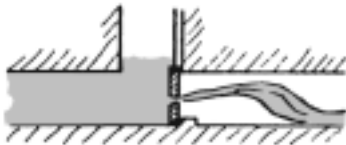

Gate leaf may fail completely, evacuating reservoir.

Use valve only in fully open or closed position. Minimize use of valve until leaf can be repaired or replaced.

**Damaged Gate Seat or Guides**

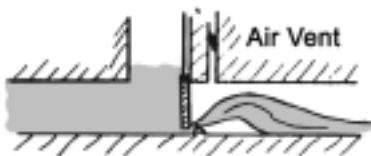

Leakage and loss of support for gate leaf. Gate may bind in guides and become inoperable.

Minimize use of valve until guides/seats can be repaired. Check to see if air vent pipe exists and is unobstructed.

## E. PREVENTIVE MAINTENANCE

Because dams are subject to deterioration over time, and seemingly minor deficiencies can quickly develop into major problems, all dam components and appurte-

nances should be inspected and maintained regularly. Routine maintenance recommendations are provided below by dam component.

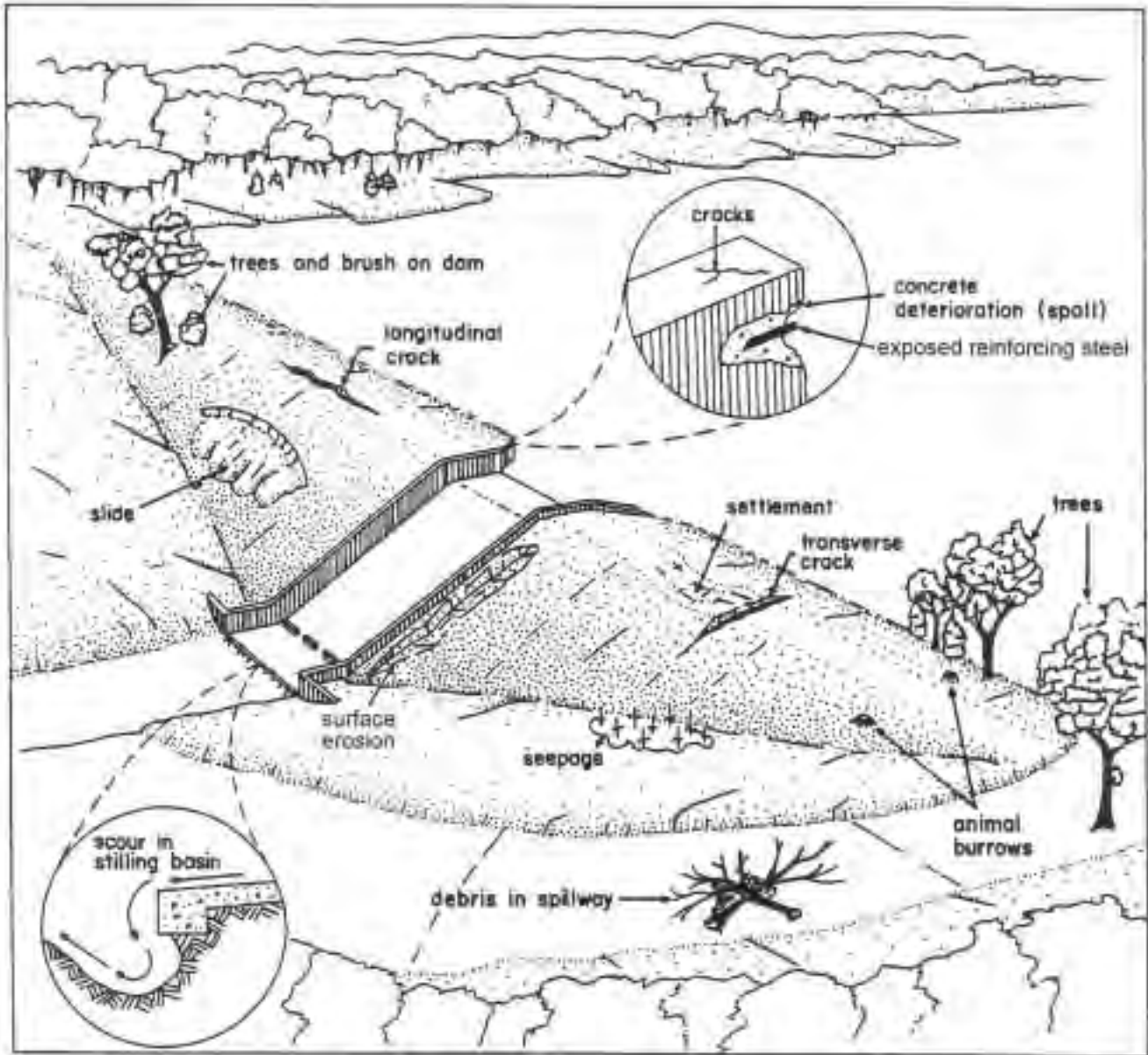

*Typical Deficiencies*



## Embankment

Recommended routine maintenance procedures and frequencies include:

- a. Vegetation Control - twice per year
  - Mow grass to maintain visibility of dam surfaces and remove woody vegetation from within 25 feet of all dam components
  - Maintain a healthy stand of grass to prevent erosion and growth of woody vegetation
- b. Rodent Control - as required
  - Fumigate burrow
  - Trap or eradicate rodent
  - Fill entire burrow with fill material



*Rodent Burrow*

- c. Minor Embankment and Erosion Repair - as required
  - Restore damaged/eroded areas with soil that is free from vegetation, organic matter, trash, large rock
  - Place and compact in thin (i.e., 6-inch) layers
  - Install topsoil and seed
- d. Erosion Protection - as required
  - Install rock, vegetation or other material (concrete or asphalt) where erosion protection is missing, damaged or otherwise required

## Spillways

Recommended routine maintenance procedures and frequencies include:

- a. Vegetation Control (for grass lined emergency spillways)
  - Mow grass twice per year
  - Maintain a healthy stand of grass to prevent erosion
  - Remove woody vegetation annually
- b. Minor Earthwork and Erosion Repair - as required
  - Replace missing soil with new soil that contains no vegetation, organic matter, trash or large rocks
  - Place and compact in thin (i.e., 6-inch) layers
  - Install topsoil and seed
- c. Erosion Protection - as required
  - Install rock, riprap, vegetation or other material (e.g., concrete or asphalt) where erosion protection is missing, damaged or otherwise required
  - Check downstream spillway channel for evidence of excessive siltation or erosion
- d. Concrete/Stone/Masonry Repair - as required
  - Consult DEP Dam Safety personnel and/or a professional engineer to determine appropriate repair
- e. Beaver Dam Removal - as required
  - Remove beaver flowage debris from spillway



*Beaver Dam in Spillway*

## Intake/Outlet Structures

Recommended routine maintenance procedures and frequencies include:

- a. Trashrack - after every major storm
  - Remove accumulated debris
  - Repair rusted or broken sections as needed
- b. Mechanical - once per year
  - Cycle (open and close) outlet gate valves through full operating range
  - Lubricate mechanisms per manufacturer's recommendation
  - Paint or grease ferrous metal surfaces as needed
  - Align stem guides or brackets
- c. Internal Conduit - once per year
  - Check for undermining or seepage around the outlet end
  - Check for corrosion or other deterioration of conduit material
  - Should deficiencies be detected, obtain immediate professional guidance before attempting repairs
- d. Concrete Features - once per year
  - Check for misalignment, cracks, spalls, scaling, exposed steel rebar, rust stains
  - Consult with DEP Dam Safety Personnel or a consultant engineer before attempting repairs



*Concrete Intake Structure*

## Masonry and Rubble Walls

Recommended routine maintenance procedures and frequencies include:

- a. Vegetation Control - twice per year
  - Remove woody vegetation within 25 feet of masonry dam structures
  - Cut trees growing in masonry walls flush with face of masonry
- b. Missing Stones - as required
  - Replace missing or misaligned capstones in spillway
  - Replace missing stone masonry in downstream and upstream walls
  - Do not mortar up or seal off the spaces or openings between the stones on the downstream face of masonry or rubble walls without first consulting a qualified engineer



*Leak in Masonry Wall*

## Miscellaneous Safety and Access Features

Recommended routine maintenance procedures and frequencies include:

- a. Maintain vehicular and pedestrian access features to allow future inspection and maintenance - once per year.
- b. Check fences, locks and signs for damage - once per year.



*Walkway, Hand Railing*



*Fence and Signage*

## F. MAINTENANCE SUMMARY AND SCHEDULE TABLE

This maintenance summary and schedule is intended to provide the owner with a quick reference of the recommended frequency intervals for inspecting and

performing routine maintenance on the components of a dam.

<b>Component</b>	<b>Maintenance Activity</b>	<b>Frequency</b>
Embankment	Vegetation control Rodent control Minor earthwork, erosion repair Erosion protection	Twice per year, minimum Check once per year, perform as required Check once per year, perform as required As required
Principal Spillway	Vegetation control Minor earthwork, erosion repair Erosion protection Concrete repair	Twice per year Check twice per year, perform as required Check twice per year, perform as required As required
Emergency Spillway	Vegetation control Minor earthwork, erosion repair Erosion protection Concrete repair	Twice per year Check twice per year Check twice per year As required
Intake/Outlet Structures	Trashrack cleaning Mechanical operation Internal conduit inspection Concrete features inspection	After every major storm Once per year Once per year Once per year
Masonry Walls	Vegetation control Missing stones	Twice per year As required
Miscellaneous Safety and Access Features	Vehicle/pedestrian access route(s) maintenance Fences, locks, signs inspection	Once per year Once per year

## **G. INSPECTION CHECKLIST**

Regular dam inspection and the review of inspection records are essential in assessing the need for carrying out dam repairs. By inspecting a dam on a regular basis, the owner can recognize changes in the structure over time. Very often the existence of a problem is not as important as its rate of development or a sudden change in its condition or extent.

The dam owner should keep records of all (routine and special) inspections in the form of notes, photo-

graphs and/or sketches. The inspection checklist found in the Appendix of this manual is intended to help the owner perform routine inspections in a consistent, efficient manner.

Each dam registered in the State of Connecticut has an assigned identification number unique to that dam. Contact the DEP Dam Safety Section to obtain the appropriate identification number for your dam.

## H. REPAIR ASSISTANCE AND EMERGENCY INFORMATION

### When a Permit May Be Required

The DEP Bureau of Water Management, Inland Water Resources Division, regulates the construction, alteration, repair or removal of dams, dikes, reservoirs and similar structures. This authority is derived from Sections 22a-401 through 22a-411 of the CGS. Consequently, any person or agency proposing to construct a dam, dike, reservoir or similar structure, or proposing to repair, alter or remove such a structure, must first obtain either a permit under CGS Section 22a-403 or 22a-411 from the DEP, or obtain a determination from DEP that such a permit is not required for the proposed activity. Pursuant to CGS Section 22a-401, DEP regulates dams “which, by breaking away or otherwise, may endanger life or property.” Dams whose failure does not endanger downstream life or property may not be regulated by DEP, but by the local inland wetlands or conservation commission where such dam is located.

Routine maintenance activities that do **not** require a construction permit from the DEP Dam Safety Section typically include the following:

- Grass mowing
- Cutting of brush or trees from the dam or adjacent areas
- Removal of debris and sediment from spillway intake areas and channels
- Restoration of minor eroded areas by placing topsoil, seed and mulch
- Minor patching of concrete structures
- Eradication of rodents and filling rodent holes
- Maintenance of drain valves (exercise, grease, adjust, repair valve stem and operators)

The local inland wetlands or conservation commission should be contacted prior to undertaking these types of activities to determine what, if any, local agency permits may be required.

Repair activities that **do** require a construction permit from the DEP Dam Safety Section typically include work of a more intrusive nature such as:

- Removal of tree roots and stumps and repair to earth embankments
- Reconstruction of severely deteriorated concrete

- structures or stone masonry walls
- Repair or replacement of damaged/deteriorated low level outlet pipes, conduits, valves
- Installation of drainage systems to control embankment or foundation seepage/leakage
- Flattening of embankment slopes
- Reconstruction of spillway, outlet control structure, walls

The DEP normally requires a dam construction permit for those repairs, alterations, or modifications to existing dams which, if improperly constructed, would adversely impact the structural integrity of the dam. Similarly, other proposed work which may affect the integrity of a dam, such as excavation adjacent to the dam, may require a DEP dam construction permit. DEP’s review of permit applications under CGS Section 22a-403 evaluates the structural and engineering aspects of the proposed dam repair, modification or alternation. In addition, the potential impact of the proposed construction on the environment, the safety of persons and property, and inland wetlands and watercourses are considered. The DEP must also determine the need for providing fish passage at the site in accordance with CGS Section 26-136.

Before obtaining a permit, plans and specifications by a licensed professional engineer must be submitted to the DEP Dam Safety Section of the Inland Water Resources Division for approval. After a permit is issued, a professional engineer familiar with dam construction (ideally the design engineer) must inspect the construction, certify completion of the work and prepare “as-built” plans of the structure. Following DEP approval of the permitted construction, a “Certificate of Approval” is issued to the owner of the dam in accordance with CGS Section 22a-405. The Owner must file the certificate on the land records of the town or towns in which the dam is located. The Certificate of Approval may contain specific terms and conditions regarding the dam’s inspection and operation which are intended to protect life and property.

### When to Contact a Professional Engineer

Regular dam inspection and prudent operation and maintenance by the owner will help identify and solve minor problems early and reduce the potential for

dam failure. However, since each dam is unique, this manual cannot begin to cover every possible condition/deficiency which may develop. The importance of contacting a qualified engineer when significant deficiencies are detected cannot be overemphasized.

A dam inspection by a qualified engineer provides a thorough, systematic evaluation of the condition of the dam. Such inspections should, at a minimum, be performed during construction of a new dam, modifications to an existing dam, and whenever potentially significant defects are first observed including:

- Earth slides in the embankment
- Uncontrolled seepage from dam, foundation boil
- Severe erosion of spillways or discharge channels
- Seepage around pipes
- Concrete deterioration (cracks, joint displacement)
- Pipe joint separation or damage
- Surface cracking
- Irregular settlement
- Sinkholes

A professional engineer may be located by checking the yellow pages section of the local telephone directory under the headings “professional engineers,” “consulting engineers” or “civil engineers.” Confirm that the engineer has experience with, and is qualified to inspect, dams.

### **Emergency Operation Plan**

Dam owners have historically been held liable for damages which occur as a result of dam failure. Owners therefore bear responsibility for reducing the potential hazard posed by their dams to downstream residents and property. Accordingly, the DEP requires that owners of Class B and C potential hazard dams prepare and implement an Emergency Operation Plan (EOP).

Guidelines for EOP preparation include three essential components:

- 1) An identification of the area inundated by a dam failure;

- 2) An established procedure for monitoring the dam during periods of heavy rainfall and runoff; and
- 3) A formalized warning system to alert the appropriate local emergency management officials charged with warning or evacuation responsibilities.

Usually, the owners of Class BB and A hazard potential dams are not required to prepare an EOP for their dams. However, the DEP encourages dam owners who wish to prepare an EOP to do so in accordance with the aforementioned guidelines. The guidelines are available from the DEP Inland Water Resources Division’s Dam Safety Section.

Even if an EOP has not been prepared for a dam, it is still prudent for the owner to inspect the dam whenever a “flood watch” or “flood warning” alert is issued by the National Weather Service for the county where the dam is located. It is also a good idea to inspect the dam immediately following a very heavy rainfall. A written record of these special dam inspections should be maintained.

### **Local Emergency Management Role**

If any of the following four conditions are observed during a flood watch or warning, the dam owner should notify the appropriate local emergency management agency that conditions at the dam may justify the evacuation of specific areas or closing certain roads due to the potential for flooding. Only local emergency management agencies have the authority to order the evacuation of residences or close roads.

- a. Dam is overtopping or nearly overtopping.
- b. Internal piping erosion of soil from the embankment or foundation has developed and caused a rapid increase in seepage, a muddy discharge near the downstream embankment toe, sinkholes appearing on or near the embankment, or a significant whirlpool (eddy) in the reservoir.
- c. A large slide or slough develops in the upstream or downstream embankment slope which threatens to

breach the embankment and release the impounded water.

- d. The sudden movement or failure of an appurtenant structure threatens the complete failure of the dam and release of its impoundment.

The dam owner is responsible for notifying, at a minimum, one local emergency management office or department. The local agency contacted should then notify other appropriate local agencies. The owner must contact the local government ahead of time to find out which telephone number(s) to call during or after normal business hours in the event of an emergency at the dam.

### **Emergency Telephone Numbers**

The following agencies typically have responsibility to act in response to an impending dam failure. A space is provided next to these agencies for the dam owner to fill in the appropriate contact information:

- a. Town/City Chief Executive:

---

---

---

- b. Local Police Department:

---

---

---

- c. Local Emergency Management Director:

---

---

---

- d. State Office of Emergency Management:

(860) 566-3180

---

---

- e. DEP Flood Emergency Operations Center:

(860) 424-3706 or (860) 424-3019

---

---

- f. DEP Communications Center:

(860) 424-3333 - after normal business hours

---

---

- g. State Police (Nearest Barracks):

---

---

---



## GLOSSARY OF TERMS

**ABUTMENT** - The natural ground that borders on either end of the dam structure. Right and left abutments are those on respective sides of the dam when an observer looks downstream.

**ANTI-SEEPAGE COLLAR** - A projecting collar of concrete or other material built around the outside of a tunnel or conduit within an embankment dam, to reduce the seepage potential along the outer surface of the conduit.

**APPURTENANCE** - Any structure or mechanism other than the dam itself which is associated with the dam's operation.

**AS-BUILT DRAWINGS** - Plans or drawings portraying the actual dimensions and conditions of a dam, dike, or levee as it was built. Field conditions and material availability during construction often require changes from the original design drawings.

**BLANKET DRAIN** - A drainage layer of sand or gravel placed directly over the foundation material to allow for the safe release of seepage flow.

**BOIL** - A disturbance in the surface layer of soil caused by water escaping under pressure from behind a water retaining structure such as a dam or levee. The boil may be accompanied by deposition of soil particles (usually sand) in the form of a conical-shaped mound (miniature "volcano") around the area where the water escapes.

**BREACH** - A break or opening in a dam which releases impoundment water either deliberately or accidentally.

**CHOKER OR CHINK** - Placement of stones on the upstream or downstream face (respectively) of a stone masonry or rubble wall.

**CONDUIT** - A closed channel to convey the discharge through or under a dam, typically a pipe.

**CONSTRUCTION JOINT** - The interface between two successive placements of concrete where bonding, not permanent separation, is intended.

**CONTRACTION JOINT** - A joint constructed such that shrinkage of the concrete would cause a crack.

**CORE** - A zone of material of low permeability, within an embankment, the purpose of which is to reduce the quantity of seepage through the dam.

**CORE WALL** - A wall of substantial thickness built of impervious materials, usually of concrete or asphaltic concrete, within an embankment to prevent leakage.

**CORROSION** - The chemical attack on a metal by its environment. Corrosion is a reaction in which metal is oxidized.

**CREST** - The crown of an overflow section of the dam. In the United States, the term "crest of dam" is often used when "top of dam" is intended. To avoid confusion, the terms crest of spillway and top of dam should be used for referring to the overflow section and dam proper, respectively.

**CUTOFF** - A relatively impervious barrier of soil, concrete, or steel constructed either to minimize the flow of water through pervious or weathered zones of a dam's foundation or to direct flow around such zones. May be a trench filled with impervious material or a wall of impervious material built into the foundation.

**DAM** - Any barrier which is capable of impounding or controlling the flow of water, including but not limited to stormwater retention or detention dams, flood control structures, dikes and incompletely breached dams.

**DRAINAGE LAYER OR BLANKET** - A layer of pervious material in a dam to relieve pore pressures or to facilitate drainage of the fill.

**DRAINAGE WELL** - Vertical wells or boreholes downstream of, or in the downstream berm of, an embankment to collect and control seepage through or under the dam and so reduce water pressure. A line of such wells forms a drainage curtain.

**DRAWDOWN** - The resultant lowering of water-surface level due to release of water from the reservoir.

**DROP INLET SPILLWAY** - A spillway consisting of a vertical pipe or conduit in the impoundment connected to a near horizontal pipe which passes through the dam and discharges downstream of the dam.

**EMBANKMENT** - Fill material, usually earth or rock, placed with sloping sides and usually longer than high.

**EMERGENCY SPILLWAY** - See Spillway.

**ENERGY DISSIPATER** - Any device constructed in a waterway to reduce the energy of fast-flowing water.

**EROSION** - Wear or scouring caused by the abrasive action of moving water.

**FACE** - The external surface limits of a structure, e.g., the face of a wall or dam.

**FAILURE** - An incident resulting in the uncontrolled release of water from an operating dam.

**FILTER** - A bank or zone of granular material that is incorporated in a dam and is graded (either naturally or by selection) to allow seepage to enter the filter without causing the migration of fill material from zones adjacent to the filter.

**FLOOD** - A general and temporary condition of partial or complete inundation of normally dry land areas.

**FLOOD PLAIN** - An area adjoining a body of water or natural stream that has been or may be covered by flood water.

**FOUNDATION OF DAM** - The natural material on which the dam structure is placed.

**FREEBOARD** - The vertical dimension between the top of the dam at its lowest point and the reservoir water surface elevation.

**GRAVITY DAM** - A dam constructed of concrete or masonry, which relies on its own weight for stability.

**GROIN AREA** - The area at the intersection of either the upstream or downstream slope of an embankment and the valley wall or abutment.

**GROUT** - A thin cement or chemical mortar used to fill voids, fractures, or joints in masonry, rock, sand and gravel, and other materials. As a verb, it refers to filling voids with grout.

**GULLY** - Rainfall erosion of earthen embankment slopes. Also may be caused in part by vehicular traffic or foot traffic.

**HEEL OF DAM** - The junction of the upstream face of a gravity dam with the foundation surface. In the case of an embankment dam the junction is referred to as the upstream toe of the dam.

**HEIGHT OF DAM** - The vertical distance measured from the downstream toe of the dam at its lowest point to the elevation of the top of the dam.

**HOMOGENEOUS EARTHFILL** - An embankment type construction of more or less uniform earth materials throughout, except for possible inclusion of internal drains or blanket drains. The term is used to differentiate from a zoned earthfill embankment.

**INTAKE** - Any structure in a reservoir, dam, or river through which water can be drawn from the impoundment or river to a discharge point.

**INTERNAL EROSION** - See Piping.

**INUNDATION MAP** - A map delineating the area that would be inundated in the event of a dam failure.

**LEAKAGE** - Uncontrolled loss of water by flow through a hole or crack.

**LOW-LEVEL OUTLET** - A low-level reservoir outlet, valve and pipe system through the dam generally used for lowering reservoir water level.

**MAXIMUM WATER LEVEL** - The maximum water level, including the flood surcharge, the dam is designed to withstand.

**NORMAL WATER LEVEL (NORMAL POOL)**- For a reservoir with a fixed overflow spillway crest, it is the lowest level of that crest.

**OBSERVATION WELL** - Small-diameter perforated vertical tube installed within an embankment. Used to measure the height of the internal water surface in the embankment at the location of the well.

**ONE-HUNDRED YEAR (100-YEAR) RETURN FREQUENCY FLOOD** - The flood magnitude with one percent chance of being exceeded in any given year. A 100-year rainfall event is currently said to occur when seven inches of precipitation falls in a 24-hour period.

**OUTLET** - An opening through which water can be freely discharged from a reservoir to a downstream channel.

**OWNER** - Any person or entity holding legal title to a dam or water obstruction.

**PERMEABILITY** - A material property which defines the material's capacity to transmit water.

**PERVIOUS ZONE** - A part of the cross section of an embankment dam comprising material of high permeability.

**PHREATIC SURFACE** - The upper surface of seepage in an embankment. All the soil below this surface will be saturated when the steady-state seepage condition has been reached.

**PIPING** - Progressive erosion and removal of soil by concentrated seepage flows through a dam, dike, or levee, its foundation, or its abutments. As material is eroded, the area of the "pipe" increases and the quantity and velocity of flow increase; these changes in turn result in the erosion of more material. The process continues at a progressively faster rate. Dam failure can result if the piping cannot be brought under control.

**RELIEF WELL** - See Drainage Well.

**RESERVOIR** - An impoundment of water created by a dam.

**RILL** - See Gully.

**RIPRAP** - A layer of large stone, broken rock, or precast blocks placed in random fashion on the slope of an embankment dam, on a reservoir shore or in a channel as a protection against erosive flows, waves and ice.

**SCALING** - The peeling away of a concrete surface.

**SEEPAGE** - The slow percolation of water through a dam, its foundation, or abutment. A small amount of seepage will normally occur in any dam or embankment that retains water.

**SEEPAGE COLLAR** - A projecting collar, usually of concrete, built around the outside of a pipe, tunnel, or conduit, under an embankment dam, to lengthen the seepage path along the outer surface of the conduit. Sometimes referred to as "anti-seepage collar."

**SLIDE** - The movement of a mass of earth or tailings down a slope. In embankments and abutments, this involves the separation of a portion of the slope from the surrounding material.

**SLOPE PROTECTION** - The armoring of the embankment slope against wave action and erosion, usually done by the installation of riprap.

**SLOUGH** - The separation from the surrounding material and downhill movement of a small portion of an earth slope. Usually this refers to a shallow earth slide.

**SPALLING** - Breaking (or erosion) of small fragments from the surface of concrete, masonry or stone under the action of weather or erosive forces.

**SPILLWAY** - A structure over or through a dam by which normal or flood flows are discharged. If the flow is controlled by gates, it is considered a controlled spillway; if the elevation of the spillway crest is the only control, it is considered an uncontrolled spillway. A principal spillway conveys normal flows; an emergency spillway is used to convey more infrequent flood flow.

**SPILLWAY CHANNEL** - A channel conveying water from the spillway crest to the water course.

**SPILLWAY DESIGN FLOOD** - The rainfall and run-off event used to design a dam's spillway capacity. The current DEP recommended minimum spillway design is the run off associated with the 100-year return frequency flood with an additional foot of freeboard.

**STILLING BASIN** - An energy-dissipating device at the outlet of a spillway to dissipate the high velocity (energy) of the flowing water, in order to protect the spillway structure and avoid serious erosion of the outlet channel and subsequent undermining.

**STOP LOGS** - Large logs, timbers, metal panels or steel beams, placed on top of each other with their ends held in guides on each side of a channel or conduit, to provide means of controlling or stopping the flow of water. Sometimes referred to as weir boards.

**STORAGE** - The retention of water or delay of runoff either by planned operation, as in a reservoir, or by temporary filling of overflow areas, as in the progression of a flood through a natural stream channel.

**TAILWATER LEVEL** - The level of water in the discharge channel immediately downstream of the dam.

**TOE OF DAM** - The base portion of a dam which intersects with natural ground at the downstream side.

**TOP OF DAM** - The elevation of the uppermost surface of a dam.

**TRASHRACK** - A device located at the intake of a conduit inlet or waterway to prevent entrance of some floating or submerged debris.

**UPLIFT** - The upward pressure in the pores of a material or on the base of a structure.

**UPSTREAM BLANKET** - An impervious layer placed on the reservoir floor upstream of a dam. In the case of an embankment, this blanket may be connected to the impermeable zone of the embankment.

**VALVE** - A device fitted to a pipeline or orifice to control or stop flow.

**WEEP HOLE** - A small pipe opening into structures such as concrete abutments, downstream mortared stone wall or concrete aprons to relieve any buildup of water pressure from seepage or groundwater.

**WEIR** - A type of spillway in which flow is constricted and caused to fall over a crest. Sometimes specially designed weirs are used to measure flow amounts.

**ZONED EARTHFILL** - An earthfill-type embankment, the cross section of which is composed of zones of selected materials having different degrees of porosity, permeability and density.













**DAM INSPECTION CHECKLIST (Cont.)**

**11. OTHER COMMENTS/OBSERVATIONS (Include Date):**

Empty rectangular area for recording other comments or observations.

**DAM INSPECTION CHECKLIST (Cont.)**

**12. SKETCHES:**

A large grid area for sketches, consisting of a 20x20 grid of squares. The grid is formed by dashed lines and is intended for drawing or sketching details related to dam inspection.

**DAM INSPECTION CHECKLIST (Cont.)**

**12. SKETCHES:**

A large grid area for sketches, consisting of a 20x20 grid of squares. The grid is formed by dashed lines and is intended for drawing or sketching. The grid covers the majority of the page below the '12. SKETCHES:' header.

## **Appendix F**

**International WaterPower and Dam Construction periodical article  
“Life-span of Storage Dams” by Martin Wieland, dated March 3, 2010**



---

# Life-span of storage dams

---

3 March 2010

38Share

---

*Dam engineers and dam owners may not always have a clear idea about the life-span of their projects. Here, Martin Wieland discusses the many factors which could impact on the useful life of a dam*

---

Similar to other major infrastructure projects, the design life-span of the dam body is given as a time-span varying between the concession period and typically 100 years. However, the life-span of hydromechanical steel structures, electromechanical equipment and control units is shorter than that of the main civil/structural components and are specified by the suppliers, who also provide instruction manuals describing operation and maintenance. For the civil parts of a water storage facility, however, there are often no manuals on maintenance, although there may be guidelines on regular visual inspections and dam monitoring.

It has to be recognized that there is a direct relationship between dam safety and its life-span, i.e. if the dam is unsafe its life-span has expired.

## **Safety criteria for assessment of the life-span of dams**

The life-span of any dam is as long as it is technically safe and operable! In view of the high damage potential of large storage dams, the safety has to be assessed based on an integral safety concept, which includes the following elements (Wieland and Mueller, 2009):

- 1. Structural safety (main elements: geologic, hydraulic and seismic design criteria; design criteria and methods of analysis may have to be updated when new data are available or new recommendations, guidelines, regulations or codes are introduced).
- 2. Safety monitoring (main elements: dam instrumentation, periodic safety assessments by dam experts, etc.).
- 3. Operational safety (main elements: reliable rule curves for reservoir operation under normal and extraordinary (hydrological) conditions, training of personnel, dam maintenance, sediment flushing, engineering back-up etc.).
- 4. Emergency planning (main elements: emergency action plans, water alarm systems, evacuation plans, engineering back-up etc.).

Therefore, as long as the proper handling of these safety issues can be guaranteed according to this integral safety concept, a dam can be considered as safe.

With the number of people living in the downstream area of a dam and the economic development the risk pattern may change with time, calling for higher safety standards to be applied to the project.

## **Factors affecting life-span of dams**

The main factors, which have an impact on the service life and which may call for upgrading of a dam are the following:

- (i) Changes in the design criteria (hydrology and seismic hazard) based on new information obtained since the initial design of the dam.
- (ii) Changes in methods of analysis and new safety concepts (for example, n-1 rule for flood discharge facilities of embankment dams).

- (iii) Results of risk assessments (new risks and change in risk acceptance criteria).
- (iv) Ageing of construction and foundation materials and components.

As any changes in the above items are reviewed periodically (e.g. during detailed five-year-inspections of large dams), effects such as climatic change on floods etc. can be taken care of. As a matter of fact, this has been done and is being done for other hazards, such as earthquake action, which has not been considered at all in the design of older dams. To adapt an old dam to new seismic design and flood safety criteria is often more drastic than the rather long-term changes in the floods.

### **Ageing and its impact on the life-span of concrete dams**

One of the important safety concerns is ageing of the concrete and of the foundation rock, i.e.

- (i) Chemical processes (swelling due to alkali aggregate reactivity (AAR), sulphate attack, leaching (Figure 1), etc).
- (ii) Physical and mechanical processes (thawing-freezing and drying-wetting cycles, cracking due to seismic actions or non-uniform foundation movements etc).
- (iii) Biological processes (growth of plants in cracks, mussels etc).
- (iii) Seepage in the foundation and the dam body (dissolution of material, weakening of conglomerate, change in uplift of the dam and the foundation resulting in changes in the stability of the dam and abutment).

The ageing processes have to be followed by periodic visual inspections, tests and by monitoring of the dam, but not everything is visible or measurable.

Dense frost-resistant concrete should have a very long service life. Concrete dams, which do not have any steel reinforcement, have a much longer service life than reinforced concrete structures exposed to weather. The oldest concrete dams are about 120 years old. Masonry dams can be much older and still be in service. However, these are usually low structures used in irrigation projects or for water supply.

An extrapolation of concrete performance to 150 or 200 years is rather difficult as no reference projects exist. However, engineers have studied concrete mixes which would guarantee a very long life.

A service life of up to 1000 years would be possible for concrete structures made of special (low-heat) cements and stable aggregates and without steel reinforcement. It is obvious that under ideal environmental conditions (temperature, humidity etc.) the life-span of a concrete dam can be very long. But at the same time, it can also be very short if some of the safety-relevant elements are no longer functioning properly.

An example for uncontrolled safety decrease is the 272m high Enguri arch dam (the world's highest arch dam) in Georgia, which was completed in 1984. Due to civil war in the 1990s, dam safety monitoring (cables and equipment were removed), dam maintenance and emergency plans no longer worked and within a few years it was not clear if the dam was still safe or not (Figure 2). Gates of bottom outlets were leaking, and due to a deficient grout curtain and the failure of pumps used for removing the drainage water, uplift pressure increased. Since then the safety of the dam has been re-established and a new dam monitoring system has been installed.

Due to the many factors affecting the operational condition and environment of a dam, it is not possible to give a number for the remaining service life of existing dams. This has to be assessed periodically on a case-by-case study. Quite a few concrete dams may, however, require major rehabilitation, especially those showing signs of abnormal behaviour or AAR. Also,



uncontrolled sedimentation may shorten the use of the reservoir and may block intakes but does not have a serious effect on the safety of the dam structure or its life-span as long as bottom outlets and spillway gates can still be operated properly. But sediment flushing can cause serious erosion in bottom outlets and sediment flushing tunnels, and sediments can damage turbines within a short period of time.

### **Life-span of dams and components**

The service life of a well-designed, well-constructed and well-maintained and monitored embankment and concrete dams can easily reach 100 years. Hydromechanical elements such as gates and their motors have to be replaced after 30 to 50 years. The life-span of penstocks is 40 to 60 years (Figure 3).

The service life of electro-mechanical equipment varies from 20 to 60 years (Table 1) and electronic control units and software may have to be exchanged as frequently as office computers as they may become technologically outdated and maintenance may no longer be available.

A summary of service lives of structural elements and components of different hydro power plants are given by Giesecke and Mosonyi (2005).

### **Ageing and its impact on the life-span of embankment dams**

Embankment dams are engineered structures using mostly natural materials, part of which may be processed (e.g. filters). In dams with upstream impervious facings, concrete or asphaltic concrete is used. In concrete face rockfill dams (CFRDs) cracking of the face slab is a problem as this leads to undesired seepage losses and accelerated corrosion of the steel reinforcement (Figure 4).

The life-span of a reinforced concrete face slab element is definitely shorter than that of a riprap of reasonably strong rockfill. Therefore CFRDs may need more maintenance than a conventional rockfill dam with impervious core.

Asphaltic concrete and geotextiles are sensitive to ultraviolet rays which cause brittleness of the material leading to cracks and finally to its ultimate disintegration.

Ageing also affects the foundation of a dam. With embankment dams these ageing processes can be more critical than with concrete dams because they are often founded on alluvial deposits or residual soils. Water flow through the foundation can result in strength changes over time. Particularly sensitive are clayey materials, but also rocks may reduce their strength. Water flow through the foundation can affect foundation permeability, dissolution of soluble rock, and leaching of grout curtains. Finally, seepage may wash out infilled joints or cause erosion in the soils of the foundation (especially with dispersive soils) leading to the formation of 'pipes'. All these processes are usually very slow and only develop over a time span of many years.

The foundation is as essential for the life-span of the dam structure as the structure itself. Maintenance of a foundation is by providing it with supplementary treatment, for example by reinforcing or extending the grout curtain or by replacing it with a positive or semi-positive cutoff, by installing relief wells or any other means of drainage depending on the actual situation and its requirements.

Properly designed and constructed embankment dams can remain structurally stable and safe for centuries as long as they are not subjected to erosion processes. There are also a few landslide dams, which have blocked valleys for many years and remained stable, such as the 650m high Usoy dam in Tajikistan, which was formed by a massive landslide triggered by a magnitude 7.3 earthquake in 1911

Embankment dams are most vulnerable to floods (Figure 5), internal erosion and seismic loading. However, a well-designed and maintained embankment dam is a very resilient structure and can also sustain extreme loading

conditions. However, periodic safety assessments are indispensable as they will show what measures have to be taken to maintain or even extend the life-span. Deficiencies observed after commissioning must be rectified as early as possible.

### Conclusions

The life-span of a dam is as long as proper maintenance can be guaranteed. This statement does not capture all aspects of safety, but it clearly indicates that a dam, which is safe at the time of completion, does not automatically remain safe. Unfortunately, quite a few dam owners still believe that a dam, which was safe at the time of its completion, will always remain safe. Some of them even abandon monitoring of the dam structure if instrumental data have remained the same for several years. Neglecting civil maintenance will unequivocally lead to a shortened life-span, which signifies an economic loss, and in a loss of confidence in the safety of dams by the affected people. Maintenance of the electro-mechanical and hydromechanical components is more common than civil maintenance as component failure and corrosion are more common phenomena, which have direct consequences, e.g. on the operation of the power plant. In the large dam structures internal deterioration and deficiencies are often not as readily visible as in the usually accessible hydromechanical and electro-mechanical components.

In some cases the economical life of a storage project may be governed by other factors such as siltation of the reservoir, etc.

*Martin Wieland, Chairman, icold Committee on Seismic Aspects of Dam Design; c/o Pöyry Energy Ltd., Hardturmstrasse 161, P.O. Box, CH-8037 Zurich, Switzerland, E-mail: martin.wieland@poyry.com*

Tables

Table 1



Figure 3a



Figure 3b



Figure 2a



Figure 5b



Figure 4



Figure 2b



Figure 1



Figure 5a

[International Water Power](#) is a product of Progressive Media International. Registered office: 40-42 Hatton Garden, London, England, EC1N 8EB. ♦ 2022, All Rights Reserved.

[Privacy Policy](#)

We have updated our [privacy policy](#). In the latest update it explains what cookies are and how we use them on our site. To learn more about cookies and their benefits, please view our [privacy policy](#). Please be aware that parts of this site will not function correctly if you disable cookies. By continuing to use this site, you consent to our use of cookies in accordance with our [privacy policy](#) unless you have disabled them.

I have seen this message



## **Appendix G**

**Safe Yield and Drought Resiliency Evaluation, dated May 31, 2019,  
prepared by Tighe & Bond**



## RWA Reservoir Safe Yield and Drought Resiliency Evaluation

**To:** John Hudak  
**FROM:** Peter Galant – Tighe & Bond  
 Steve Nebiker, Casey Caldwell - Hydrologics  
**DATE:** May 31, 2019

This memorandum presents a summary of work done to evaluate the safe yield and drought resiliency of Regional Water Authority's (RWA's) reservoir systems, and the impact of the impending reservoir release requirements of DEEP's Streamflow Standards and Regulations on both. The benefit of the Lake Whitney supply is also considered.

### 1 Background

#### 1.1 Sources of Supply

As summarized in Table 1, RWA's system is supplied by a combination of four active surface water systems and seven active wellfields.

**Table 1**  
 Summary of Supply Sources

Supply Systems	Sources	Safe Yield <sup>1</sup> (mgd)	Available Water (mgd)
North Branford Reservoirs	Lake Gaillard	35.0	35.0
	Lake Menunketuc		
	Lake Hammonasset		
	Stream Diversions		
Mill River Reservoir	Lake Whitney	13.1	13.1
West River Reservoirs	Lake Bethany	10.3	9.2 <sup>2</sup>
	Lake Dawson		
	Lake Watrous		
	Lake Glen		
Saltonstall Reservoirs	Lake Chamberlain	7.9 <sup>3</sup>	7.9
	Lake Saltonstall Farm River Diversion		
Wellfields	North Cheshire	14.9	11.5 <sup>4</sup>
	South Cheshire		
	North Sleeping Giant		
	South Sleeping Giant		
	Mt. Carmel		
	Derby		
	Seymour		
<b>Total:</b>		<b>81.2</b>	<b>76.7</b>

1. RWA 2009 Water Supply Plan.
2. Available water limited by West River WTP.
3. Adjusted from original 1989 Safe Yield to account for Furnace Pond.
4. Available water limited by hydraulic restrictions.

The safe yield of a source of supply, as defined by the CT Department of Public Health (DPH), is the maximum amount of water that can be provided by a source of supply during a critical dry period. For reservoirs, safe yield is calculated as the annual average supply that can be provided during a 1 in 100 year drought. Approximately 82% of RWA's safe yield and 85% of its available water is provided by its reservoir systems.

## 1.2 Margin-of-Safety

Margin-of-Safety (MOS) is the unitless ratio of available water to demand. An MOS greater than 1.0 means that a system has more supply than demand, and an MOS less than 1.0 indicates a supply deficiency. There is no regulatory standard for MOS, however DPH requires that it be calculated for annual average, maximum month, and maximum day demand conditions and sets a target MOS of 1.15 (15%) for each. For reservoirs, annual average supply is typically limited by safe yield and maximum month and maximum day supplies are limited by treatment capacity. This report therefore focuses on RWA's average day MOS.

RWA's average daily demand from 2014 – 2018 was 45 mgd. Compared to the 76.7 mgd available water recent demands result in a margin-of-safety of 1.70. Excluding the potential loss of available water from the impending DEEP Streamflow Regulation release requirements, RWA's demands could maintain a minimum margin-of-safety of 1.15 with demands up to 66.7 mgd.

## 1.3 Drought Plan

As required by regulation, RWA has a four-stage drought response plan intended to improve system reliability by reducing customer demand during drought conditions. Because RWA's system is predominantly reservoir supplied, and because reservoirs are typically more impacted by drought than groundwater supplies, the stages of RWA's drought response plan are triggered by the amount of storage available in its reservoirs. Table 2 summarizes target demand reductions for each drought stage and Figure 1 presents RWA's triggers for each stage.

**Table 2**  
Drought Stages

Stage	Type of Restrictions	Target Demand Reduction
Advisory	Voluntary	10%
Watch	Voluntary	15%
Warning	Mandatory	20%
Emergency	Mandatory	25%



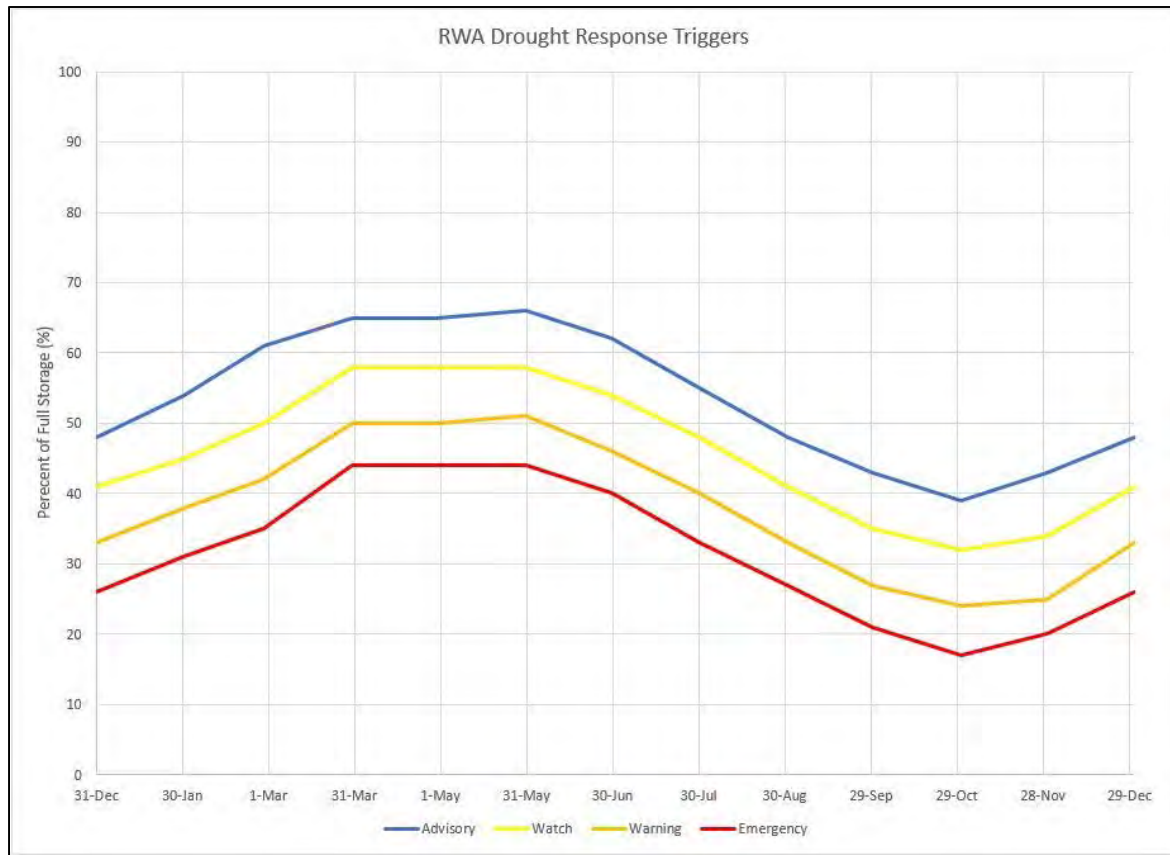

**Figure 1 - Drought Response Triggers**

### 1.4 Stream Flow Standards and Regulations

In December 2011 the Department of Energy and Environmental Protection (DEEP) issued its final Stream Flow Standards and Regulations (RCSA 26-141b) that require minimum releases from all dams to maintain ecologically protective flows downstream. The regulations set release requirements based on the classification of the stream below the dam. There are four stream classes, with Class 1 being the least flow altered and Class 4 being the most flow altered. Streams below public water supply dams cannot be Class 1 or Class 2. Classification of streams in the South Central Coastal Basin, that includes RWA’s active reservoirs, was completed in September 2016. The streams below RWA’s active supply dams are all Class 3, with the exception of Lake Glen being Class 4. Releases are required to start within 10 years of the final classification of the stream below a dam, or by September 2026 for RWA’s dams.

For small reservoirs (<3 square miles of watershed or <100 MG of usable storage) and dams one and a half miles or less upstream of another impoundment, the required Class 3 release is the same throughout the year and is equal to the lesser of reservoir inflow, or a calculated natural low flow statistic for the stream called the Rearing and Growth Bioperiod Q80 (R&GBQ80), determined using USGS’s online StreamStats application, or methods otherwise acceptable to DEEP. For most large reservoirs, the required Class 3 release varies seasonally based on seasonal natural low flow statistics.

If the R&GBQ80 at a dam is less than 0.1 cfs (0.065 mgd) then no releases are required. This is the case with Lake Chamberlain, Lake Glen, and several small diversion dams in the North Branford system. Releases are also not required for certain dams subject to a flow

management plan, like the Whitney Environmental Management Plan, and dams at the base of which the waters are tidally-influenced, like Lake Saltonstall.

Table 3 presents a summary of the anticipated release requirements at RWA's dams.

<b>Table 3</b>							
Required Release Rates							
Dam	Dec.– Feb.	March– April	May	June	July – October		November
					Dry	Wet	
<b>Required Release Rates (cfs)</b>							
Bethany	0.45	0.45	0.45	0.45	0.45	0.45	0.45
Watrous	0.79	0.79	0.79	0.79	0.79	0.79	0.79
Menunketuc	0.88	1.94	1.24	0.40	0.15	0.52	0.68
Iron Stream	0.23	0.23	0.23	0.23	0.23	0.23	0.23
Dawson	3.28	9.74	7.83	3.23	1.41	3.59	3.70
Hammonasset	5.81	14.90	12.90	5.81	2.64	6.05	6.24
Farm River East Haven	2.76	2.76	2.76	2.76	2.76	2.76	2.76
Gaillard	1.76	3.54	2.04	0.60	0.24	0.91	1.17
Farm River North Branford <sup>1</sup>	1.4	1.4	1.4	1.4	1.4	1.4	0.33
<b>Required Release Rates (mgd)</b>							
Bethany	0.291	0.291	0.291	0.291	0.291	0.291	0.291
Watrous	0.511	0.511	0.511	0.511	0.511	0.511	0.511
Menunketuc	0.569	1.254	0.801	0.259	0.097	0.336	0.439
Iron Stream	0.149	0.149	0.149	0.149	0.149	0.149	0.149
Dawson	2.120	6.295	5.060	2.087	0.911	2.320	2.391
Hammonasset	3.755	9.629	8.337	3.755	1.706	3.910	4.033
Farm River East Haven	1.784	1.784	1.784	1.784	1.784	1.784	1.784
Gaillard	1.137	2.288	1.318	0.388	0.155	0.588	0.756
Farm River North Branford <sup>1</sup>	0.905	0.905	0.905	0.905	0.905	0.905	0.905

1. Riparian agreement release (shown) is greater than required by streamflow regulations.

Regardless of reservoir size, the required release can be reduced as a water system hits each stage of its approved drought response plan. The allowed reductions are 25% at Drought Advisory (except in the summer), 50% at Drought Watch, 75% at Drought Warning and 100% at Drought Emergency. This provision provides significant public water supply protection, and also importantly means that reservoir safe yield will be dependent on the water system's drought response triggers.

## 2 Existing Conditions

The first step in the evaluation was to create a mass balance reservoir operations model of RWA's reservoir systems utilizing Hydrologics' proprietary OASIS software. The model utilizes RWA's reservoir characteristics (e.g. watershed size, stage/storage relationship), local precipitation data for direct rainfall on the reservoir, DPH evaporation rates, reservoir release requirements, current monthly demands and RWA operating rules for transferring water

between reservoirs. Reservoir inflow was based on adjusted USGS Stream Gage data, validated based on recent reservoir performance. Figure 2 compares modeled to historic reservoir storage for RWA’s combined reservoirs and demonstrates the strong model validation that was achieved. The model validation was similarly evaluated for each individual reservoir system.

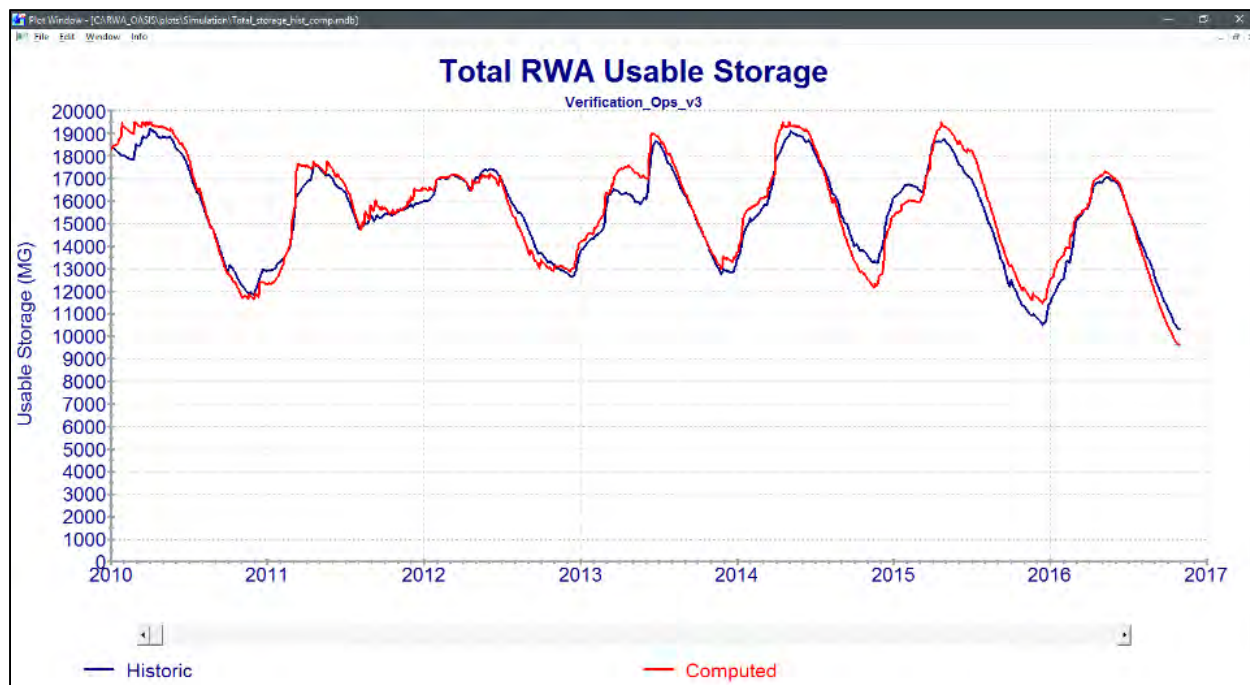

**Figure 2 Reservoir Model Validation**

## 2.1 Safe Yield

The validated OASIS model was utilized to determine the safe yield of each of RWA’s reservoir systems in accordance with the procedures defined in the DPH regulations (RCSA 25-32d-5). Because operations of the North Branford and Lake Whitney systems are closely related a combined safe yield was determined for those two reservoir systems. Table 4 compares the resulting 1 in 100 year safe yield determinations with the original determinations performed in 1989 and used in RWA’s current water supply planning.

**Table 4**  
Safe Yield – Existing Conditions

<b>Reservoir System</b>	<b>1989 Safe Yield (mgd)</b>	<b>2019 Safe Yield (mgd)</b>
North Branford/Whitney	48.1	47.3
West River	10.3	11.6
Saltonstall	7.9 <sup>1</sup>	9.2
<b>Total:</b>	<b>66.3</b>	<b>68.1</b>

1. Updated to include Furnace Pond

As indicated, the updated analyses result in an increase in RWA’s total reservoir safe yield of 1.8 mgd (3%). The primary differences between the 1989 and 2019 studies were:

- Changed the stream gage used for estimating inflows to the West River, Mill River and Lake Saltonstall Reservoirs to obtain improved model validation.

- Increased usable storage in Lake Saltonstall based on 2004 bathymetric survey.
- Updated monthly demand patterns for each reservoir.
- Included the final Lake Whitney operating rules based on the Lake Whitney Environmental Management Plan.
- Conservatively used historical inflows rather than adjusting them upward to estimate 1 in 100 year return frequency.

Based on this updated analysis, the RWA's current total average day available water, including groundwater sources, is 77.2 mgd. This accounts for operational limitations for the West River Water Treatment Plant (9.2 mgd) and the New Haven service area wellfields, as described in the RWA's 2009 Water Supply Plan. Based on the average day demand from 2014 – 2018 of 45 mgd, this results in a margin-of-safety of 1.72.

## 2.2 Drought Resilience

Although margin-of-safety is the most common measure of supply adequacy in Connecticut, recent experience has demonstrated that drought resiliency is also an important consideration. Reservoir supplied systems with adequate margin-of-safety can still experience uncomfortably low reservoir storage during times of low flow and high demand.

To evaluate the susceptibility of RWA's system to drought the OASIS model was used to simulate reservoir performance over the historic period of record for which USGS stream gage and precipitation data were available, utilizing current system demands and reservoir operating rules. Figure 3 presents the resulting modelled total system storage in comparison to RWA's drought triggers.

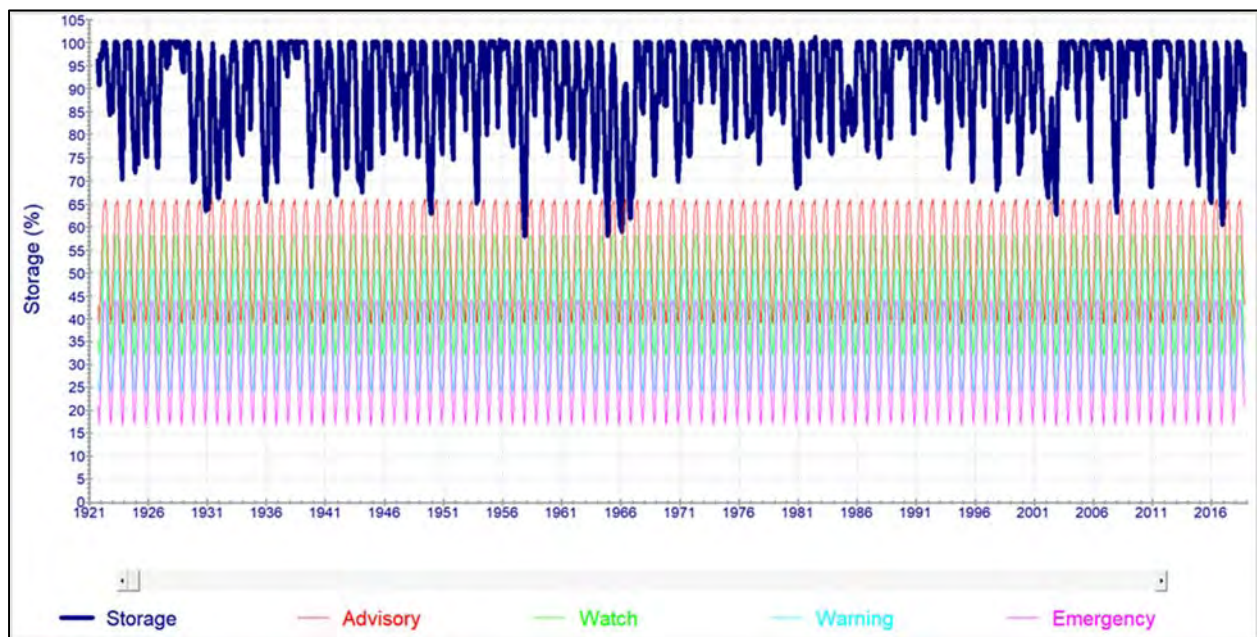

**Figure 3 Reservoir Drawdown Under Current Conditions**

The minimum storage that RWA's reservoir system would have reached over the almost 100 years modeled under current demands and operations was 58%, in 1957. In addition, the model simulated no occurrences of any drought stages over this time period. This analysis indicates that RWA's reservoir system is currently at low risk for significant drought impact when fully utilized.

### 3 Impact of Streamflow Regulations

The safe yield and drought resiliency analyses presented above were repeated considering the need to make reservoir releases in compliance with the streamflow regulations beginning in September 2026.

#### 3.1 Safe Yield

Table 5 presents the impact of the Streamflow Regulation release requirements on RWA's reservoir safe yield in comparison to the 1989 yield used in RWA's Water Supply Plan and the 2019 safe yield presented above.

**Table 5**  
Safe Yield – With Streamflow Regulation Releases

Reservoir System	Current Releases		New Releases
	1989 Safe Yield (mgd)	2019 Safe Yield (mgd)	Safe Yield (mgd)
North Branford/Whitney	48.1	47.3	42.8
West River	10.3	11.6	10.3
Saltonstall	7.9 <sup>1</sup>	9.2	9.2
<b>Total:</b>	<b>66.3</b>	<b>68.1</b>	<b>62.3</b>

1. Updated to include Furnace Pond

The release requirements of the DEEP Streamflow Regulations will result in a 5.8 mgd (8.5%) loss of safe yield in RWA's reservoirs.

The loss in safe yield due to the Streamflow Regulations is partially mitigated from a planning perspective because the 1989 reservoir safe yield that has historically been used for planning is lower than the updated 2019 safe yield, and because available water in the West River system is limited to 9.2 mgd by West River Water Treatment Plant operations even after the new streamflow release requirements are in place. Total available water, including groundwater sources, after implementation of the streamflow releases is expected to be 72.7 mgd. Compared to 2014-2018 demands this results in a margin-of-safety of 1.62. After implementation of the release requirements from DEEP's new Streamflow Regulations, RWA's demands could maintain a minimum margin-of-safety of 1.15 with demands up to 63.2 mgd.

#### 3.2 Drought Resilience

Figure 4 presents the modelled total reservoir storage over the period of available records utilizing current demands and operations and reservoir releases in compliance with the new DEEP Stream Flow Regulations.

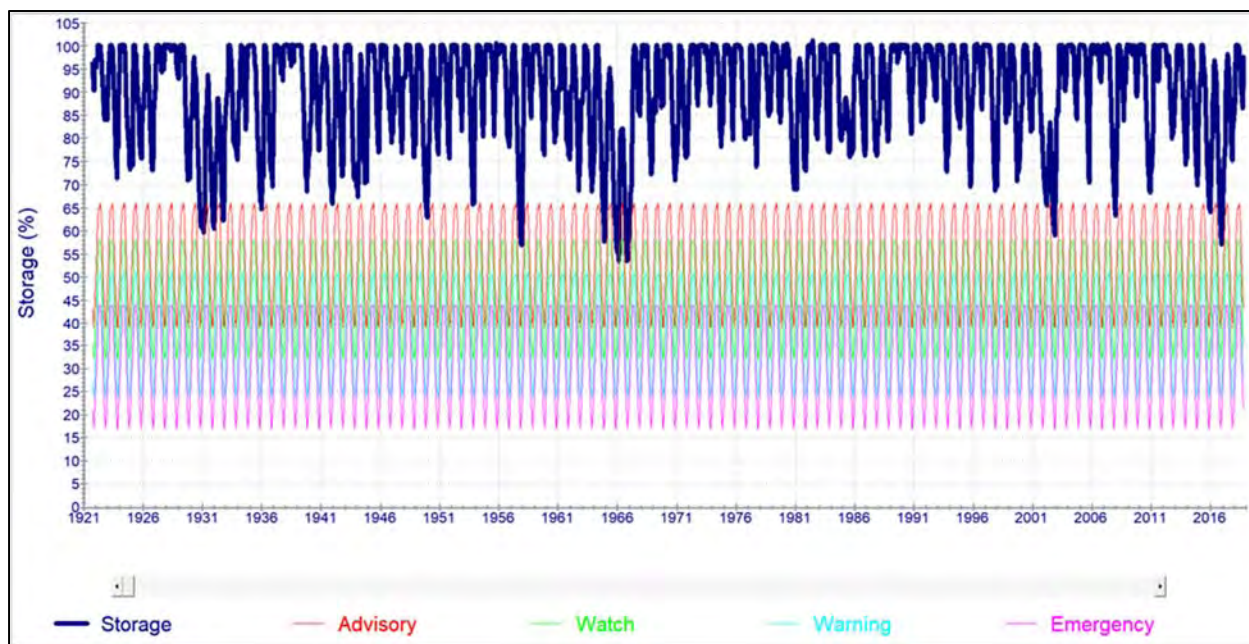

**Figure 4 - Reservoir Drawdown With New Stream Flow Regulation Releases**

The minimum storage that RWA’s reservoir system would have reached over the almost 100 years modeled under current demands and operations would have been 54%, in 1966. In addition, the model simulated no occurrences of any drought stages over this time period. This analysis indicates that the RWA’s reservoir system, when fully utilized, will remain at low risk for significant drought impact after implementation of the Stream Flow Regulation release requirements.

## 4 Impact of Lake Whitney

The Lake Whitney Water Treatment Plant is expensive to operate and runs with complex operating rules that limit its available water. This section of the memorandum summarizes an analysis of the impacts of not using the Lake Whitney supply on RWA’s safe yield and drought resiliency. It is not RWA’s intent to eliminate this supply, but the analysis illustrates the magnitude of the supply’s impact on system reliability. The analysis compares 2019 conditions (updated safe yield) under current and future reservoir release requirements.

### 4.1 Safe Yield

Table 6 presents RWA’s reservoir safe yield with and without Lake Whitney under the two release scenarios.

**Table 6**  
Safe Yield – With and Without Lake Whitney (mgd)

Reservoir System	Current Releases		New Releases	
	With Whitney	Without Whitney	With Whitney	Without Whitney
North Branford/Whitney	47.3	36.7	42.8	31.8
West River	11.6	11.6	10.3	10.3
Saltonstall	9.2	9.2	9.2	9.2
<b>Total:</b>	<b>68.1</b>	<b>57.5</b>	<b>62.3</b>	<b>51.3</b>

As indicated, if Lake Whitney were inactive it would reduce RWA's reservoir safe yield by 10.6 mgd (16%) under current release requirements and 11 mgd (18%) after implementation of the Streamflow Regulation release requirements. The system's margin-of-safety compared to 2014-2018 demands would be reduced to 1.48 under current release requirements and 1.37 after implementation of the Streamflow Regulation release requirements and the average day demand that could be supplied with a 1.15 margin-of-safety would be 57.9 mgd under current release requirements and 53.7 mgd after implementation of the new releases.

### 4.2 Drought Resilience

Figures 5 and 6 illustrate the impact of not using Lake Whitney on total reservoir storage under current demands as modeled from 1921 through 2017.

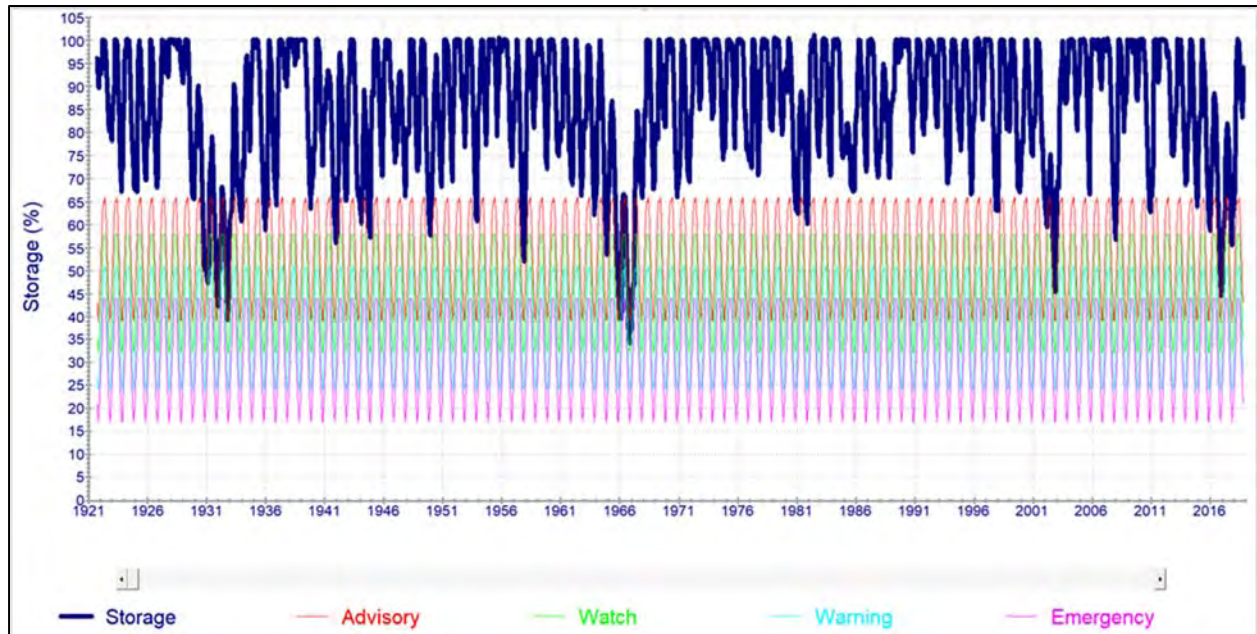

**Figure 5 Reservoir Drawdown Under Current Conditions and w/o Lake Whitney**

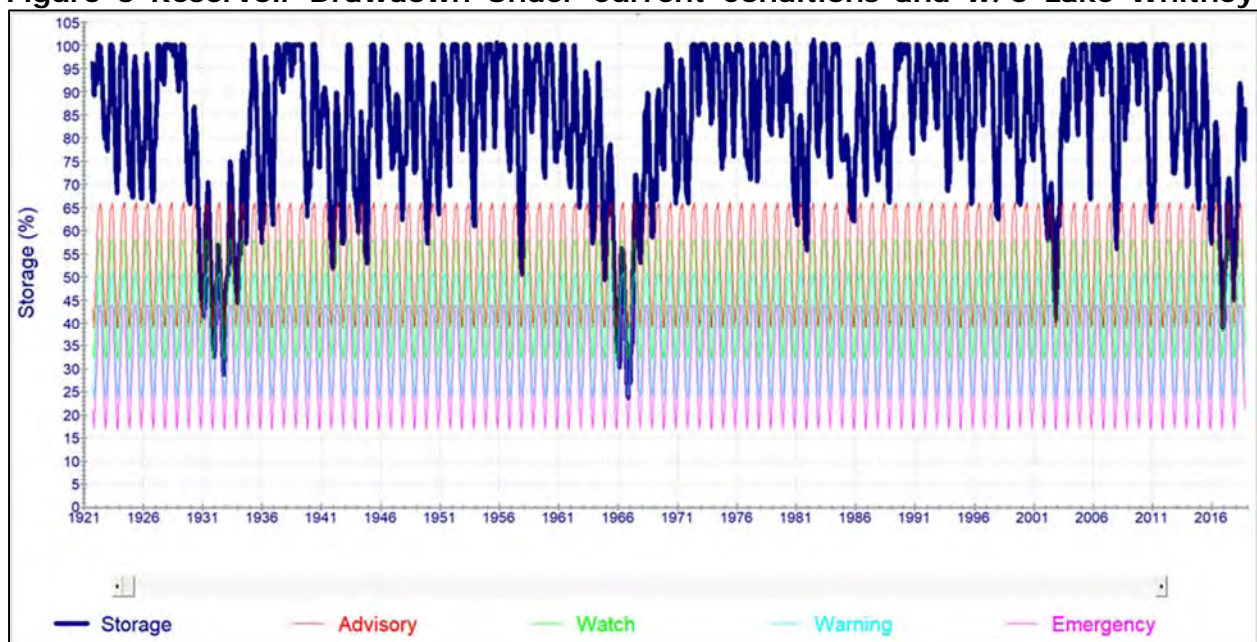

**Figure 6 – Reservoir Drawdown with new Streamflow Regulation Releases and w/o Lake Whitney**

The minimum system storage without Lake Whitney would have been 34% under current release requirements and 24% under future Stream Flow Regulation release requirements, both in 1966. Minimum storage in the North Branford Reservoir System, which would need to increase production to offset the lost production from Lake Whitney, would have been 22% under current releases and 6% under future releases. In addition, without Lake Whitney the model predicts that RWA's system would have experienced five Drought Advisories, three of which would have become Drought Watches, over the nearly 100 years simulated under current demands and release requirements. With the future Streamflow Regulations release requirements this drought frequency would have increased to six Drought Advisories, four of which extend through Watch, Warning and into Emergency, over the period simulated.

## Summary and Conclusions

Table 7 summarizes the impact of the new release requirements on RWA's available supply with Lake Whitney active. As shown, the RWA System has adequate supply to meet demands under both current and future Stream Flow Regulation release scenarios.

**Table 7**  
Summary of Release Impacts

Parameter	Current Releases	New Releases	Difference
Reservoir Safe Yield (mgd)	68.1	62.3	5.8 (8.5%)
Total Available Water - Reservoirs (mgd)	65.7	61.2	4.5 (6.8%)
Total Available Water - Reservoirs & Wells (mgd)	77.2	72.7	4.5 (5.8%)
Margin of Safety with Recent Demand <sup>1</sup>	1.72	1.62	0.10 (5.8%)
Demand That Can be Supplied at MOS = 1.15 (mgd)	67.1	63.2	3.9 (5.8%)

1. 2014 – 2018 = 45 mgd

The results presented in this memorandum also indicate that RWA's drought triggers are adequately protective and do not need to be modified.

If the Lake Whitney supply were to be removed from service, the adequacy of RWA's supply would be reduced and the drought risk would increase significantly. As a next step it is recommended that RWA consider developing revised operating rules for Lake Whitney that balance the desire to reduce overall production costs with the need to maintain a reliable public water supply.



# **Appendix I**

**Conceptual Project Cost Summary, dated April 8, 2022, prepared by  
GZA**



**CONCEPTUAL PROJECT COST SUMMARY  
LAKE WHITNEY DAM  
HAMDEN, CT**

Date of Estimate	Concept Rehabilitation	Construction Cost Estimate						Engineering, Permitting, and Owner's Cost During Construction <sup>10</sup>		Total Estimated Construction Cost with Contingency (2021) <sup>11</sup>	
		General Conditions	Water Control	Structural Dam Improvements (Spillway and Non-Overflow)	Overtopping and Scour Improvements	Ancillary Structures (Intake + Blowoff)	Estimated Construction Cost Subtotal	Estimated Engineering During Construction	RWA Cost During Construction	Assumed Construction Contingency	Total Estimated Cost with Const. Contingency
1/11/2022	UPSTREAM CONCRETE MASS WITH GROUTING EXISTING MASONRY - January 11, 2022 - Pre RWA Review Changes	\$2,775,000	\$15,500,000	\$15,900,000	\$900,000	\$800,000	\$35,875,000	\$3,587,500	\$2,535,000	20%	\$50,000,000
2/9/2022	UPSTREAM CONCRETE MASS WITH GROUTING EXISTING MASONRY - January 28, 2022 - Post RWA Review Changes	\$2,775,000	\$12,400,000	\$15,600,000	\$900,000	\$800,000	\$32,475,000	\$3,247,500	\$2,535,000	20%	\$45,000,000
2/9/2022	NEW CONCRETE DAM	\$2,800,000	\$14,500,000	\$20,800,000	\$1,000,000	\$800,000	\$39,900,000	\$3,990,000	\$2,535,000	20%	\$55,000,000
2/9/2022	GROUTED MASONRY WITH UPSTREAM GROUND IMPROVEMENT	\$3,675,000	\$2,550,000	\$19,900,000	\$1,300,000	\$2,100,000	\$29,525,000	\$2,952,500	\$2,535,000	30%	\$44,000,000
2/9/2022	GROUTED MASONRY WITH TIE-DOWN ANCHORS	\$3,550,000	\$2,550,000	\$16,800,000	\$900,000	\$2,100,000	\$25,900,000	\$2,590,000	\$2,535,000	30%	\$39,000,000
4/8/2022	DOWNSTREAM BUTTRESS- OVERFLOW AND NON-OVERFLOW	\$2,550,000	\$2,800,000 to \$3,050,000	\$13,825,000 to \$14,325,000	\$900,000	\$2,100,000	\$22,175,000 to \$22,925,000	\$2,217,500 to \$2,292,500	\$2,535,000	30%	\$34,000,000 to \$35,000,000

ENGINEERING DESIGN AND GRANTS COSTS			
Project Spend to Date Design	Project Cost to Finish Design	WIFIA Application	Total Estimated Costs for Engineering Design and Grants
\$1,700,000	\$600,000	\$300,000	\$2,600,000
\$1,700,000	\$600,000	\$300,000	\$2,600,000
\$1,700,000	\$1,000,000	\$300,000	\$3,000,000
\$1,700,000	\$1,000,000	\$300,000	\$3,000,000
\$1,700,000	\$1,000,000	\$300,000	\$3,000,000
\$1,700,000	\$1,250,000	\$300,000	\$3,250,000

TOTAL ESTIMATED PROJECT COST W/O ADD/ALT OPTIONS	
Total Estimated Project Cost in 2021	Total Estimated Project Cost in 2025
\$52,600,000	\$58,300,000
\$47,600,000	\$52,800,000
\$58,000,000	\$64,300,000
\$47,000,000	\$52,100,000
\$42,000,000	\$46,600,000
\$37,250,000 to \$38,250,000	\$41,300,000 to \$42,400,000

**NOTES:**

- Refer to Concept Cost Estimate Breakdown Tab for additional details of estimated cost
- General Conditions includes: General Provisions, ACOE In-Lieu Fee + SHPO Reconciliation
- Water Control includes: Cofferdam/Water Control Measures, Reservoir Bypass System, Temporary Concrete Notch (if required), Emergency Demobilization
- Structural Dam Improvements includes: Earthwork, Non-Overflow Improvements, Masonry Grouting and Spillway Improvements
- Overtopping and Scour Improvements includes: Overtopping Protection- ACBs and Plunge Pool and Downstream Improvements
- Ancillary Structures includes: Blowoff Valve Extension and Rehab of Intake Structures
- Engineering During Construction assumes 10% of Construction Cost
- Upstream Concrete Mass alternatives based on 45% design submission with modifications based on Project Team conference calls
- New Concrete Dam, Grouted Masonry with Upstream Ground Improvement, Grouted Masonry with Tie-Down Anchors, and Downstream Buttress based on concept-level drawings/evaluations only, no design or detailed evaluations were performed.
- Assumed contingency was applied to the estimated construction costs only and not to the Estimated Engineering Costs During Construction or RWA's Cost During Construction
- The February 9, 2022 Conceptual Project Cost Summary was revised to add Downstream Buttress Concept.
- Several conceptual level assumptions/allowances were developed to generate the cost estimate for the downstream buttress alternative. These allowances include utility relocation, modifications to existing d/s structures, and additional water control/dewatering from d/s spillway improvements. The actual costs will change during the design development.
- Additional \$250K added to Downstream Buttress engineering as an allowance for public meetings, PAL involvement, conference calls and mockups.
- Downstream buttress concrete volume was based on the volume of concrete required for the upstream concrete mass alternative. No engineering performed to confirm required concrete volumes.

DATE: April 8, 2022



## **Appendix K**

**Lake Whitney Hydropower Assessment & Funding Memorandum,  
dated November 27, 2019, prepared by GZA.**





Proactive by Design

GEOTECHNICAL  
ENVIRONMENTAL  
ECOLOGICAL  
WATER  
CONSTRUCTION  
MANAGEMENT



## MEMORANDUM

To: Mr. Orville Kelly, Capital Construction Lead (South Central Connecticut Regional Water Authority)

From: Christine H. Stonier, P.E., Todd E. Monson, P.E., Matthew A. Taylor, P.E. & Chad W. Cox, P.E.<sup>MA</sup> (GZA GeoEnvironmental, Inc)

Date: November 27, 2019

File No.: 01.0174183.00

Re: Lake Whitney Hydropower Assessment & Funding Memorandum

---

GZA GeoEnvironmental, Inc (GZA) has been engaged by South Central Connecticut Regional Water Authority (SCCRWA) to perform a preliminary hydropower feasibility assessment at the Lake Whitney Dam located in Hamden, CT. This memorandum was prepared in accordance with the Agreement for Professional Services Accepted on April 1st, 2019, Appendix 1 - Scope of Work, and discussions held during conference calls on July 16, 2019, October 11, 2019 and November 8, 2019 conference call. This memorandum is subject to the Limitations in **Attachment A**.

### PURPOSE

The overall purpose of this assessment is to preliminarily evaluate the technical and financial feasibility of modifying the Lake Whitney Dam for the purpose of generating hydroelectric power. The specific objectives of the memorandum are:

- 1) Conduct preliminary conceptual feasibility analyses/assessments of the hydropower generation potential at the site;
- 2) Estimate potential financial returns of possible hydropower generation at the site;
- 3) Identify key Federal Energy Regulatory Commission (FERC) considerations; and
- 4) Identify potential funding for dam reconstruction and hydropower generation.

GZA considered two options for developing a hydroelectric project at the dam:

- 1) Traditional Hydroelectric Project adjacent to the outlet of the 42-inch blow off at the dam; and
- 2) Conduit Hydroelectric Project on a by-pass on the 36-inch raw water line from the reservoir to the Water Treatment Plant (WTP).



## HYDROLOGIC AND HYDRAULIC REVIEW

### OPTION 1 – TRADITIONAL HYDROPOWER – EVALUATION OF AVAILABLE FLOW

#### *GZA Statistical Evaluation of Stream Gage Data*

GZA developed a flow duration curve using United States Geological Survey (USGS) streamflow data to estimate the design flow which will be used to calculate the potential power and energy production at the site. A flow duration curve provides a compact summary of stream flow variability. GZA developed a flow duration curve based on streamflow records from the nearby USGS gage 01196620 Mill River near Hamden, Connecticut, which is located approximately 7.1 miles upstream of Lake Whitney Dam. The period of record for the gage is from December 1968 to May 2019. However, daily flow data is missing from October 1970 through September 1978. The drainage area at USGS Gage 01196620 is approximately 24.5 square miles, whereas, the drainage area to Lake Whitney Dam is approximately 36.4 square miles. Both watersheds have similar levels of development, impervious area, etc. and therefore are considered to be comparable in terms of runoff performance. As a result, GZA elected to use a simple watershed ratio to allow the stream gage data to be used in the model for Lake Whitney Dam.

$$Q_1 = \frac{Q_2 * A_1}{A_2} = Q_2 * 1.49$$

Where:

Q1 = flow at the ungaged point of interest (Lake Whitney Dam) (cfs)

A1 = basin area at the ungaged point of interest (Lake Whitney Dam) (square miles)

Q2 = flow at the stream gage (cfs)

A2 = basin area at the stream gage (square miles)

The flow duration curve for the period of record at USGS gage 01196620 Mill River scaled to the site is included in graphical form as **Figure 1**. Discrete data from the curve is included in tabular form (see Table 1 in Attachment B). The 25-percent exceedance at the Lake Whitney Dam using this methodology is approximately 86 cubic feet per second (cfs). This flow would be inclusive of flows used for the water treatment withdrawal and/or the artificial waterfall.

GZA also developed a flow duration curve using a limited dataset for USGS gage 01196626 (1974 – 1978) located on the Mill River immediately downstream of the Lake Whitney Dam to compare the flow estimate to the upstream USGS gage. The flow duration curve is provided in graphical form as **Figure 1** and discrete data from the curve is included in tabular form (see Table 2 in Attachment B). No adjustment was applied to the flow at this location because the gage was several hundred feet downstream of the Lake Whitney Dam. The flow records from USGS gage 01196620 and USGS gage 01196626 do not overlap, and therefore a daily comparison of the flows was not possible. GZA estimated the 25-percent exceedance at the USGS gage 01196626 to be approximately 106 cfs, which is approximately 23 percent higher than that estimated using the adjusted flow data from USGS gage 01196620 Mill River scaled to the site.

GZA reviewed nearby gage data to evaluate whether the 1974 – 1978 period of record was exceptionally wet in comparison to the full period of record. Due to the limited period of record at this gage, GZA analyzed three additional nearby USGS stream gages (01196500 Quinnipiac River, 01204000 Pomperaug River and 01189000 Pequabuck River) to evaluate whether the 1974 - 1978 period of record was wetter or drier compared to a longer record. Flow duration data for each gage was calculated for the A) full period of record for USGS gage 01196620 Mill River (December 1968 to May 2019, excluding October 1974 through September 1978) and B) the limited period of record for USGS gage 01196626 Mill





River (October 1974 to September 1978). The estimates for the 25-percent exceedance flows are included in Table 3 of Attachment B. On average October 1974 to September 1978 was 9 percent wetter at the 25-percent exceedance than the full period of record when compared to the three nearby gages. Therefore, it is anticipated that using flow duration data from the shorter period of record (USGS gage 01196626 Mill River) would overestimate flows, but likely not by 23%. This suggests that use of a simple watershed ratio may underestimate flows at the Lake Whitney Dam because it does not account for other factors which affect runoff potential of a watershed such as soil conditions, development, percent impervious or storage within the watershed. As a result, GZA evaluated additional methodology to estimate the flow duration data at the site, which is detailed as follows.

#### *GZA Evaluation Based on StreamStats Regression Analysis*

GZA also used the StreamStats online web application developed by the USGS to estimate peak flows to compare to the estimated developed using the stream gage data and simplified watershed ratio. StreamStats provides hydrologic data and annual flow statistics at ungaged locations based on regional regression equations developed by the USGS. Annual 25-percent flow duration statistics are available for the site based on the 2010 *Regional Regression Equations to Estimate Flow-Duration Statistics at Ungaged Stream Sites in Connecticut* report prepared by USGS<sup>1</sup>, and the tool estimates the 25-percent exceedance to be 94 cfs. The StreamStats estimates for the 25-and 99-percent exceedance flows are plotted on **Figure 1** for reference.

#### *Review of Previous Hydropower Feasibility Studies by Others*

In performing our evaluation, GZA also reviewed two previous hydropower feasibility studies performed by others. These evaluations included:

- *Preliminary Screening Study for Additional of Generation* at Lake Whitney Dam - HDR – 2017
- Lake Whitney Dam Hydroelectric Power Generation Feasibility Study Hydropower Study – Roald Haestad -1984

Below is a general summary of those evaluations including how they compared to our evaluation.

#### *GZA's Review of the 2017 HDR Hydropower Evaluation*

*A Preliminary Screening Study for Additional of Generation* at Lake Whitney Dam was prepared by HDR in 2017 (HDR Memo)<sup>2</sup>, which recommended further confirmation of hydrology to estimate flow at the site. GZA reviewed the analysis presented in the HDR Memo and performed additional evaluation of site hydrology to confirm the recommended preliminary design flow for sizing hydropower generation equipment/facilities. It is GZA's understanding that the design flow used by HDR to size hydropower generation at the site was based on spillway flows for the period of 2000 – 2015, estimated by the SCCRWA (Figure 7 in HDR Memo). The flow exceedance curve presented in the memorandum was developed based on measured reservoir elevations and estimated flows calculated using an uncalibrated head-flow rating table provided by SCCRWA from 2000 – 2015. The design flow was reported to be 190 cfs, which is approximately the 25-percent exceedance flow based on the HDR-generated flow duration curve.

<sup>1</sup> Ahearn, E.A., 2010, Regional regression equations to estimate flow-duration statistics at ungaged stream sites in Connecticut: U.S. Geological Survey Scientific Investigations Report 2010–5052, 45 p., at <http://pubs.usgs.gov/sir/2010/5052/>

<sup>2</sup> HDR, Preliminary Screening Study for Addition of Generation Memorandum, January 18, 2017



The 2017 HDR Memo also provided a flow duration curve (Figure 5) for the USGS gage 01196620 Mill River (upstream of the dam). The flow duration curve in the HDR Memo appears to represent streamflow data at the USGS gage and does not appear to adjust the flow to be reported at the site. The data within the HDR Memo was not provided in tabular form, and GZA estimated the values by scaling the Figures. Figure 5 of the HDR Memo shows that the 25-percent exceedance flow at the USGS gage on the Mill River is 60 cfs, which is similar to the unscaled flow at the USGS gage calculated by GZA. GZA notes that the stream gage 25% exceedance flow (60 cfs) gage flow is substantially less than the design flow (190 cfs) selected by HDR based on the 2000 – 2015 flow exceedance data provided by SCCRWA.

For comparison purposes, GZA developed a flow duration curve using the 2000 – 2015 water levels and Rating Table data and provided this curve in **Figure 1**. GZA's developed flow duration curve differs from that presented in Figure 7 of the HDR Memo and estimates a 25-percent exceedance flow of approximately 165 cfs. As indicated above, HDR's value was 190 cfs. It is unclear why GZA and HDR developed different 25% exceedance flow rates given they were supposedly both developed using the same data.

GZA also reviewed the suitability of HDR's approach of using the uncalibrated rating table to estimate the available streamflow at the site. The rating table estimates flows over the spillway using the weir equation ( $Q = CLH^{3/2}$ ), and the weir coefficient varies from 0.25 at 0.01 feet of head over the spillway to 3.6 at 0.6 feet and greater of head. A uniform weir coefficient of 3.6 for depths greater than 0.6 is likely too high based on the existing dam geometry, in GZA's opinion. The spillway is comprised of three sections 1) a 124.25-foot long broad crested weir with a concrete cap, 2) a 57.75-foot long broad crested weir with a concrete cap and downstream concrete buttress, and 3) a 68-foot long ogee side channel. Typically, weir coefficients range from 2.6 – 3.1 for broad crested weirs and 3.2 – 4.1 for ogee crested weirs<sup>3</sup>. A constant weir coefficient of 3.6 across the spillway for head greater than 0.6 feet likely overestimates flows. A greater weir coefficient would not result in overestimation of flows by up to 220%. Therefore, it is GZA's opinion that the HDR rating table likely overestimates available stream flow at the site.

#### GZA's Review of the 1984 Haestad Hydropower Study

GZA reviewed the analysis approach and results detailed within the 1984 Haestad Hydropower Study<sup>4</sup> and compared to our estimated flow duration data. The Haestad Study developed a flow duration curve using limited flow data from a USGS gage 01196626 (1974 – 1978) located on the Mill River immediately downstream of the Lake Whitney Dam. The data record was adjusted using surrogate stream gage data to modify and estimate a longer streamflow record. The 1974 – 1978 Mill River flow duration curves were adjusted to a 52 year average by multiplying the stream flows by adjustment factors calculated for USGS gage 01196500 on the Quinnipiac River in Wallingford, CT. Monthly flow duration curves for the Quinnipiac River were developed for the 1974 – 1978 record and also for the 52 year record (1930 – 1982), and adjustment factors were calculated by comparing the short and long term records. These adjustment factors were then applied to the limited 1974 – 1978 Mill River Data to develop a 52-year average. Using the adjusted streamflow record, the 1984 analysis developed a flow duration curve and estimated the 25-percent exceedance flow to be approximately 92 cfs<sup>5</sup>. This estimate of the 25-percent exceedance flow is generally similar to the USGS gage 01196620 flow duration and StreamStats' estimates and substantially less than that included in the 2017 analysis, and the methodology used is appropriate, in GZA's opinion.

<sup>3</sup>U.S. Army Corps of Engineers, HEC-RAS River Analysis System, Hydraulic Reference Manual, Version 5.0, February 2016

<sup>4</sup> Roald Haestad, Lake Whitney Dam Hydroelectric Power Generation Feasibility Study, March 8, 1984

<sup>5</sup> The 25-percent exceedance flow was estimated as 84 cfs from the Haestad flow duration curve, however an additional 8 cfs is required to account for the draft intake flow to the water treatment plant.



A summary of estimated flows at the Lake Whitney Dam developed using the GZA, HDR and Haestad methodologies is summarized in Table 1 below.

**Table 1: Estimated Streamflow at Lake Whitney Dam**

Flow Estimate Type	Source	Estimated Flow (cfs)	
		25% Exceedance	50% Exceedance
Flow Duration Scaled to Site USGS 01196620 Mill River A (1968 – 2019)	GZA, 2019	86	45
Flow Duration at Site USGS 01196626 Mill River B (October 1974 to September 1978)	GZA, 2019	106	66
Annual Flow Duration at Site StreamStats Regional Regression Estimate	GZA, 2019	94	N/A
Flow Duration at Site Water Level Data and Rating Table (2000 – 2015)	GZA, 2019	170	109
Flow Duration at Site Water Level Data and Rating Table (2000 – 2015)	HDR, 2017	190	120
Flow Duration USGS 01196620 Mill River B (1974 – 1978) Surrogate based on USGS 01196500 Quinnipiac River (1930 – 1982)	Roald Haestad, 1984	92	56

*Recommended Flow Duration Curve and Design Flow*

Based on GZA’s evaluation of the above described data, we developed a synthetic flow duration curve so as not to underestimate flows at the site. GZA developed the synthetic flow duration record by applying a factor of 1.16x to the long-term flow duration curve developed from USGS gage 01196620 to increase the 25-percent exceedance flow from 86 cfs to 100 cfs. GZA recommends a 25-percent exceedance flow equal to 100 cfs which is within the range of the estimates developed by GZA and Haestad for the dam. As previously noted, GZA’s believes that the 2017 HDR analysis overestimates the available flow due to multiple factors. The synthetic flow duration curve is presented in **Figure 2** and the tabular data is presented within Table 3 of Attachment B.

The stream flow available for hydropower use is less than the total inflow to Lake Whitney because some flow is required to be used for the water treatment withdrawal and for the artificial waterfall. Based on the treatment plant intake flow of 8 cfs (5 mgd) and an assumed flow of 5 cfs for the artificial waterfall, approximately 13 cfs should be subtracted from the total flow available for hydropower generation (i.e. 100 cfs – 13 cfs = 87 cfs) **As such, GZA selected a turbine design flow of 87 cfs for the feasibility analysis.**

OPTION 1 – TRADITIONAL HYDROPOWER – EVALAUTION OF AVAILABLE HEAD

The typical gross head available from Lake Whitney to the Mill River downstream, is defined as the difference between normal water surface elevation upstream of the dam and normal tailwater elevation downstream of the dam and proposed hydropower facility. The normal head upstream of the dam was assumed to be coincident with the spillway crest (approximately elevation 35.1 feet NAVD88). GZA estimated the tailwater elevation using the hydrologic and hydraulic model developed by GZA under our H&H analysis<sup>6</sup> task of our current contract. Based on our selected design flow of 87 cfs, equal to the 25-percent exceedance of available flow, and review of the model results and surveyed

<sup>6</sup> “Engineering Report, Hydrology and Hydraulics Analysis, Summary Report, Lake Whitney Dam”, GZA GeoEnvironmental Inc., November 2019.



downstream water surface elevation, GZA assumed a tailwater elevation of 3.0 feet. Assuming one and a half feet of head loss for the hydropower conveyance system (e.g. entrance losses, penstock friction, etc.) a conservative typical net head available for hydropower generation is approximately 30.6 feet. If a more detailed analysis is conducted, gross heads can be estimated for multiple flow rate intervals which will likely result in slightly higher net heads at low flows and reduced net heads under higher flow rates and flood conditions. However, for this analysis it was assumed the rise in tailwater is approximately equal to the rise in headwater for the design flow range.

GZA's estimate of net head available was similar to the value estimated by HDR and Haestad. HDR estimated the net available head to be 29.75 feet assuming 1 foot of head loss. Haestad estimated the net available head to be between 25 feet and 29 feet for the first alternative and between 28 feet and 30 feet for the second alternative.

#### OPTION 2 – CONDUIT POWER – EVALUATION OF FLOW AND HEAD

GZA also evaluated the flow and head potential for a potential “conduit” hydropower facility associated with the 36-inch diameter transmission main between the dam and the WTP. The design flow for the WTP is 23 cfs, however, according to RWA, flows exceeding 8 cfs require pumping. According to SCCRWA, the current WTP intake flow via the 36-inch main is 8 cfs and the WTP operates 5 days a week.

Based on preliminary review of the Lake Whitney normal pool elevation of 35.0 feet and the approximate ground elevation of the WTP of approximately 13.0 feet, there is the potential for a gross head of approximately 22 feet. In GZA's opinion, we conservatively assumed 5 feet of head loss throughout the entire conduit system. Our losses assumptions included approximately 1 foot to account for the head required for the WTP flow to be conveyed by gravity and 4 feet of minor head loss through the system. In our opinion, using 17 feet of net head available to assess the feasibility of the conduit hydropower system is appropriate. HDR concluded that development of conduit hydropower at the site was not economically viable, although supporting information was not provided. Haestad did not evaluate the development of conduit hydropower.

#### **ESTIMATED POWER AND ENERGY PRODUCTION**

##### OPTION 1 – TRADITIONAL HYDROPOWER

The proposed hydropower system has been preliminarily designed for a flow of 87 cfs, 30.6 feet of net head, and run-of-the-river operation. Run-of-the-river operation means that only naturally occurring river flow (minus water supply withdrawals and conservation flows) is used for hydropower generation and no reservoir storage is used for hydropower generation. The production estimate is based on the power equation and a conservatively-assumed an average total water-to-wire system efficiency of 82.5 percent, which is intended to account for variable turbine efficiencies, transformer losses, and limited regular outage time. Once a turbine/generator package is selected, a more detailed system efficiency curve can be developed. Power and energy production based on the design flow is estimated as follows. The power and energy production calculations are based on the flow duration curve and represent average annual potential, and actual generation can vary up or down on a year to year basis based on hydrologic conditions. Supporting calculations are included in Table 4 in Attachment B.



Power Equation:  $P = (Q * H * e) / 11.8$

Where:

- P = Power (kW)
- Q = Maximum Flow (cfs), 87
- H = Net Head (feet), 30.6 feet
- e = efficiency (assume 82.5%)

**Estimated Generation Capacity (peak): 186 kW**

**Estimated Annual Energy Production: 613 MWh/yr**

Note that these estimates are preliminary and should be refined at later design stages based on the specific characteristics of available turbines, such as maximum design flow, minimum operation flow, and the specific flow-efficiency curve for the unit. The estimated generation capacity and energy productions is substantially less (< 40%) than that estimated in the 2017 HDR Memo and up to 25% greater than that in the 1984 Roald Haestad Study.

OPTION 2 – CONDUIT HYDROPOWER

GZA also estimated power and energy consumption for the conduit hydropower facility. The current WTP’s design flow for the 36-inch raw water line is 8 cfs (5 mgd), and the water line operates 5 days a week. Assuming the design flow of 8 cfs (5 days a week) and a design head of approximately 17 feet, the conduit hydropower facility could have up to a maximum generating capacity of approximately 10 kW and 59 MWh/yr.

**EQUIPMENT AND FACILITIES EVALUATION**

OPTION 1 – TRADITIONAL HYDROPOWER

The proposed location of the traditional hydropower project is adjacent to the outlet of the 42-inch blowoff. A bifurcation near the downstream end of the blowoff would be constructed to divert flow to a new powerhouse. The existing blowoff tailrace would be reconfigured to accommodate installation of the hydropower equipment. A new powerhouse would be constructed adjacent to the right tailrace training wall near the outlet of the blowoff. The new powerhouse could have an exterior appearance architecturally similar to the historic aesthetics at the site. As initially envisioned, the powerhouse would likely consist of three levels, depending on the kind of turbine selected. The turbine would be located on the turbine level with the draft tube below. The generator (for a vertical unit), hydraulic power unit, switch gear, protection, and ancillary systems would be located on the middle level (above the turbine level). Controls and electrical meter would be located on the third level at grade.

The net head available of 30.6 feet and the 25-percent duration available design flow of 87 cfs were compared with the optimal head ranges and flow ranges for each of the turbines as shown in **Figure 3**. Based on the available head and flow at the Lake Whitney Dam, the most favorable options for the type of turbine are judged to be Kaplan and crossflow turbines. The specific type of turbine selected for installation will be specified at a subsequent design stage of the project should the project proceed.

OPTION 2 – CONDUIT HYDROPOWER

The proposed location of the conduit hydropower project would be near the SCCRWA water treatment plant. Based on a historic survey drawing<sup>7</sup>, it appears that the 36-inch raw water line crosses under Whitney Avenue near the intersection

---

<sup>7</sup> “Exhibit A, Eli Whitney Museum, Inc, Hamden, Connecticut” Surveyed by Robert G. Snell, May 2, 1978



with Armory Street, and traverses Armory Street, and enters the water treatment plant along the east side of the building. The project could be located between the water treatment plant and Armory Street. The exact location of the project would be determined after additional utility information is provided. Given the proximity to the WTP it is recommended that a site assessment be performed to identify potential contaminants that could be encountered. The powerhouse would be a concrete vault either subsurface or below grade. The turbine would be installed along a bypass line to the 36-inch raw water line.

Based on the net head available of 17 feet and the design flow of 8 cfs most favorable options for the type of turbine as shown in **Figure 3** are judged to be low head and Kaplan. The specific type of turbine selected for installation will be specified at a subsequent design stage of the project should the project proceed.

### ALTERNATIVE TECHNOLOGIES

Turbulent<sup>8</sup> Turbines™ are a brand of vortex turbines designed for low head applications (5 feet to 16 feet). The design of the turbine is such that flow conveyed as a low-pressure vortex. Three models appear to be currently available, with a maximum design head of 13 feet. Two sequenced turbines can be used for head differentials of up to 16 feet. As previously discussed, the gross head available at the site is approximately 30.6 feet, therefore, it appears that these turbines are not suitable for the site.

Archimedes screw turbines are designed for low head (3 feet to 33 feet) and low flow (3 cfs to 530 cfs) applications. The rotor is housed within an inclined trough. The installation of an Archimedes screw turbine would involve modifications to the downstream face of the dam with substantial aesthetic impacts. Due to the historical importance of the site, and historical requirements to limited substantial changes to the site's aesthetics, consideration of the required modifications an Archimedes screw turbine was not considered feasible.

### **CONCEPTUAL ESTIMATE OF FINANCIAL FEASIBILITY**

GZA prepared a preliminary cost estimate for the major work items judged necessary to construct the proposed hydroelectric project as proposed above. Preliminary estimated cost data is shown in the Table below. The equipment costs used were conservatively selected based on similar projects. If the SCCRWA elects to pursue a more refined hydropower feasibility evaluation, a site-specific cost estimate could be developed with based on the specific characteristics of available turbines. Selection of site-specific equipment would refine the cost estimates and energy production, and it would be recommended that the energy production estimates be updated based on specific turbine equipment models should the project proceed. It should be noted that based on our experience on similar project where the calculations are updated based on site specific turbine models, there is no guarantee that it will increase the energy production estimates. Engineering and permitting cost estimates attempt to capture expected cost of obtaining FERC project approval but permitting costs may vary based on the extent of studies and investigation required by FERC and the magnitude of stakeholder involvement.

Through the FERC process, stakeholders (such as Historic Commission, US Fish and Wildlife, etc.) are invited to comment on the project and may request that studies be performed. Dam rehabilitation costs were not considered as part of the financial feasibility evaluation, but there could be cost synergies of completing the rehabilitation and hydropower development at the same time. Additionally, the construction costs were considered independent on the rehabilitation costs, and if the projects were to be completed at the same time, there would likely be cost synergies resulting in a lower

---

<sup>8</sup> <https://www.turbulent.be/>



cost. However, given the proposed timing for rehabilitation to occur in 2021 and the length of time necessary to complete FERC licensing, it is unlikely the hydropower construction could be completed in 2021.

GZA prepared the cost opinions using guidance similar to an Association for the Advancement of Cost Engineering (AACE) Class 4 construction cost opinion for the preferred alternative developed in this Feasibility Study. Listed below are the basic definitions of an AACE Class 4 cost opinion:

- **Level of Project Definition:** Between 1 and 15 percent complete.
- **End Usage:** Study, Pre-feasibility.
- **Expected Accuracy Range:** Low = -15 percent; High = +20 percent.
- **Definition of Estimate:** Class 4 estimates are generally prepared to form the basis for whether a project is feasible or not. As such, they typically form the initial control estimate against which further detailed study and/or design will occur. Typically, engineering is from 1 to 15 percent complete, and would comprise at a minimum the following: concept layout drawings, electrical one-lines, preliminary engineered process and utility equipment lists, economic evaluation, identified risks, and areas for further detailed study to serve as the basis for detailed design.

OPTION 1 – TRADITIONAL HYDROPOWER COST ESTIMATE

The conceptual cost estimate for Option 1 - Traditional Hydropower is provided in **Table 2A**.

Description	Cost
Contractor Mobilization/ Demobilization	\$60,000
Water Control for Construction and General Sediment Control	\$120,000
Reconfiguration of Tailrace	\$120,000
Bifurcation & Valves	\$300,000
Interconnection and Electric Lines to End User	\$220,000
Powerhouse and Utilities	\$960,000
Turbine, Generator, Electrical Equipment	\$840,000
Installation of Turbine, Generator, and Electrical Equipment	\$90,000
Oversight of Equipment Installation & Startup	\$60,000
<b>TOTAL COST OF STRUCTURES AND EQUIPMENT</b>	<b>\$2,770,000</b>
Permitting and FERC Compliance	\$420,000
Engineering Design, Studies and Field Engineering	\$600,000
Legal	\$60,000
Project Management	\$60,000
<b>TOTAL ESTIMATED ENGINEERING, LEGAL, AND PERMITTING COST</b>	<b>\$1,140,000</b>
<b>TOTAL ESTIMATED PROJECT COST</b>	<b>\$3,910,000</b>

**Table 2A: Option 1 – Traditional Hydropower - Conceptual Cost Estimate**

The total estimated cost to construct and commission the project is the sum of capital costs, engineering, permitting, and their contingencies. The total estimated cost for the proposed project is \$3,910,000, and the range of estimates for total



project cost are \$3,324,000 (-15% estimate) to \$4,692,000 (+20% estimate). This cost estimate range includes a contingency as defined by the range.

In addition to initial engineering and construction capital costs, the proposed hydropower project will require annual operations and maintenance (O&M) efforts. Total annual O&M costs are estimated to be approximately \$35,000 per year. This assumes approximately \$15,000 for a maintenance/operator contract, \$10,000 in a maintenance fund, and \$10,000 in a repair fund/ compliance fund. This assumes that the SCCRWA engages a subcontractor to perform general operations and maintenance of the project. Please note that costs associated with transferring energy across Whitney Avenue have not been included in the cost estimate.

OPTION 2 – CONDUIT HYDROPOWER CONCEPTUAL COST ESTIMATE

GZA also estimated the cost to develop conduit hydropower near the WTP. The total estimated cost to construct and commission the project is the sum of capital costs, engineering, permitting, and their contingencies. Licensing and permitting efforts for a conduit hydropower project would be significantly less than that of a traditional project. The total estimated cost for the proposed project is \$830,000, and the range of estimates for total project cost are \$706,000 to \$924,000 as shown in **Table 2B**.

<b>Description</b>	<b>Cost</b>
Project Materials and Civil Construction	\$300,000
Hydroelectric Generating Equipment	\$180,000
Electrical/Mechanical Installation and Commissioning	\$200,000
<b>TOTAL COST OF STRUCTURES AND EQUIPMENT</b>	<b>\$680,000</b>
Permitting and FERC Compliance	\$60,000
Engineering Design	\$90,000
<b>TOTAL ESTIMATED ENGINEERING, LEGAL, AND PERMITTING COST</b>	<b>\$150,000</b>
<b>TOTAL ESTIMATED PROJECT COST</b>	<b>\$830,000</b>

**Table 2B: Option 2 - Estimated Costs to Implement Conduit Hydropower at Lake Whitney Dam**

Additionally, annual operations and maintenance (O&M) efforts for a conduit project would be less than that of a traditional project, and total annual O&M costs are estimated to be approximately \$10,000 per year.

PROJECT REVENUE / AVOIDED COST FOR HYDROPOWER PRODUCTION

Development of hydropower at the Lake Whitney Dam could benefit the SCCRWA by way of avoided costs of electrical power. GZA (as did HDR and Haestad) assumed that all power generated by the project would be used at the SCCRWA WTP. However, we believe that transferring the energy across Whitney Avenue to the WTP will likely be an issue with utility provider property rights and this should be further investigated if the hydropower evaluation design advances. Please note that costs associated with transferring energy across Whitney Avenue have not been included in the cost estimate for Option 1. It is our experience based on similar projects that meetings with the public utility providers must be held to determine the technical and economic feasibility of transferring energy across public rights-of-way, and in some instances can be economically infeasible. This technical challenge is significant for the traditional hydropower option, and if SCCRWA elects to pursue this option, GZA recommends coordinating meetings with the utility provider to discuss the feasibility and challenges. These meetings are currently out of the scope of this analysis, and additional costs for this





process have been included within the economic analysis to account for the additional uncertainty and risk. Additionally, this specific technical challenge would not occur for the conduit hydropower scenario if the conduit unit were to be installed on the WTP property, across the public right-of-way.

Power generated at a hydropower project could be sold to the electrical distribution company, but this would require developing power purchase agreements. Given the feasibility level of this evaluation, our economic analysis is considered to be “simplified” as it does not account for the changing price of energy.

The value of the electrical power produced by the proposed project is a function of: 1) The price which would otherwise be paid for the supply and transmission of electricity from an outside commercial utility (for avoided use); 2) the wholesale value sold back into the grid (for power not instantaneously consumed on site at the WTP); and/or 3) the generation potential based on the hydrologic conditions for a given year. The value of electricity used to compute project benefits from avoided cost was estimated based upon experience with recent electricity rates paid by businesses with and without long term electricity contracts.

The value could be refined during the design phase if SCCRWA provided GZA with the actual rates paid by the SCCRWA to its electricity provider. For the purpose of this evaluation, GZA assumed that the SCCRWA, as the Owner of the Project, will reduce its energy cost equal to price the SCCRWA pays to its utility provider for electricity per kilowatt-hour, minus certain ineligible portions of the charge. Similar to the approach taken by HDR in their 2017 evaluation, GZA preliminarily assumed the overall value of the energy produced to be \$0.14/kWh, which is within the recent historical range of \$0.10 to \$0.20. As indicated previously, a detailed analysis of SCCRWA’s energy bills could be performed during the design phase to refine the estimate value. Annual avoided energy costs are the principal component contributing to the annual value of the energy as it is assumed that all of the power generated by the project will be consumed “behind the meter” at the SCCRWA’s WTP. As mentioned, the feasibility for transmission of power across Whitney Avenue should be further evaluated. Transmission across a public right of way would not be a concern for the conduit system. The estimated annual avoided energy costs are the product of the total cost of energy per kilowatt hour and the amount consumed onsite, as shown in Table below (assuming an electricity cost of \$0.14/ kWh). Constant energy production and prices are assumed, and the following Table summarizes the total value to SCCRWA of expected energy production during the first year of operation.

Renewable energy certificates (RECs) represent the environmental attributes of the power produced from renewable energy projects and are sold separate from commodity electricity. GZA researched the value of hydropower RECs in Connecticut. The Alternative Compliance Payment Rates for the 2018 compliance year is \$55.00 per MWh for Connecticut Renewable Energy Portfolio (RPS) Standard Class I<sup>9</sup>. However, we believe it is unlikely that the SCCRWA will be able to get the full value. We have assumed that the RECs will be worth approximately \$0.04/kWh.

The total annual benefits of the project are the sum of the value of energy produced (offset purchases), income from sale back into the grid (assumed to be zero), and the value of the Renewable Energy Credits minus annual operation and maintenance expenses. The Table below summarizes the total value to SCCRWA of expected energy production during the first year of operation based on typical river flows.

---

<sup>9</sup> Source: <https://programs.dsireusa.org/system/program/detail/195>



Average Annual Energy Production (kWh)	613,000
Est. Annual Avoided Energy Costs (@ \$0.14/kWh)	\$85,820
Est. Annual Income from Renewable Energy Credits (\$0.04/kWh)	\$24,520
Est. Annual Operations & Maintenance Expenses and Fees for Consultant FERC Filings	(\$35,000)
<b>Est. Total Annual Value of Energy Production - Annual</b>	<b>\$75,340</b>

**Table 3A: Option 1 – Traditional Hydropower - Estimated Annual Value of Avoided Cost**

Average Annual Energy Production (kWh)	59,000
Est. Annual Avoided Energy Costs (@ \$0.14/kWh)	\$8,260
Est. Annual Income from Renewable Energy Credits (\$0.04/kWh)	\$2,360
Est. Annual Operations & Maintenance Expenses and Fees for Consultant FERC Filings	(\$10,000)
<b>Est. Total Annual Value of Energy Production - Annual</b>	<b>\$620</b>

**Table 3B: Option 2 – Conduit Hydropower Estimated Annual Value of Avoided Cost**

SIMPLE PAYBACK ANALYSIS

GZA developed a simplified payback analysis as part of this preliminary hydropower resource assessment to demonstrate the potential of the Lake Whitney Dam site for hydropower generation. The simple payback analysis does not consider loan amounts, interest rates, etc. It is simply the preliminary estimate of project initial costs balanced by the amount of power generated and used on-site, converted to dollars. GZA recommends a more thorough pro-forma analysis in a future phase of study. The simple payback analysis is summarized below. The results of the simple analysis indicate the project is preliminarily estimated to pay for itself in about 52 years. The range of payback periods is 42 years to 65 years depending on the assumptions for the price of energy (\$0.10 to \$0.20) and the range of total project cost estimates.

	Min	Mean	Max
Estimated Total Development Costs:	\$3,324,000	\$3,910,000	\$4,692,000
Estimated Annual Value of Energy Produced:	\$50,820	\$75,340	\$112,120
Simple Payback Period:	65 years	52 years	42 years

**Table 4A: Option 1 – Traditional Hydropower - Simple Payback Analysis**

The payback periods presented in HDR’s analysis ranged from 11.2 years to 13.3 years depending on the option. Total costs ranged from \$3,000,000 to \$4,100,000 and the annual revenue estimates ranged from \$267,542 to \$308,515. HDR does not appear to include the estimated cost of permitting (\$250,000) as it is not a line item in the cost estimate tables. The difference in payback period is mostly dependent on the overestimate of the revenue potential, in GZA’s opinion. The payback periods outlined in the Haestad Report ranged from 20 to 30 years (based on Bond Issue).

Similarly, GZA performed a simple payback analysis for the conduit system. Based on the limited annual value of energy produced the project may not be profitable (i.e., annual expenses surpass annual value of energy). The mean payback period exceeds 100 years, and the range of payback periods is shown in the following table. The payback period is highly sensitive to the operation and maintenance costs of the system. GZA assumed a reduced cost for O&M and fees for



consultant FERC filings than for the traditional system, however, these assumptions can be modified based on the SCCRWA’s experience with conduit hydropower project at another facility.

	Min	Mean	Max
Estimated Total Development Costs:	\$706,000	\$830,000	\$996,000
Estimated Annual Value of Energy Produced:	-\$1,740	\$620	\$4,160
Simple Payback Period:	N/A	> 100 years	> 100 years

**Table 4B: Option 2 – Conduit Hydropower - Simple Payback Analysis**

**PERMITTING AND LICENSING CONSIDERATIONS**

FEDERAL ENERGY REGULATORY COMMISSIONS (FERC) CONSIDERATIONS AND PERMITTING

The proposed project meets the conditions requiring FERC approval in the form of a license or exemption; therefore, a FERC application must be filed. FERC issues three types of authorizations: 1) License, 2) 10-Megawatt (MW) Exemption and 3) Conduit Exemption. Filing for a FERC exemption provides some benefits over obtaining a 40-year license. An applicant for an exemption still must participate in the full initial licensing process but is thereafter exempt from re-licensing requirements in the future (i.e., in 40 years). There is minimally less documentation required for a 10-Megawatt exemption application as well. However, a project which is granted an exemption is subject to mandatory conditioning by Federal resource agencies.

Generally, the estimated time frame for FERC approval of a license is estimated to be between three to five years. The first step towards FERC Licensing would be to file a Preliminary Permit Application. By filing a Preliminary Permit application, SCCRWA will have first priority for developing the hydropower project (i.e., another project proponent would not have the ability to essentially take the rights to hydropower generation). Once the Preliminary Permit application is filed, SCCRWA should begin performing preliminary stakeholder consultations in order to obtain comments on the project. The next step is to file an application for a FERC license and to perform the environmental studies required to address the concerns of stakeholders with the ultimate goal of developing a project that is agreeable to all. Although unlikely, without a preliminary permit, other potential developers could file competing applications with FERC and thereby possibly gain priority for licensure at Lake Whitney Dam.

**OPTION 1 – TRADITIONAL HYDROPOWER**

To be eligible for a 10-Megawatt (MW) exemption, SCCRWA must have shoreline access easement for the entire shoreline of the defined project limits (i.e., the entire shoreline of Lake Whitney). At least one property has been identified along the shoreline that is not owned by SCCRWA, a parcel of land directly northeast of the dam is owned by the City of New Haven. A License will be needed unless sufficient prior shoreline property rights or easements can be affirmatively documented.

Once a FERC approval (license or exemption) is granted, the full project, including the dam falls under Federal jurisdiction. Dam safety and other aspects will thereafter be governed by FERC regulations and guidelines, including requirements for dam stability, spillway capacity, etc. Operating the dam and hydropower project under FERC jurisdiction will result in changes to the Owner’s responsibilities associated with the dam’s design criteria (e.g. seismic design methodology required by FERC is more rigorous than USACE) and inspection and reporting requirements (such as the requirement to complete Part 12 Inspections every 5 years, and FERC inspections annually). For the Lake Whitney Dam, the SDF is the



probable maximum flood (PMF) as confirmed by GZA's recent H&H Analysis<sup>10</sup>, and this is consistent with FERC requirements; thus, no change in the SDF would occur.

An additional consideration which will likely arise through FERC consultation will be the desire by stakeholder agencies to implement fish passage at Lake Whitney Dam. It has been reported that anadromous alewife have been documented within the plunge pool downstream of the Lake Whitney Dam, and it is likely that FERC could require both upstream and downstream fish passage if requested by project stakeholders such as US Fish and Wildlife or CT Bureau of Natural Resources Fisheries Division. Costs for construction of upstream fish passage at the dam could exceed \$200,000. It is noted that SCCWRA installed upstream eel passage located on the downstream right side of the spillway and Connecticut Department of Energy and Environmental Protection (DEEP) currently manages and performs minor maintenance of the passage. Downstream eel passage could become an additional consideration during FERC consultation because installation of a hydropower turbine has the potential to entrain eels. Fish passage requirements would add additional costs to the project and would have implications for water management at the reservoir (i.e. required discharges, etc.).

#### OPTION 2 – CONDUIT POWER

To be eligible for a conduit exemption the SCCRWA must use a conduit that was constructed for primarily non-hydropower purposes. Additionally, SCCRWA must own the land upon which the powerhouse would be located. Conduit projects that generate less than 5-MW are not subject to FERC jurisdiction. Therefore, construction of a conduit hydropower plant would not include fisheries related issues and would be substantially easier to license. Additionally, the conduit project could be installed near the WTP and eliminate the need to transmit energy across Whitney Ave.

#### ADDITIONAL FEDERAL, STATE AND LOCAL PERMITTING

In addition to FERC licensing, additional local, state and federal permits would likely be required. Costs for FERC licensing and local permitting are a not-inconsequential portion of the overall cost to implement hydropower at the site and were estimated by GZA to be approximately \$420,000. The following list contains the anticipated additional required permits for Option 1. Note Option 2 would likely require a subset of these permits. Many of these permits will be required to be obtained as part of the rehabilitation for Lake Whitney Dam and there is opportunity for synergies and cost reductions in local permitting if the hydropower project were to be permitted concurrently with the dam rehabilitation.

##### *Federal (non-FERC):*

- Section 404 dredge and fill permit: application filed with USACE
- Historic American Engineering Record (HAER): record files with National Park Service; Heritage Documentation Programs
  - Lake Whitney Dam is a registered American Water Landmark. Based on discussion with our subconsultant Public Archaeology Laboratory (PAL), further consultation with the State Historic Preservation Office (SHPO) will be required to determine if a HAER / Historic American Building (HAB) survey would be required to be completed as part of hydropower development at the site. A HAER survey was completed in January 2001 (HAER CT-186-C) and also in 1952. Based on these previous assessments, PAL does not expect that a new, full HAER documentation will be necessary for the alternatives being considered. However, if an adverse effect is found during future permitting efforts, the SHPO or other consulting party may propose some alternative form of mitigation during the consultation process.

---

<sup>10</sup> "Engineering Report, Hydrology and Hydraulics Analysis, Summary Report, Lake Whitney Dam", GZA GeoEnvironmental Inc., November 2019.



#### *State Permits:*

- Section 401 Water Quality Certification: application filed with CT DEEP; Inland Wetlands and Water Resources Division
- Section 106 State Historic Preservation Office: application filed with CT Historic Preservation Officer
- Dam Safety Repair and Alteration: approval of Filing Categories CP-016: application filed with CT DEEP
- NPDES Stormwater Diversion, Dewatering, Wastewater: application filed with CT DEEP, Stormwater
- Water Division: application filed with CT DEEP; Water Diversion Program
- Stream Channel Encroachment: application filed with CT DEEP; Inland Water Resources Division (Permit may not be required)
- Flood Management Certification: application filed with CT DEEP; Inland Water Resources Division
- Certificate of Environmental Compatibility and Public Need: application filed with Connecticut Siting Council
  - Pursuant to Connecticut General Statutes (CGS) § 16-50k new run-of-the river hydropower generation (customer- side distributed resource and grid-side distributed resource) with a nameplate capacity of 5 Megawatts (MW) or less requires the filing of a petition with the Connecticut Siting Council (CSC). CSC petition and review can be a time consuming and potentially costly process. The Connecticut Siting Councils' (Council) Generating Filing Requirement Guide<sup>11</sup> indicates that: A) facility owned and operated by a Private Power Producer (pursuant to C.G.S § 16-50i; defined in C.G.S. § 16-243b), B) where the owner is utilizing renewable energy sources with a generating capacity of 1 MW or less, and C) the owner is a qualifying small power production facility (16 U.S.C. § 796(17)(A)) the project is exempt from Council Jurisdiction. Based on this guidance, SCCRWA would meet these definitions and the project would be exempt from Council jurisdiction under all proposed hydropower options considered in our evaluation.
- Natural Diversity Data Base (NDDDB) Request for Review: form filed with CT DEEP
  - The project is located within an area of concern identified by the CT DEEP Natural Diversity Data Base (NDDDB), and thus will require CT DEEP NDDDB permitting. Related permitting costs could range between \$5,000 and \$10,000.

#### *Local Permits:*

- CT DEEP Inland Wetlands and Watercourses: application filed with Town of Hamden; Inland Wetlands Commission
- Local Historic District Commission: application filed with Hamden Historic Properties Commission
- Building Permits: application filed with Hamden Building Department
- Zoning Approval: application filed with Hamden Planning and Zoning Department

### **DAM REHABILITATION AND HYDROPOWER FUNDING**

GZA researched potential federal and state funding for dam reconstruction and installation of hydroelectric generation that could be applicable to the project. The Small Business Association's (SBA) 7(a) loan program could be used as a financing option. Interest rates are set by the lender although these rates are capped by the SBA. The SVA guarantees 75% for loans greater than \$150,000. The program offers low fees and interest rates and could offer another guaranteed loan

---

<sup>11</sup> <https://www.ct.gov/csc/cwp/view.asp?a=945&q=394942&cscPNavCtr=%7C>



option for the proposed facility. A summary of the rehabilitation funding opportunities and the hydropower installation opportunities are summarized as follows.

#### DAM REHABILITATION FUNDING

There are limited funding sources available at both the federal and state level for dam rehabilitation. In July 2019, GZA contacted the CT DEEP Dam Safety Section to inquire about potential dam rehabilitation funding. CT DEEP indicated that there was no available state funding for dam rehabilitation. The following funding sources for dam repair were identified by GZA:

- 1) The Federal Emergency Management Agency (FEMA) through the High Hazard Potential Dam Rehabilitation Grant (HHPD) Program provides grants for eligible high hazard potential dams. Non-profit entities are eligible for the grant. Additional eligibility requirements include:
  - a) located in a state with a state dam safety program;
  - b) classified as 'high hazard potential' by the dam safety agency;
  - c) has an emergency action plan approved by the state; and
  - d) the dam fails to meet minimum dam safety standards of the state; and the dam poses an unacceptable risk to the public as determined by the state.

The Lake Whitney dam meets the first three eligibility requirements for the HPPD Grant. However, according to the most recent dam inspection (May 1, 2018) of the Lake Whitney Dam the dam is in overall Fair condition. Given the current condition assessment of the dam, it seems unlikely CTDEEP Dam Safety program would determine that the Lake Whitney Dam fails to meet minimum dam safety standards or poses an unacceptable risk to the public. It should be noted that licensed hydroelectric dams are not eligible to receive funding through the HHPD program.

- 2) The Connecticut Flood and Erosion Control Board (FECB) program may be used to repair municipal owned dams. For the purposes of FECB funding tax districts are considered municipalities, however the dams may not be used for water supply. Therefore, the Lake Whitney Dam project is ineligible.
- 3) Loan funds to repair the dam may be available through the Connecticut Growth Fund. The loan may be use for the repairs as well as other related work including fees and expenses, engineering, and costs of preparing surveys, studies, site plans and specifications.

#### HYDROPOWER REVENUE INCENTIVES

There are limited funding sources available at both the federal and state level for hydropower installation. The following summarizes the finical incentives available to develop hydropower:

- 1) The CT Green Bank offers incentives and low-cost financing for renewable energy projects. The CT Green Bank use private-public partnerships to provide low-cost, long term financing by co-investing in renewable energy projects. Currently, the CT Green Bank has no programmatic mechanism to finance hydropower projects. However, the CT Green Bank has provided financing for three hydropower projects throughout the state through various means, but the funding was not granted until the design was complete. The CT Green Bank will not provide financing until the expected revenue of the project is well established and a Zero Emission Renewable Energy Credits (ZREC) contact has been procured. Financing through the CT Green Bank could be evaluated in future studies.



- 2) Current financial incentives to develop renewable energies in Connecticut include REC and Net Metering. However, Public Act 18-50 passed in May 2018, made significant changes in the Net Metering policies, REC compensation methodology and Renewable Portfolio Standard (RPS). This law ends Net Metering to new customers when the current ZRECs/Low Emission Renewable Energy Credits (LRECs) and Residential Solar Investment Programs (RISP) ends (likely 2020) or when the new compensation program is established. The act also increased the Class I requirements of the RPS (run-of-the river hydropower facilities are considered a Class I renewable energy source). However, in June 2019 H.B. 5002 was passed that will delay changes on net metering until after 2021.

Public Act 18-50 introduced three new programs:

- a) RSIP and Net Metering Successor (for residential customers);
- b) ZREC and Net Metering Successor (distributed energy projects for commercial/industrial and virtual Net Metering); and
- c) Shared Clean Energy Facility (SCEF) Program (for low-moderate income customers, small businesses, state or municipal or those unable to take advantage of the other two programs). DEEP recently submitted the proposed rules on this to CT Public Utilities Regulatory Authority (PURA) on July 11, 2019.

It is our understanding for a project to qualify for the ZREC and Net Metering Successor program a project would need to generate a minimum of 500kW. The estimated peak generating capacity of the traditional hydropower project is 153kW. Based on our understanding of the three programs introduced under Public Act 18-50 this project could qualify for the SCEF program, however it is unlikely to take advantage of the other two programs.

Projects eligible for the SCEF program will be selected through an annual competitive bid procurement for a total of six years. Renewable energy projects ranging from 100 to 4,000 kW are eligible. Projects can sell both energy and associated RECs. Projects will be compensated based on a tariff rate based on cents/kilowatt hour approved by PURA. This program is capped at 25 MW per year. The first solicitation is anticipated in 2020. Projects will be ineligible if it receives (or seeks to receive) Connecticut ratepayer funded incentives or grants or rebates from Connecticut Green Bank or the Conservation and Load Management Program. The estimated peak generating capacity of the conduit hydropower project is 10kW, which is less than the eligible energy production range for the SCEF program.

## SUMMARY AND RECOMMENDATIONS

Development of a hydroelectric project at the Lake Whitney Dam is technically feasible, although the payback periods for the traditional option is 42 to 65 years. The conduit option may not be profitable (i.e., annual expenses surpass annual value of energy), or the mean payback period exceeds 100 years, and was not considered economically feasible based on the current water withdrawal rates.

For Option 1 - Traditional hydropower project, a possible project configuration would be a new powerhouse constructed adjacent to the outlet of the 42-inch blowoff with a turbine connected to a by-pass from the existing 42-inch line. This proposed hydropower project has preliminarily been estimated to have the potential to generate 613,000 kWh during an average year, which is substantially less than that what HDR estimated in their 2017 hydropower assessment (i.e. 1,917,000 – 2,211,000 kWh). As we indicated earlier, we believe the reasoning for the overestimation of the 2017 assessment is a result of an overestimation of available flow and an excessive spillway weir coefficient. Our analysis assumes that all of the electricity can be used at the nearby WTP, and SCCRWA will benefit from the avoided cost of energy produced from the grid, and the sale of RECs. The total project cost estimates range from \$3.3M to \$4.7 M and the estimated annual revenue ranges from \$51k to \$112k depending on the price of energy, resulting in an estimated simple payback period ranging from 42 to 65 years without financial assistance.



For Option 2 – Conduit Hydropower Project has several other positive factors that are not available under Option 1 including simplified permitting and licensing process. Construction of the conduit powerhouse could be completed near the Water Treatment Plant and thus reduce complexity of crossing public roadway, and the rehabilitation project would not preclude construction in the future. Licensing for conduit hydropower installation is significantly less rigorous than that for traditional hydropower and will result in less cost. Additionally, there does not exist the risk for demands for inclusion of fish passage at the site for a conduit exemption. The total project cost estimates range from \$706k to \$996k and the estimated annual revenue ranges from \$-2k to \$4k depending on the price of energy. The conduit option may not be profitable (i.e., annual expenses surpass annual value of energy), or the mean payback period exceeds 100 years, and was not considered economically feasible based on the current water withdrawal rates. The Conduit Hydropower Project may be more economically feasible if additional flow to the WTP is utilized.

The addition of a hydropower project offers other benefits such as establishing SSCRWA's commitment to green energy and additional revenue streams. GZA understands that the SSCRWA considers a 15 year payback period reasonable. Based on the Authority's acceptable payback period implementation of hydropower is not likely viable given the current electricity markets and hydropower revenue incentives. SSCRWA may wish to reevaluate a hydropower project at the site if 1) changes to State or Federal regulations simplify permitting requirements, 2) changes to the current electricity market pricing, 3) new State or Federal hydropower revenue incentives, or 4) new grants or alternate revenue sources become available to reduce the financial cost of the project.

GZA appreciates the opportunity to continue to provide engineering services to South Central Connecticut Regional Water Authority. Please contact Mr. Todd Monson at (781) 278-5742 if you have any questions or concerns.

Very truly yours

**GZA GeoEnvironmental, Inc.**

Christine H. Stonier, P.E.  
Water Resource Engineer

Todd E. Monson, P.E.  
Senior Project Manager

Matthew A. Taylor P.E.  
Principal-in-Charge

Chad W. Cox, P.E. (MFA)  
Consultant/Reviewer

**Attachments**

Attachment A: Limitations

Attachment B: Supplemental Tables





## Figures



Figure 1: Flow Duration Curves for Mill River at Lake Whitney Dam

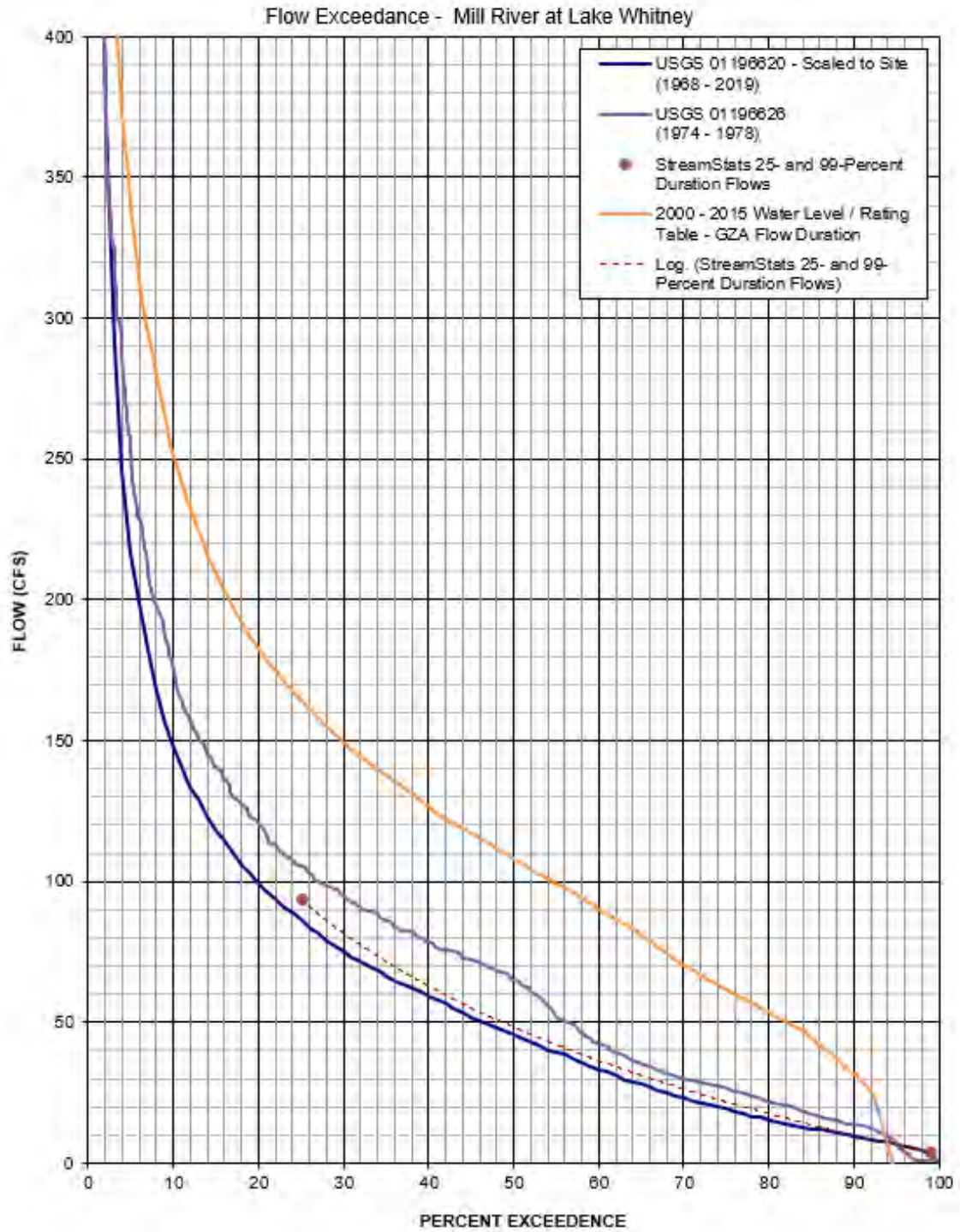



Figure 2: Design Flow Duration Curves for Mill River at Lake Whitney Dam

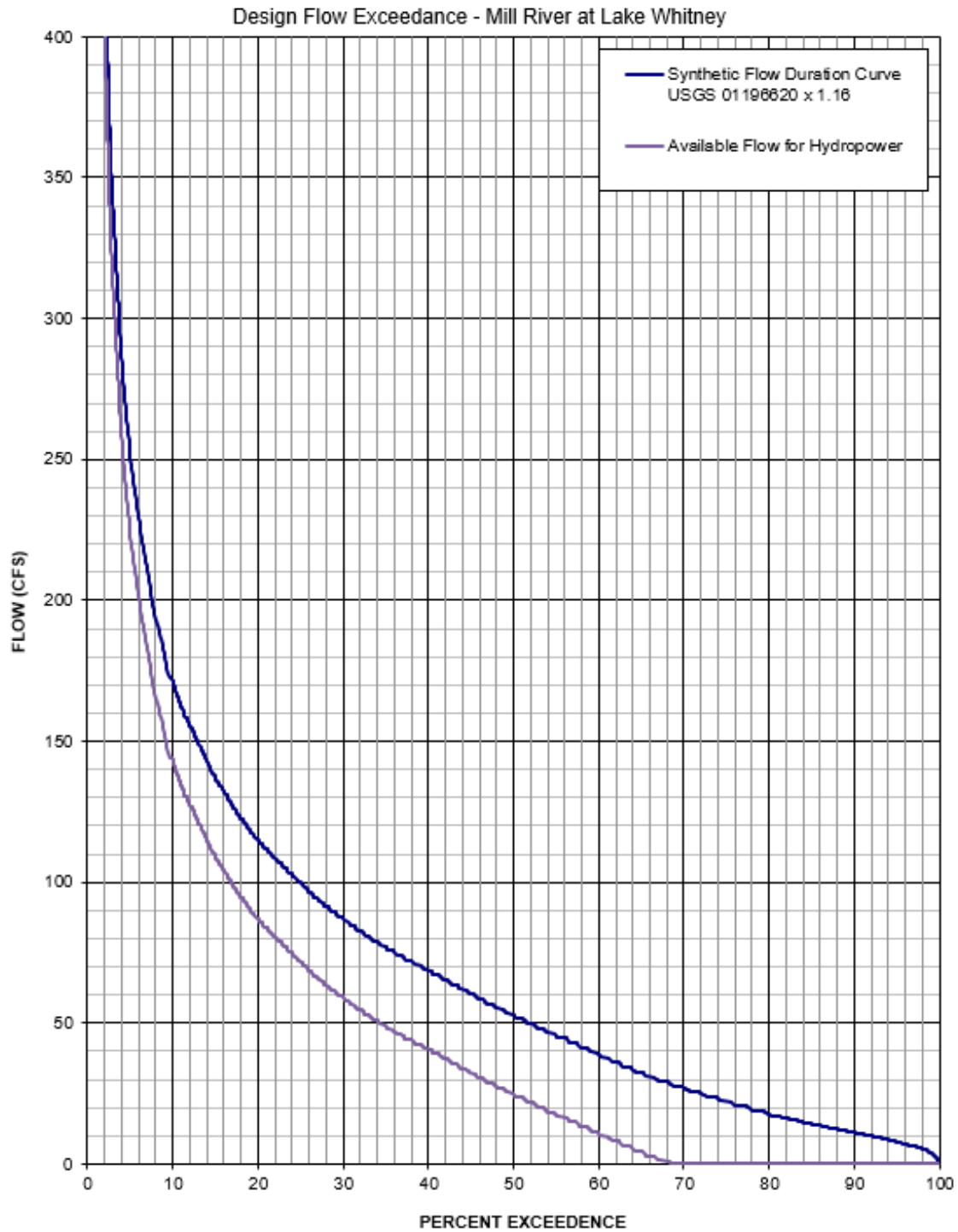
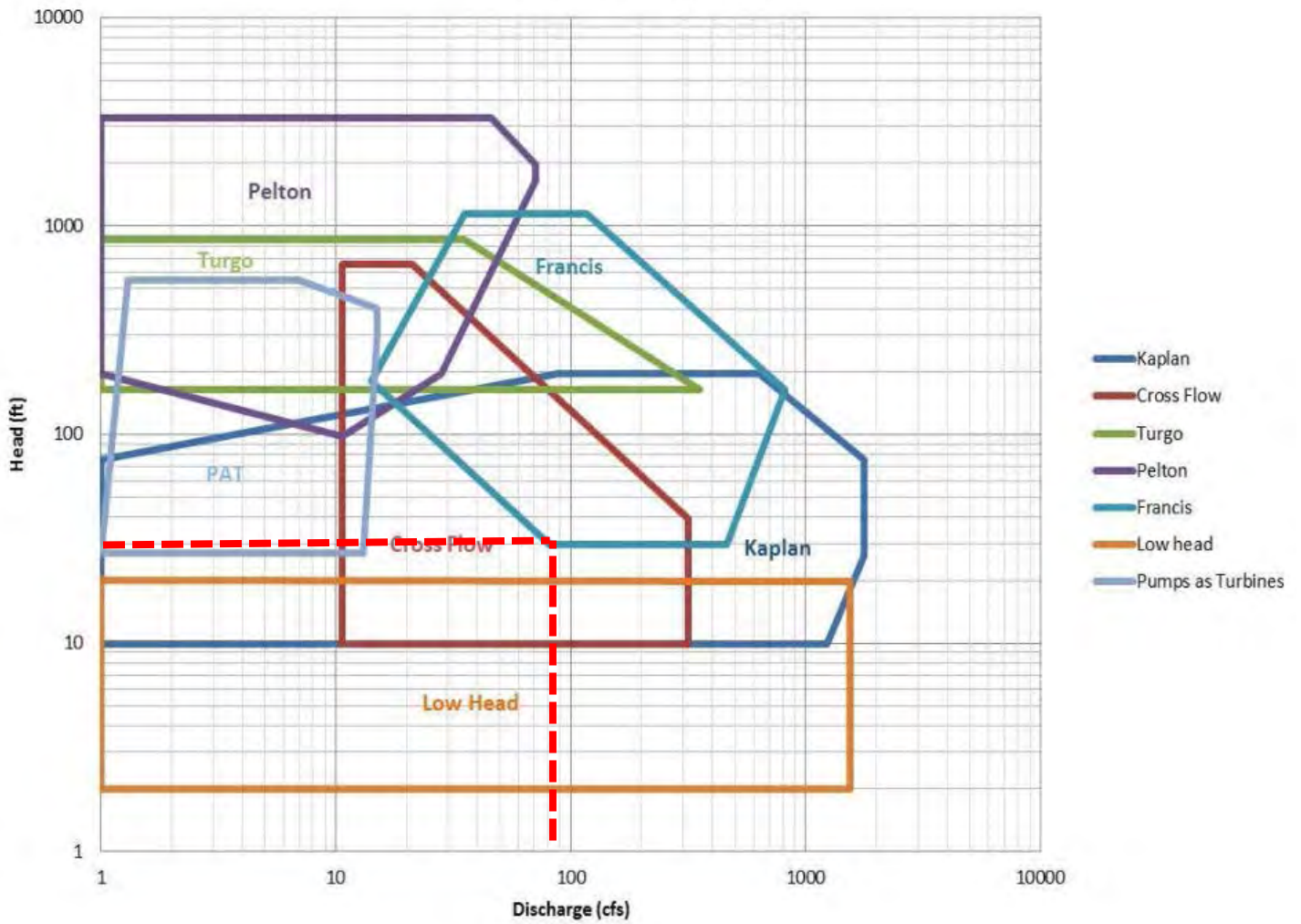

Figure 3: Various Turbine Operating Envelopes



# Turbine Selection





## **Attachment A – Limitations**



## **USE OF REPORT**

1. GeoEnvironmental, Inc. (GZA) prepared this report on behalf of, and for the exclusive use of by South Central Connecticut Regional Water Authority (SCCRWA / Client) for the stated purpose(s) and location(s) identified in the Report. Use of this report, in whole or in part, at other locations, or for other purposes, may lead to inappropriate conclusions; and we do not accept any responsibility for the consequences of such use(s). Further, reliance by any party not identified in the agreement, for any use, without our prior written permission, shall be at that party's sole risk, and without any liability to GZA.

## **GENERAL**

2. The observations described in this report were made under the conditions stated therein. The conclusions presented were based solely upon the services described therein, and not on scientific tasks or procedures beyond the scope of described services or the time and budgetary constraints imposed by the Client.
3. In preparing this report, GZA relied on certain information provided by the Client, state and local officials, and other parties referenced therein available to GZA at the time of the evaluation. GZA did not attempt to independently verify the accuracy or completeness of all information reviewed or received during the course of this evaluation.
4. Observations were made of the site and of structures on the site as indicated within the report. Where access to portions of the structure or site, or to structures on the site was unavailable or limited, GZA renders no opinion as to the condition of that portion of the site or structure. In particular, it is noted that water levels in the impoundment and elsewhere and/or flow over the spillway may have limited GZA's ability to make observations of underwater portions of the structure. Excessive vegetation, when present, also inhibits observations.
5. In reviewing this Report, it should be realized that the reported condition of the dam is based on observations of field conditions during the course of this study along with data made available to GZA. It is important to note that the condition of a dam depends on numerous and constantly changing internal and external conditions, and is evolutionary in nature. It would be incorrect to assume that the present condition of the dam will continue to represent the condition of the dam at some point in the future. Only through continued inspection and care can there be any chance that unsafe conditions be detected.

## **STANDARD OF CARE**

6. Our findings and conclusions are based on the work conducted as part of the Scope of Services set forth in the Report and/or proposal, and reflect our professional judgment. These findings and conclusions must be considered not as scientific or engineering certainties, but rather as our professional opinions concerning the limited data gathered during the course of our work. Conditions other than described in this report may be found at the subject location(s).
7. Our services were performed using the degree of skill and care ordinarily exercised by qualified professionals performing the same type of services at the same time, under similar conditions, at the same or a similar property. No warranty, expressed or implied, is made.
8. The interpretations and conclusions presented in the Report were based solely upon the services described therein, and not on scientific tasks or procedures beyond the scope of the described services. The work described in this report was carried out in accordance with the agreed upon Terms and Conditions of Engagement.

## **FLOOD EVALUATION**

9. GZA's flood evaluation was performed in accordance with generally accepted practices of qualified professionals performing the same type of services at the same time, under similar conditions, at the same or a similar property. No



warranty, expressed or implied, is made. The findings of the risk characterization are dependent on numerous assumptions and uncertainties inherent in the risk assessment process. The findings of the flood evaluation are not an absolute characterization of actual risks, but rather serve to highlight potential sources of risk at the site(s).

10. The study includes development of flood frequency curves. These curves were developed for the current climate and precipitation conditions. The development of flood-frequency curves relied on readably available historical storm data. Future storms that impact the project area may result in changes to the flood-frequency curves.
11. Unless specifically stated otherwise, the flood evaluations performed by GZA and associated results and conclusions are based upon evaluation of historic data, trends, references, and guidance with respect to the current climate and sea level conditions. Future climate change may result in alterations to inputs which influence flooding at the site (*e.g.* rainfall totals, storm intensities, mean sea level, *etc.*). Such changes may have implications on the estimated flood elevations, wave heights, flood frequencies and/or other parameters contained in this report.

### **SUBSURFACE CONDITIONS**

12. The sediment mapping and description, along with the conclusions and recommendations provided in our Report, are based in part on widely-spaced subsurface explorations by GZA and/or others, with a limited number of sediment samples and are intended only to convey trends in subsurface conditions. The boundaries between strata are approximate and idealized, and were based on our assessment of subsurface conditions. The composition of strata, and the transitions between strata, may be more variable and more complex than indicated. For more specific information on soil conditions at a specific location refer to the exploration logs. The nature and extent of variations between these explorations may not become evident until further exploration or construction. If variations or other latent conditions then appear evident, it will be necessary to reevaluate the conclusions and recommendations of this report.

### **COMPLIANCE WITH CODES AND REGULATIONS**

13. We used reasonable care in identifying and interpreting applicable codes and regulations. These codes and regulations are subject to various, and possibly contradictory, interpretations. Compliance with codes and regulations by other parties is beyond our control.
14. This scope of work does not include an assessment of the need for fences, gates, no-trespassing signs, repairs to existing fences and railings and other items which may be needed to minimize trespass and provide greater security for the facility and safety to the public. An evaluation of the project for compliance with OSHA rules and regulations is also excluded.

### **COST ESTIMATES**

15. Unless otherwise stated, our cost estimates are for comparative, or general planning purposes. These estimates may involve approximate quantity evaluations and may not be sufficiently accurate to develop construction bids, or to predict the actual cost of work addressed in this Report. Further, since we have no control over the labor and material costs required to plan and execute the anticipated work, our estimates were made using our experience and readily available information. Actual costs may vary over time and could be significantly more, or less, than stated in the Report.

### **ADDITIONAL INFORMATION**

16. In the event that the Client or others authorized to use this report obtain information on conditions at the site(s) not contained in this report, such information shall be brought to GZA's attention forthwith. GZA will evaluate such information and, on the basis of this evaluation, may modify the opinions stated in this report.



**ADDITIONAL SERVICES**

17. It is recommended that GZA be retained to provide services during any future: site observations, explorations, evaluations, design, implementation activities, construction and/or implementation of remedial measures recommended in this Report. This will allow us the opportunity to: i) observe conditions and compliance with our design concepts and opinions; ii) allow for changes in the event that conditions are other than anticipated; iii) provide modifications to our design; and iv) assess the consequences of changes in technologies and/or regulations.





## **Attachment B – Supplemental Tables**



**Table 1: 01196620 Mill River Flow Duration**

Duration	Scaled to Site Flow (cfs)	At Gage Flow (cfs)
99	3	2
95	6	5
90	8	7
85	11	8
80	13	10
75	17	13
70	20	16
65	24	19
60	29	23
55	34	26
50	39	31
45	45	35
40	51	40
35	57	45
30	65	51
25	75	58
20	86	67
15	102	80
10	128	99
5	188	146
1	464	361



**Table 2: Lake Whitney Flow Duration**

<b>Duration</b>	<b>Flow (cfs)</b>
99	1
95	7
90	14
85	18
80	22
75	27
70	30
65	36
60	43
55	52
50	66
45	73
40	79
35	87
30	95
25	106
20	121
15	141
10	177
5	253
1	466



**Table 3: 25-Percent Exceedance Flow at nearby Gages**

	<b>USGS 01196500 Quinnipiac River</b>	<b>USGS 01204000 Pomperaug</b>	<b>USGS 01189000 Pequabuck</b>
<b>25-Percent Exceedance (Mill River Gage Period of Record, 1968 - 2019)</b>	268	163	98
<b>25-Percent Exceedance (1974 – 1978)</b>	300	185	100
<b>Percent Difference</b>	+ 11%	+ 13%	+ 2%



**Table 4: Power and Energy Calculation**

Percentile	Total Flow (cfs)	Available Flow (cfs)	Turbine flow (cfs)	Head (ft)	Power (kW)	Energy (kW-hrs)
1	622	594	87	30.6	186	16,305
5	252	224	87	30.6	186	65,219
10	171	143	87	30.6	186	81,524
15	137	109	87	30.6	186	81,524
20	115	87	87	30.6	186	81,524
25	100	72	72	30.6	154	67,468
30	87	59	59	30.6	127	55,513
35	77	49	49	30.6	105	45,981
40	69	41	41	30.6	88	38,387
45	60	32	32	30.6	69	30,309
50	53	25	25	30.6	53	23,200
55	45	17	17	30.6	37	16,253
60	39	11	11	30.6	23	10,114
65	33	5	0	30.6	0	0
70	27	0	0	30.6	0	0
75	22	0	0	30.6	0	0
80	18	0	0	30.6	0	0
85	14	0	0	30.6	0	0
90	11	0	0	30.6	0	0
95	8	0	0	30.6	0	0
99	4	0	0	30.6	0	0
					Total (kWh)	613,000

**Fundamental Equations:**

$$P = (Q * H * e) / 11.8$$

$$E = (H * Q * e * t) / 11.8$$

Assumptions:

1. No conservation flow allowance currently assumed.
2. Preliminary design flow assumed to be 25-percent exceedance flow.
3. Preliminary design head based upon hydraulic height of dam minus an estimated 1.5 feet for head losses.
4. Efficiency assumed to be 82.5-percent.
5. Analysis assumes maximization of use of available flow through a single turbine without flow rate restrictions or significant minor losses. Actual system configuration may utilize multiple turbines and may have practical limitations.